

Why are smoke alarms necessary?

Most home fires occur between 11:00 P.M. and 6:00 A.M., when people are sleeping. Working smoke alarms detect fire in its early stages and provide your family with critical minutes necessary to reach safety. Deaths from home fires are more frequently due to smoke inhalation and toxic fumes than from burns. Early warnings save lives! Wisconsin fire deaths have been reduced by more than 42% since 1987 (when Wisconsin began requiring smoke alarms in older homes.) Unfortunately, about 30% of home fires start in rooms without working smoke alarms.

Wisconsin law requires homes to be protected by smoke alarms or a smoke detection system.

Owners must install and maintain the smoke alarms, and tenants must inform owners of any smoke alarm problems.

All smoke alarms used in Wisconsin must be Underwriters Laboratories (UL) listed, or equivalent, and must be either of the ionization or photo-electric types. (Heat detectors, which respond slower, may only be used in addition to smoke alarms.)

Ionization alarms respond to quick burning fires such as from wood or paper. The alarm sounds when the sensor becomes blocked by smoke particles.

Photoelectric alarms respond to slow burning fire such as upholstery or bedding. The alarm sounds when smoke particles break a light beam. Photoelectric alarms are less likely to sound a false alarm.

What kind of smoke alarm is required in your home?

It depends on when the permit to build your home was issued. Local ordinances may require additional features. In homes permitted prior to April 1, 1992, you may use self-contained battery-operated smoke alarms. For home permitted after April 1, 1992, refer to the table on the back of this brochure.

It is *recommended* that:

- All smoke alarms in your home be interconnected [if one activates they all sound together] and powered by both a building circuit and batteries to ensure they operate properly in all situations.

- Smoke alarms should be connected to a regular lighting circuit, but not on a switch, so the loss of power to the alarm is noticed because the lights are not working.

Where must smoke alarms be installed?

For one- and 2-family dwellings built before December 1, 1994, owners must install at least one smoke alarm on each floor level of each unit, including the basement.

It is *recommended* that:

- Alarms are placed between each sleeping area and the rest of the home, and above the base of any stairs on each floor level.

- Alarms are located in the hall outside the bedroom area and inside each bedroom.

- Bedroom doors should be kept closed when sleeping for additional protection.

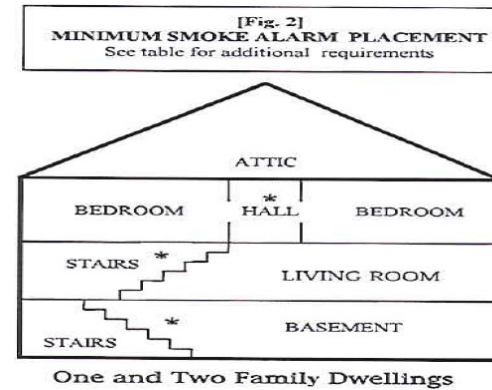

How should smoke alarms be installed?

All smoke alarms should be installed per the Manufacturer's instructions.

- Mount on the bottom of any exposed basement ceiling joists.

- Place at least 4 inches from the wall when installing on the ceiling. The center of the room is best.

- Place between 4 to 12 inches from the ceiling when installing on a wall. Be sure it is out of the dead air space where the ceiling and wall meet.

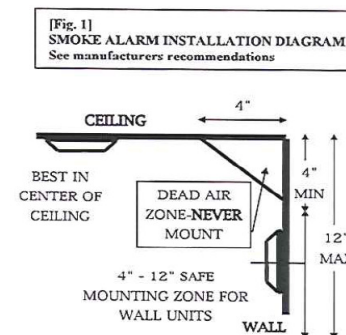

- Install within 3 feet of the highest part of a peaked or sloped ceiling.

- Place at least 3 feet away from any window, door or air register where drafts could prevent smoke from reaching the alarm.

- Mount away from kitchens where cooking could cause false alarms and subsequent disconnection.

- Do not install where there are extreme temperatures, excess humidity or heavy dust such as in bathrooms, unheated garages or attics.

It is recommended that tamper-resistant smoke alarms or smoke alarms wired to the building electrical system be installed if there is a problem with battery disconnection.

In older manufactured homes, mount smoke alarms only on interior walls and not on ceilings or exterior walls.

What maintenance is required?

Batteries - change at least once a year or more often if the low-battery warning activates. The National Fire Protection Association recommends that you change your battery twice a year at the same time that you change your clocks.

- Never "borrow" batteries from your smoke alarm to use in any other device.

- Photoelectric bulbs - change when the trouble indicator activates.

SMOKE DETECTORS SAVE LIVES AT HOME

A Brochure for One and Two Family
Dwellings



- Test your alarms monthly by using the test button or as required by the manufacturer. If it doesn't work, replace the battery. If it still doesn't work, replace the smoke alarm.
- Remove the cover and vacuum the alarm yearly to remove any sensor blocking dust particles.
- Replace all smoke alarms every 10 years or as recommended by the manufacturer. **NEW: September 1, 2011: Replacement of a smoke alarm that uses a battery as its primary power source shall be either hardwired or shall have a non-replaceable, non-removable battery that is capable of powering the alarm for at least 10 years.**
- Landlords must inform tenants in writing that they are responsible for informing their landlord in writing of any smoke alarm problems, such as a dead battery. The landlord has five days to correct the problem.

It is *recommended* that tamper-resistant smoke alarms, or preferably, building current powered smoke alarms be installed if there is a problem with battery removal or disconnection.

Tips to keep your family safe.

- Smoke alarms are not a replacement for fire prevention. Look at your property and your family's habits for sources of fires and eliminate them. A home safety checklist can be obtained from your local fire department.
- Be sure everyone in your household is familiar with the sound of the alarm.
- Plan and practice a fire escape drill with your family which includes at least two ways out of every room. Identify an outside meeting place where everyone will gather after the escape.

- Call the fire department immediately after you are safely out of the house.
- Keep matches and lighters out of children's reach and never leave candles unattended.
- Don't overload outlets or extension cords and replace or repair frayed electrical cords, sparking outlets or appliances.
- Clean fireplaces yearly and use metal or glass screens.
- Never smoke in bed, dispose of smoking materials in approved containers.
- Store flammable and combustible liquids away from heat sources and in their original containers.

**Remember, when the alarm sounds,
get out and stay out!**

Smoke and Carbon Monoxide Alarm Requirements	Battery-powered permitted	Building electrical system powered	Building power and battery backup	Interconnection between alarms	Alarms on every floor level	Alarms outside each sleeping area	Alarms in each bedroom
Date of building permit or construction							
Smoke alarms in one- and 2-family dwellings before 4-1-92	✓				✓		
Smoke alarms in Uniform Dwelling Code after 4-1-92		✓		✓	✓		
Smoke alarms in Uniform Dwelling Code after 12-1-95		✓		✓	✓	✓	
Smoke alarms in Uniform Dwelling Code after 4-1-01			✓	✓	✓	✓	✓
Carbon monoxide alarms before 2-1-11	✓*				✓		
Carbon monoxide alarms after 2-1-11		✓	✓	✓	✓	✓	

* Battery-powered or plug in.