

Wisconsin Administrative Code

Rules of INDUSTRY, LABOR AND HUMAN RELATIONS

MECHANICAL REFRIGERATION

Cite the rules in this Code as

(for example)

s. ILHR 45.01, Wis. Adm. Code

INDUSTRY, LABOR AND HUMAN RELATIONS

201 East Washington Ave.

Madison, Wisconsin 53702

608-266-3151



INTRODUCTION

Purpose and Structure

The legislature, by section 35.93 and chapter 227, Wis. Stats., directed the publication of the rules of administrative agencies having rule-making authority in a loose-leaf, continual revision system known as the WISCONSIN ADMINISTRATIVE CODE. The code is kept current by means of new and replacement pages. The pages are issued monthly, together with notices of hearings, notices of proposed rules, emergency rules, new rules, instructions for insertion of new material, and other information relating to administrative rules. This monthly service is called the WISCONSIN ADMINISTRATIVE REGISTER, and comes to the subscriber after the 25th of each month.

Availability

The complete code and the upkeep service are distributed to the county law libraries; to the libraries of the University of Wisconsin Law School and Marquette University Law School; to the State Historical Society; to the Legislative Reference Bureau and to the State Law Library, and to certain designated public libraries throughout the state.

The sale and distribution of the code and of its parts is handled by Department of Administration, Document Sales and Distribution, 202 S. Thornton Ave., Madison, Wisconsin 53702.

Table of Contents

Each code with more than one chapter will have a table of chapters. After the title of each chapter will be the page numbers on which the chapter begins. Each chapter will have a table of sections. When a chapter has more than 10 sections and is over 10 pages in length the page number which that particular section begins on will be inserted after the title of the section.

History Notes

Each page of the code as it was originally filed and printed pursuant to the 1955 legislation, is dated "1-2-56". A rule which is amended or created subsequent to the original printing date is followed by a history note indicating the date and number of the REGISTER in which it was published and the date on which the amendment or the rule became effective. The absence of a history note at the end of a section indicates that the rule has remained unchanged since the original printing in 1956. The date line at the bottom of the page indicates the month in which the page was released.

In some instances an *entire* chapter has been repealed and recreated subsequent to the original printing date. When this occurs a history note has been placed at the beginning of the chapter to contain this information. A separate history note appears after each section indicating the date when the revision became effective.

Index

The index for the complete Wisconsin Administrative Code will be found at the end of the last volume. It will be recompiled, reprinted and distributed annually. Some codes have a separate index prepared by the agency involved. See the Building Code for an example.

Chapter ILHR 45

MECHANICAL REFRIGERATION

ILHR 45.01	Scope (p. 1)	ILHR 45.16	Refrigerating system classification (p. 10)
ILHR 45.02	Purpose (p. 1)	ILHR 45.17	Refrigerant classification (p. 13)
ILHR 45.03	Application (p. 1)	ILHR 45.18	Requirements for institutional, public assembly, residential, and commercial occupancies (p. 13)
ILHR 45.04	Saving and severable clauses (p. 2)	ILHR 45.19	Requirements for industrial occupancies (p. 18)
ILHR 45.05	Definitions (p. 2)	ILHR 45.20	Design and construction of equipment (p. 19)
ILHR 45.06	Adoption of standards (p. 6)	ILHR 45.21	Pressure-limiting devices (p. 23)
ILHR 45.07	Installation registration (p. 6)	ILHR 45.22	Pressure-relief protection (p. 24)
ILHR 45.08	Inspections (p. 7)	ILHR 45.23	Installation requirements (p. 29)
ILHR 45.09	Implementation of rules (p. 8)	ILHR 45.24	Field tests (p. 32)
ILHR 45.10	Fees (p. 8)	ILHR 45.25	General requirements (p. 33)
ILHR 45.11	Enforcement (p. 8)		
ILHR 45.12	Appeals (p. 8)		
ILHR 45.13	Petition for modification (p. 8)		
ILHR 45.14	Penalties (p. 8)		
ILHR 45.15	Occupancy classification (p. 9)		

Note: Chapter Ind 45 as it existed on August 31, 1983 was repealed and a new chapter ILHR 45 was created effective September 1, 1983.

ILHR 45.01 Scope. The provisions of this chapter are intended to provide for the safe design, construction, installation, operation and inspection of every refrigerating system employing a fluid which normally is vaporized and liquefied in its refrigerating cycle, when employed under the occupancy classifications listed in s. ILHR 45.15. The provisions of this chapter do not apply to the use of water or air as a refrigerant, nor to gas bulk storage tanks that are not permanently connected to a refrigerating system, nor to refrigerating systems installed on railroad cars, motor vehicles, motor drawn vehicles or on shipboard.

History: Cr. Register, September, 1983, No. 333, eff. 10-1-83.

ILHR 45.02 Purpose. This chapter establishes minimum safeguards to life, health and property; defines certain practices which are inconsistent with safety; and prescribes standards of safety which will properly influence future progress and developments in refrigerating systems.

History: Cr. Register, September, 1983, No. 333, eff. 10-1-83.

ILHR 45.03 Application. (1) **SYSTEMS COVERED.** This chapter shall apply to refrigerating systems installed after its effective date and to modifications to existing systems.

(2) **LISTED EQUIPMENT.** Equipment listed by an approved nationally recognized testing laboratory is deemed to meet the design, manufacture and factory test requirements of this chapter, for the refrigerant or refrigerants for which such equipment is designed. Listed refrigerating systems are not required to be field tested to comply with s. ILHR 45.24.

History: Cr. Register, September, 1983, No. 333, eff. 10-1-83.

ILHR 45.04 Saving and severable clauses. If, for any reason, any one or more sections, sentences, clauses or parts of this chapter are held invalid, such invalidity shall not affect, impair or invalidate the remaining provisions.

History: Cr. Register, September, 1983, No. 333, eff. 10-1-83.

ILHR 45.05 Definitions. For the purpose of this chapter, the following definitions shall apply.

(1) "Absorber or adsorber" means that part of the low side of an absorption system used for absorbing or adsorbing vapor refrigerant.

(2) "Absorption or adsorption system" means a refrigerating system in which the gas evolved in the evaporator is taken up by an absorber or adsorber.

(3) "Approved" means acceptable to the department.

(4) "Approved nationally recognized testing laboratory" means one acceptable to the department, that provides uniform testing and examination procedures and standards for meeting the design, manufacture and factory test requirements of this chapter, is properly organized, equipped and qualified for testing, and has a follow-up inspection service of the current production of the listed products.

(5) "Brazed joint" means a gas-tight joint obtained by the joining of metal parts with alloys which melt at temperatures higher than 800° F., but less than the melting temperatures of the joined parts.

(6) "Brine" means any liquid, used for the transmission of heat without a change in its state, having no flash point or a flash point above 150° F.

(7) "Companion or block valves" means pairs of mating stop valves, valving off sections of systems and arranged so that these sections may be joined before opening these valves or separated after closing them.

(8) "Compressor" means a specific machine, with or without accessories, for compressing a given refrigerant vapor.

(9) "Compressor unit" means a compressor with its prime mover.

(10) "Condenser" means that part of the system designed to liquefy refrigerant vapor by removal of heat.

(11) "Condenser coil" means a condenser constructed of pipe or tubing other than a shell and tube or shell and coil type.

(12) "Condensing unit" means a specific refrigerating machine combination for a given refrigerant, consisting of one or more power-driven compressors, condensers, liquid receivers, and the regularly furnished accessories.

(13) "Container" means a cylinder for the transportation of refrigerant.

(14) "Critical pressure, critical temperature and critical volume" means the terms given to the state points of a substance at which liquid and vapor have identical properties. Above the critical pressure or criti-

cal temperature there is no line of demarcation between liquid and gaseous phases.

(15) "Department" means the department of industry, labor and human relations.

(16) "Department store" means the entire space occupied by one tenant or more than one tenant in an individual store where more than 100 persons commonly assemble on other than the street-level floor for the purpose of buying personal wearables and other merchandise.

(17) "Design pressure" means the maximum allowable working pressure for which a specific part of a system is designed.

(18) "Duct" means a tube or conduit used for conveying or encasing purposes as specifically defined as follows:

(a) "Air duct" means a tube or conduit used for conveying air. The air passages of self-contained systems are not to be construed as air ducts.

(b) "Pipe duct" means a tube or conduit used for encasing pipe.

(c) "Wire duct" means a tube or conduit used for encasing either moving or stationary wire, rope or similar materials.

(19) "Entrance" means a confined passageway immediately adjacent to the door through which people enter a building.

(20) "Evaporator" means that part of the system designed to vaporize liquid refrigerant to produce a refrigeration effect.

(21) "Evaporator coil" means an evaporator constructed of pipe or tubing other than a shell and tube or shell and coil type.

(22) "Exit" means a confined passageway immediately adjacent to the door through which people leave a building.

(23) "Field test" means a test performed in the field to prove system tightness.

(24) "Fusible plug" means a device having a predetermined temperature-fusible member for the relief of pressure.

(25) "Generator" means a device equipped with a means of heating used in an absorption system to drive refrigerant out of solution.

(26) "Hallway" means a corridor for the passage of people.

(27) "High side" means the parts of a refrigerating system subjected to condenser pressure.

(28) "Humanly occupied space" means a space normally frequented or occupied by people but excluding machinery rooms and walk-in coolers used primarily for refrigerated storage.

(29) "Internal gross volume" means the volume as determined from internal dimensions of the container with no allowance for volume of internal parts.

(30) "Limited charge system" means a system in which, with the compressor idle, the internal volume and total refrigerant charge are such

that the design pressure will not be exceeded by complete evaporation of the refrigerant charge.

(31) "Listed" means equipment that has been tested and is identified as acceptable by an approved nationally recognized testing laboratory.

(32) "Liquid receiver" means a vessel permanently connected to a system by inlet and outlet pipes for storage of a liquid refrigerant.

(33) "Lobby" means a waiting room or large hallway serving as a waiting room.

(34) "Low side" means the parts of a refrigerating system subjected to evaporator pressure.

(35) "Machinery" means the refrigerating equipment forming a part of the refrigerating system including, but not limited to, any or all of the following: compressor, condenser, generator, absorber or adsorber, liquid receiver, connecting piping, or evaporator.

(36) "Machinery room" means a room in which a refrigerating system is permanently installed and operated but not including evaporators located in a cold storage room, refrigerator box, air cooled space or other enclosed space. Closets solely contained within, and opening only into, a room shall not be considered machinery rooms but shall be considered a part of the machinery room in which they are contained or into which they open. The space in which a self-contained system is located is not a machinery room.

(37) "Machinery room, class T" means a machinery room with specific restrictions and requirements. [See s. ILHR 45.23 (12) (e)]

(38) "Manufacturer" means the company or organization which evidences its responsibility by affixing its name or nationally registered trademark or trade name to the refrigeration equipment concerned.

(39) "Mechanical joint" means a gas-tight joint, obtained by the joining of metal parts through a positive-holding mechanical construction.

(40) "Nonpositive displacement compressor" means a compressor in which increase in vapor pressure is attained without changing the internal volume of the compression chamber.

(41) "Piping" means the pipe or tube mains for interconnecting the various parts of a refrigerating system. Piping includes, but is not limited to, pipe, flanges, bolting, gaskets, valves, fittings, the pressure containing parts of other components such as expansion joints, strainers, and devices which serve such purposes as mixing, separating, muffling, snubbing, distributing, metering or controlling flow, pipe supporting fixtures and structural attachments.

(42) "Positive displacement compressor" means a compressor in which increase in pressure is attained by changing the internal volume of the compression chamber.

(43) "Premises" means the buildings and that part of the grounds of one property, where an installation would affect the safety of those buildings or adjacent property, and the occupants thereof.

(44) "Pressure-imposing element" means any device or portion of the equipment used for the purpose of increasing the refrigerant vapor pressure.

(45) "Pressure-limiting device" means a pressure-responsive mechanism designed to automatically stop the operation of the pressure-imposing element at a predetermined pressure.

(46) "Pressure-relief device" means a pressure-actuated valve or rupture member designed to automatically relieve excessive pressure.

(47) "Pressure-relief valve" means a pressure-actuated valve held closed by a spring or other means and designed to automatically relieve pressure in excess of its setting.

(48) "Pressure vessel" means any refrigerant-containing receptacle of a refrigerating system other than evaporators, evaporator coils, compressors, condenser coils, controls, headers, pumps and piping. Each separate evaporator section containing less than 1/2 cubic foot of refrigerant volume is not considered a pressure vessel.

(49) "Psia" means pounds per square inch absolute.

(50) "Psig" means pounds per square inch gauge.

(51) "Refrigerant" means a substance used to produce refrigeration by its expansion or vaporization.

(52) "Refrigerating system" means a combination of interconnected refrigerant-containing parts constituting one closed refrigerant circuit in which a refrigerant is circulated for the purpose of extracting heat.

(53) "Rupture member" means a device that will rupture at a predetermined pressure.

(54) "Saturation pressure" means the pressure of a refrigerant at which there is stable coexistence of the vapor and liquid or the vapor and solid phase.

(55) "Sealed absorption system" means a unit system for Group 2 refrigerants only in which all refrigerant-containing parts are made permanently tight by welding or brazing against refrigerant loss.

(56) "Secondhand pressure vessel" means a pressure vessel that has changed both location and ownership subsequent to the original installation.

(57) "Self-contained system" means a complete factory-made and factory-tested system in a suitable frame or enclosure which is fabricated and shipped in one or more sections and in which no refrigerant-containing parts are connected in the field other than by companion or block valves.

(58) "Soldered joint" means a gas-tight joint obtained by the joining of metal parts with metallic mixtures or alloys which melt at temperatures between 400° F. and 800° F.

(59) "Stop valve" means a device to shut off the flow of refrigerant.

ILHR 45

(60) "Supervised alarm" means an alarm so arranged that upon any malfunction in the system an audible trouble signal will be actuated instantly.

(61) "Tenant" means a person, firm, or corporation possessed with the legal right to occupy premises.

(62) "Ultimate strength" means the highest stress level which the component can tolerate without rupture.

(63) "Unprotected tubing" means tubing which is not protected by enclosure or suitable location so that it is exposed to crushing, abrasion, puncture or similar mechanical damage under installed conditions.

(64) "Unit system" means a self-contained system which has been assembled and tested prior to its installation and which is installed without connecting any refrigerant-containing parts. A unit system may include factory-assembled companion or block valves.

(65) "Welded joint" means a gas-tight joint, obtained by the joining of metal parts in the plastic or molten state.

History: Cr. Register, September, 1983, No. 333, eff. 10-1-83.

ILHR 45.06 Adoption of standards. (1) **CONSENT TO INCORPORATE.** Pursuant to s. 227.025, Stats., the attorney general and the revisor of statutes have consented to the incorporation by reference of the following standards:

(a) American National Standards Institute, Inc., 1430 Broadway, New York, NY 10018, Refrigeration Piping, ANSI B31.5-1974 with B31.5a-1978 addenda.

(b) American Society for Testing and Materials, 1916 Race Street, Philadelphia, PA 19103, Specification for Seamless Copper Water Tube, ASTM B88-80; and Specification for Seamless Copper Tube for Air Conditioning and Refrigeration Field Service, ASTM B280-80.

(2) **INTERIM AMENDMENTS.** Interim amendments of the standards listed in sub. (1) will have no effect in the state until such time as this section is correspondingly revised to reflect those changes.

(3) **AVAILABILITY OF STANDARDS.** The standards may be obtained at a nominal cost by writing to the respective addresses listed in sub. (1).

(4) **FILING OF STANDARDS.** Copies of the standards in reference are on file in the offices of the department, the secretary of state and the revisor of statutes.

History: Cr. Register, September, 1983, No. 333, eff. 10-1-83.

ILHR 45.07 Installation registration. (1) **CLASSIFICATIONS.** The installing contractor shall register with the department the installation of new, used or additional mechanical refrigeration systems of the following classifications:

(a) Any system or unit system using a Group 1 refrigerant and having a capacity rated at or greater than 100 horsepower, 100 tons or 100,000 volt-amperes.

Register, September, 1983, No. 333
Mechanical Refrigeration

(b) Any system or unit system using a Group 2 or Group 3 refrigerant and having a capacity rated at or greater than 10 horsepower, 10 tons or 10,000 volt-amperes.

(2) FORMS. Registration information shall be submitted on form DILHR SB-34 obtainable from the department.

Note: See Appendix for further information.

(3) SUBMITTAL. The registration form shall be submitted to the department before the system is placed in operation.

Note: The purpose of the registration is so that inspections can be made as specified in s. ILHR 45.08 (2).

(4) CERTIFICATE OF OPERATION. (a) The owner or user of a mechanical refrigeration system which requires periodic inspections under s. ILHR 45.08 (3) shall be responsible to obtain and maintain a valid certificate of operation.

(b) After each periodic inspection a certificate of operation shall be issued by the department upon determination that the system meets the applicable requirements of this chapter.

(c) The certificate of operation shall indicate the maximum allowable working pressure permitted under the requirements of this chapter.

(d) The certificate of operation shall be valid until the next required periodic inspection as specified in s. ILHR 45.08 (3).

(5) REACTIVATION. The owner or user shall notify the department before reactivating a mechanical refrigeration system at any time after the certificate of operation has expired.

History: Cr. Register, September, 1983, No. 333, eff. 10-1-83.

ILHR 45.08 Inspections. (1) GENERAL REQUIREMENTS. The authorized inspectors of the department, upon presenting appropriate credentials to the owner, operator or agent in charge, may:

(a) Enter without delay and at reasonable times any factory, plant, establishment, construction site or other area, workplace or environment where work is performed by an employe of an employer; and

(b) Inspect and investigate during regular working hours and at other reasonable times, and within reasonable limits and in a reasonable manner, any place of employment and all pertinent conditions, structures, machines, apparatus, devices, equipment and materials therein, and to question privately any employer, owner, operator, agent or employe.

Note: The department policy is not to give advance notice, but in the scheduling and in the act of inspecting it may not always be possible to avoid advance notice, but otherwise these rules will be diligently observed.

(2) INSTALLATION INSPECTION. (a) Mechanical refrigeration systems which require registration under s. ILHR 45.07 (1) shall be inspected by the department before the system is placed in operation.

(b) Refrigerant piping and welded joints erected on the premises for systems using a Group 2 or Group 3 refrigerant shall be inspected by the department prior to being covered or enclosed.

ILHR 45

(3) **PERIODIC INSPECTIONS.** Any mechanical refrigeration system or unit system using a Group 2 or Group 3 refrigerant and having a capacity rated at or greater than 10 horsepower, 10 tons or 10,000 volt-amperes shall be subject to inspection by the department at least once every 12 months.

History: Cr. Register, September, 1983, No. 333, eff. 10-1-83.

ILHR 45.09 Implementation of rules. Failure on the part of a superintendent, foreman, boss, or other person having control of any place of employment, employe or operation, to carry out any rule prescribed in this chapter is violation of the rule by the employer.

History: Cr. Register, September, 1983, No. 333, eff. 10-1-83.

ILHR 45.10 Fees. Fees for the registration of mechanical refrigeration systems, certificate of operation, inspections and petitions for modification shall be submitted as specified in ch. Ind 69.

History: Cr. Register, September, 1983, No. 333, eff. 10-1-83.

ILHR 45.11 Enforcement. The provisions of this chapter shall be enforced by the department.

History: Cr. Register, September, 1983, No. 333, eff. 10-1-83.

ILHR 45.12 Appeals. Any person affected by any local order which is in conflict with a rule of the department may petition the department for a hearing on the grounds that the local order is unreasonable or in conflict with the rule of the department or both.

Note: Section 101.01 (1) (g), Stats., defines "local order" as any ordinance, order, rule or determination of any common council, board of aldermen, board of trustees or the village board, of any village or city, or the board of health of any municipality, or an order or direction of any official of such municipality, upon any matter over which the department has jurisdiction.

History: Cr. Register, September, 1983, No. 333, eff. 10-1-83.

ILHR 45.13 Petition for modification. The department may consider and may grant modification to an administrative rule upon receipt of a fee and a completed petition for modification form (form SB-8) from the owner, provided an equivalency is established in the petition for modification which meets the intent of the rule being petitioned. The department may impose specific conditions in a petition for modification to promote the protection of the health, safety or welfare of the employes or the public. Violation of those conditions under which the petition for modification is granted constitutes a violation of this chapter.

Note: Copies of form SB-8 are available from the Division of Safety and Buildings, P.O. Box 7969, Madison, Wisconsin 53707.

History: Cr. Register, September, 1983, No. 333, eff. 10-1-83.

ILHR 45.14 Penalties. Penalties for violation shall be assessed in accordance with s. 101.02, Stats.

Note #1: Section 101.02 (13) (a), Stats., indicates penalties will be assessed against any employer, employe, owner or other person who fails or refuses to perform any duty lawfully enjoined, within the time prescribed by the department, for which no penalty has been specifically provided, or who fails, neglects or refuses to comply with any lawful order made by the department, or any judgment or decree made by any court in connection with ss. 101.01 to 101.25, Stats. For each such violation, failure or refusal, such employe, owner or other person

must forfeit and pay into the state treasury a sum not less than \$10 nor more than \$100 for each violation.

Note #2: Section 101.02 (12), Stats., indicates that every day during which any person, persons, corporation or any officer, agent or employe thereof, fails to observe and comply with an order of the department will constitute a separate and distinct violation of such order.

History: Cr. Register, September, 1983, No. 333, eff. 10-1-83.

ILHR 45.15 Occupancy classification. (1) GOVERNED LOCATIONS. Locations governed by this chapter in which refrigerating systems may be placed are grouped by occupancy as follows:

(a) Institutional occupancy, as used in this chapter, shall apply to that portion of the premises in which persons are confined to receive medical, charitable, educational, or other care or treatment, or in which persons are held or detained by reason of public or civic duty, including, but not limited to, hospitals, nursing homes, asylums, sanitariums, police stations, jails, courthouses with cells, and similar occupancies.

(b) Public assembly occupancy, as used in this chapter, shall apply to that portion of the premises in which persons congregate for civic, political, educational, religious, social, or recreational purposes, including, but not limited to, armories, assembly rooms, auditoriums, ballrooms, bath houses, bus terminals, broadcasting studios, churches, colleges, court-houses without cells, dance halls, department stores, exhibition halls, fraternity halls, libraries, lodge rooms, mortuary chapels, museums, passenger depots, schools, skating rinks, subway stations, theaters, enclosed portions of arenas, race tracks and stadiums, and similar occupancies.

(c) Residential occupancy, as used in this chapter, shall apply to that portion of the premises in which sleeping accommodations are provided, including but not limited to, clubhouses, convents, dormitories, hotels, lodging houses, multiple story apartments, residences, studios, tenements, and similar occupancies.

(d) Commercial occupancy, as used in this chapter, shall apply to that portion of the premises used for the transaction of business; for the rendering of professional services; for the supplying of food, drink, or other bodily needs and comforts; for manufacturing purposes or for the performance of work or labor except as included under par. (e), including, but not limited to, bake shops, fur storage, laboratories, loft buildings, markets, office buildings, professional buildings, restaurants, stores other than department stores, and similar occupancies.

(e) Industrial occupancy, as used in this chapter, shall apply to an entire building or premises or to that portion of a building used for manufacturing, processing, or storage of materials or products, including, but not limited to, chemical, food, candy and ice cream factories, ice-making plants, meat packing plants, refineries, perishable food warehouses and similar occupancies. In an industrial occupancy, when the number of persons in a refrigerated space, served by a direct system, on any floor above the first floor (ground level or deck level) exceeds one person per 100 square feet of floor area, the requirements of commercial occupancy shall apply unless that refrigerated space containing more than one person per 100 square feet of floor area, above the first floor is provided with the required number of doors opening directly into approved building exits.

Such refrigerated space shall be cut off from the rest of the building by tight construction with tight-fitting doors.

Note: The above does not prohibit openings for the passage of products from one refrigerated space to another refrigerated space.

(f) Mixed occupancy, as used in this chapter, shall apply to a building occupied or used for different purposes in different parts. When the occupancies are cut off from the rest of the building by tight partitions, floors, and ceilings and protected by self-closing doors, the requirements for each type of occupancy shall apply for its portion of the building or premises. When the occupancies are not so separated, the occupancy carrying the more stringent requirements shall govern.

Note: For example, the cold storage spaces in retail frozen food lockers, hotels, and department stores might be classified under industrial occupancy, whereas other portions of the building would be classified under other occupancies.

(2) **ADJACENT LOCATIONS.** Refrigerating equipment, other than piping, installed in locations adjacent to areas specified in sub. (1) and located outside of, but less than 20 feet from any building opening, shall be governed by the occupancy classification of the building. Refrigerating equipment installed in a nonadjacent location, such as equipment in a separate building located 20 feet or more from an opening in any other building, shall be governed by the provisions of sub. (1).

History: Cr. Register, September, 1983, No. 333, eff. 10-1-83.

ILHR 45.16 Refrigerating system classification. Refrigerating systems shall be classified by the method employed for extracting heat as follows:

(1) **DIRECT SYSTEM.** Direct system is one in which the evaporator is in direct contact with the material or space refrigerated or is located in air-circulating passages communicating with such spaces.

(2) **DOUBLE DIRECT SYSTEM.** Double direct system is one in which an evaporative refrigerant is used in a secondary circuit to condense or cool a refrigerant in a primary circuit. For the purpose of this chapter, each system enclosing a separate body of an evaporative refrigerant shall be considered as a separate direct system.

(3) **INDIRECT SYSTEM.** Indirect system is one in which a brine cooled by the refrigerant, is circulated to the material or space refrigerated or is used to cool air so circulated. Indirect systems which are distinguished by the type or method of application shall be as given in the following paragraphs:

(a) Indirect open-spray system is one in which a brine cooled by an evaporator located in an enclosure external to a cooling chamber is circulated to such cooling chamber, and is sprayed therein.

(b) Indirect closed-surface system is one in which a brine cooled by an evaporator located in an enclosure external to a cooling chamber, is circulated to and through such a cooling chamber in pipes or other closed circuits.

(c) Indirect vented closed-surface system is one in which a brine cooled by an evaporator located in a vented enclosure external to a cooling chamber, is circulated to and through such cooling chamber in pipes or other closed circuits.

(d) Double indirect vented open-spray system is one in which a brine cooled by an evaporator located in a vented enclosure, is circulated through a closed circuit to a second enclosure where it cools another supply of a brine and this liquid in turn is circulated to a cooling chamber and is sprayed therein.

Note: The different types of refrigerating systems are illustrated in Figure 45.16.

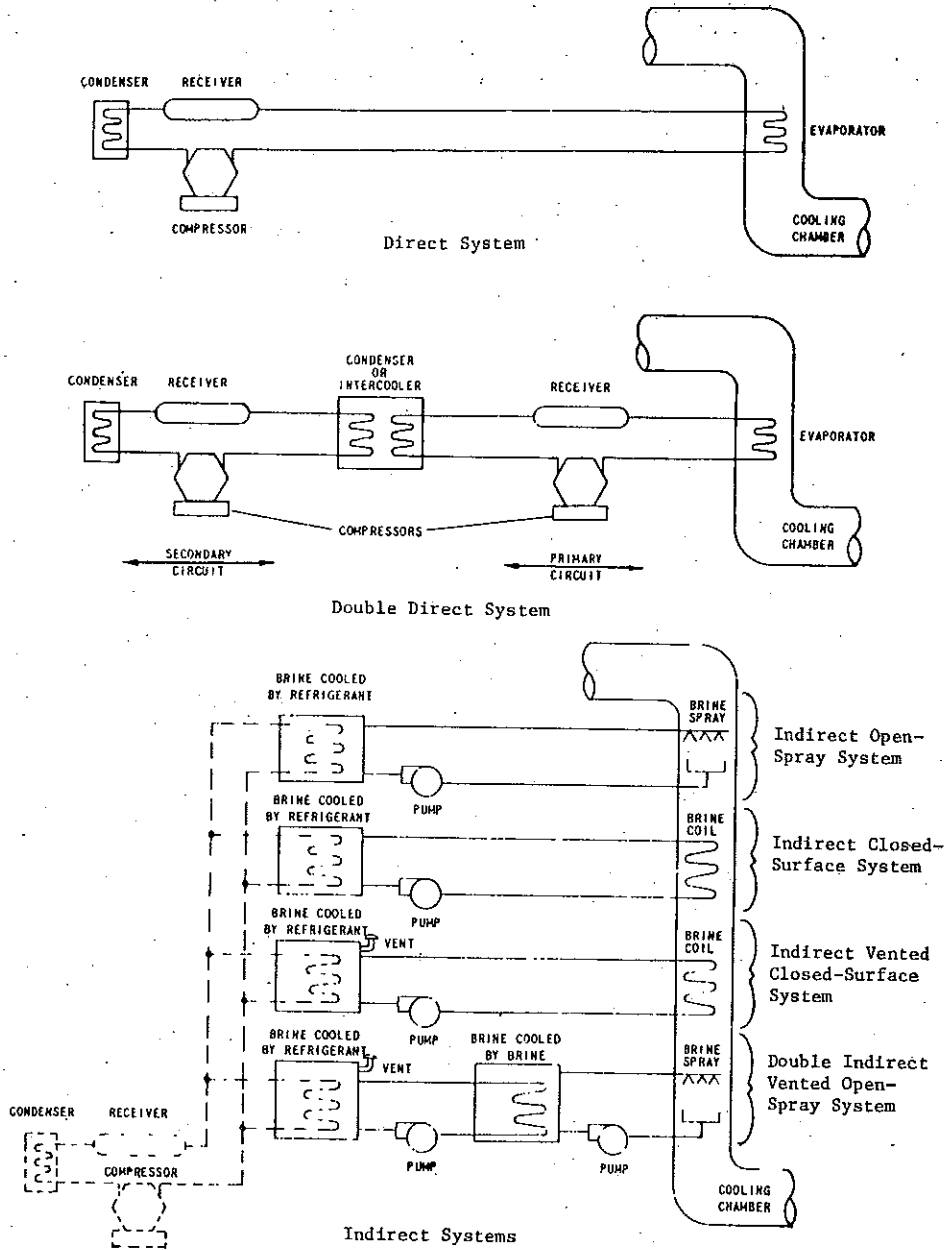

FIGURE 45.16
TYPES OF REFRIGERATING SYSTEMS

History: Cr. Register, September, 1983, No. 333, eff. 10-1-83.

DEPT. OF INDUSTRY, LABOR & HUMAN RELATIONS 13
ILHR 45

ILHR 45.17 Refrigerant classification. (1) GENERAL. Refrigerants shall be classified by their toxicity or flammability and are divided into groups as specified in Table 45.17.

Table 45.17
REFRIGERANT GROUPS

Refrigerant	Name	Chemical Formula
Group 1		
R-11	Trichlorofluoromethane.....	CCl_3F
R-12	Dichlorodifluoromethane.....	CCl_2F_2
R-13	Chlorotrifluoromethane.....	CClF_3
R-13B1	Bromotrifluoromethane.....	CBrF_3
R-14	Tetrafluoromethane.....	CF_4
R-21	Dichlorofluoromethane.....	CHCl_2F
R-22	Chlorodifluoromethane.....	CHClF_2
R-30	Dichloromethane (Methylene chloride).....	CH_2Cl_2
R-113	Trichlorotrifluoroethane.....	$\text{CCl}_2\text{FCClF}_2$
R-114	Dichlorotetrafluoroethane.....	$\text{CClF}_2\text{CClF}_2$
R-115	Chloropentafluoroethane.....	CClF_2CF_3
R-C318	Octafluorocyclobutane.....	C_4F_8
R-500	Dichlorodifluoromethane, 73.8% and Ethylidene Difluoride, 26.2%.....	$\text{CCl}_2\text{F}_2/\text{CH}_3\text{CHF}_2$
R-502	Chlorodifluoromethane, 48.8% and Chloropentafluoroethane, 51.2%.....	$\text{CHClF}_2/\text{CClF}_2\text{CF}_3$
R-503	Trifluoromethane, 40.1% and Chlorotrifluoromethane, 59.9%.....	$\text{CHF}_3/\text{CClF}_3$
R-744	Carbon Dioxide.....	CO_2
Group 2		
R-40	Methyl chloride.....	CH_3Cl
R-611	Methyl formate.....	HCOOCH_3
R-717	Ammonia.....	NH_3
R-764	Sulphur dioxide.....	SO_2
Group 3		
R-170	Ethane.....	C_2H_6
R-290	Propane.....	C_3H_8
R-600	Butane.....	C_4H_{10}
R-600a	Isobutane.....	$\text{CH}(\text{CH}_3)_3$
R-1150	Ethylene.....	C_2H_4
R-1270	Propylene.....	C_3H_6

Note #1: Methylene chloride (R-30) has a relatively high toxicity compared to the other Group 1 refrigerants.

Note #2: For further explanatory information, see ANSI/ASHRAE Standard 34-1978, "Number Designation of Refrigerants".

(2) OTHER REFRIGERANTS. Refrigerants, other than water and air, not listed in Table 45.17, shall not be used until approved by the department and assigned a group classification.

History: Cr. Register, September, 1983, No. 333, eff. 10-1-83.

Register, September, 1983, No. 333
Mechanical Refrigeration

ILHR 45.18 Requirements for institutional, public assembly, residential, and commercial occupancies. Unless otherwise specified, the requirements of this section shall apply to all institutional, public assembly, residential and commercial occupancies.

(1) **STAIRS AND EXITS.** No portion of a refrigerating system may be installed in or on a public stairway, stair landing, entrance, or exit.

(2) **HALLWAYS AND LOBBIES.** No portion of a refrigerating system may interfere with free passage through a public hallway or lobby. No portion of a refrigerating system containing a Group 2 refrigerant may be permitted in public hallways or lobbies of institutional or public assembly occupancies. Refrigerating systems installed in a public hallway or lobby shall be limited to:

(a) Unit systems containing not more than the quantities of a Group 1 refrigerant specified in Table 45.18-1; and

(b) Sealed absorption systems containing not more than 3 pounds of a Group 2 refrigerant when in residential and commercial occupancies.

(3) **ENCLOSED SPACES.** When the refrigerant-containing parts of a system are located in one or more enclosed spaces, the cubical content of the smallest enclosed humanly occupied space other than the machinery room, shall be used to determine the permissible quantity of refrigerant in the system. Where a refrigerating system has evaporator coils serving individual stories of a building, the story having the smallest volume shall be used to determine the maximum quantity of refrigerant in the entire system.

(4) **AIR DUCT SYSTEM.** When the evaporator is located in an air duct system, the cubical content of the smallest humanly occupied enclosed space served by the air duct system shall be used to determine the permissible quantity of refrigerant in the system. If the air flow to any enclosed space served by the air duct system cannot be shut off or reduced below one-quarter of its maximum, the cubical contents of the entire space served by the air duct system may be used to determine the permissible quantity of refrigerant in the system.

(5) **SUSPENDED CEILING.** Where the return air space above a suspended ceiling is one continuous space and not an enclosed air duct in which the return air is confined, this space may be included in calculating the cubical content of the humanly occupied space.

(6) **PRESSURE-RELIEF DEVICE.** In institutional and public assembly occupancies, direct expansion coils or evaporators used for air conditioning and located downstream from, and in proximity to, a heating coil, or located upstream within 18 inches of a heating coil, shall be fitted with a pressure-relief device discharging to the outside of the building in an approved manner; except that such a relief device shall not be required on unit or self-contained systems if the internal volume of the low side of the system which may be shut off by valves, divided by the total weight of refrigerant in the system less the weight of refrigerant vapor contained in the other parts of the system at 110° F., exceeds the specific volume of the refrigerant at critical conditions of temperature and pressure.

Note: The above exemption is stated in formula form as follows:

$$V_1/W_1 - W_2 \text{ is to be more than } V_{gc}$$

where V_1 = low side volume, cubic feet

V_{gc} = specific volume at critical conditions of temperature and pressure, cubic feet per pound

W_1 = total weight of refrigerant in system, pounds

V_2 = total volume of system less V_1 , cubic feet

V = specific volume of refrigerant vapor at 110° F., cubic feet per pound

$W_2 = V_2/V_g =$ weight of refrigerant vapor in V_2 at 110° F., pounds

(7) GROUP 1 REFRIGERANTS FOR DIRECT SYSTEMS. (a) The maximum permissible quantity of a Group 1 refrigerant in a direct system shall be as specified in Table 45.18-1 except for additional limitations specified in par. (b) for institutional occupancies.

(b) Direct systems in institutional occupancies shall be limited to systems each containing not more than 50% of the permissible quantities of Group 1 refrigerants specified in Table 45.18-1, except in kitchens, laboratories and mortuaries.

Table 45.18-1
MAXIMUM PERMISSIBLE QUANTITIES OF GROUP 1 REFRIGERANTS
FOR DIRECT SYSTEMS

Refrigerant		Maximum Quantity in Pounds per 1000 Cubic Feet of Humanly Occupied Space*
R-11	Trichlorofluoromethane.....	35
R-12	Dichlorodifluoromethane.....	31
R-13	Chlorotrifluoromethane.....	27
R-13B1	Bromotrifluoromethane.....	38
R-14	Tetrafluoromethane.....	23
R-21	Dichlorofluoromethane.....	13
R-22	Chlorodifluoromethane.....	22
R-30	Dichloromethane, (Methylene chloride).....	6
R-113	Trichlorotrifluoroethane.....	24
R-114	Dichlorotetrafluoroethane.....	44
R-115	Chloropentafluoroethane.....	40
R-C318	Octafluorocyclobutane.....	50
R-500	Dichlorodifluoromethane, 73.8% and Ethylidene Difluoride, 26.2%.....	26
R-502	Chlorodifluoromethane, 48.8% and Chloropentafluoroethane, 51.2%.....	30
R-503	Trifluoromethane, 40.1% and Chlorotrifluoromethane 59.9%.....	22
R-744	Carbon dioxide.....	11

*Volatile charge in a control shall not be considered as refrigerant.

(8) GROUP 1 REFRIGERANTS FOR INDIRECT SYSTEMS. A system containing more than the quantity of a Group 1 refrigerant allowed in Table 45.18-1 shall be of the indirect type. All refrigerant-containing parts, except piping, shall be installed in a machinery room or installed outside the building. Piping shall be installed in accordance with s. ILHR 45.23 (11). The machinery room shall be used for mechanical equipment only.

(9) OPEN FLAMES IN MACHINERY ROOMS. No open flames or apparatus to produce an open flame may be installed in a machinery room where any refrigerant other than carbon dioxide is used unless the flame is enclosed so that the products of combustion are vented to the open air. The use of matches, cigarette lighters, halide leak detectors, and similar devices shall not be considered a violation of this subsection or of sub. (10).

(10) **OPEN FLAMES IN INSTITUTIONAL OCCUPANCIES.** In institutional occupancies where more than one pound of a Group 1 refrigerant, other than carbon dioxide, is used in a system any portion of which is in a room where there is an apparatus for producing an open flame, then such refrigerant shall be classed in Group 2, unless the flame-producing apparatus is provided with a hood and flue capable of removing the products of combustion to the open air.

(11) **GROUP 2 REFRIGERANTS FOR DIRECT SYSTEMS.** Direct systems containing Group 2 refrigerants shall not be used for air conditioning for human comfort. For other applications, the maximum permissible quantity of Group 2 refrigerants in a direct system shall be as specified in Table 45.18-2.

Table 45.18-2
MAXIMUM PERMISSIBLE QUANTITIES OF GROUP 2 REFRIGERANTS
FOR DIRECT SYSTEMS

Type of Refrigerating System	Maximum Pounds for Various Occupancies			
	Institutional	Public Assembly	Residential	Commercial
Sealed Absorption Systems:				
a) In public hallways or lobbies	0	0	3	3
b) In other than public hallways or lobbies	0*	6	6	20
Self-Contained or Unit Systems:				
a) In public hallways or lobbies	0	0	0	0
b) In other than public hallways or lobbies	0	0*	6	20

*6 pounds allowed when installed in kitchens, laboratories, and mortuaries.

(12) **GROUP 2 REFRIGERANTS FOR INDIRECT SYSTEMS.** (a) Except as provided in par. (b) or par. (c) 2., the maximum permissible quantity of a Group 2 refrigerant in any indirect system shall be as specified in Table 45.18-3. Except as provided in par. (b), such systems shall be of the following type:

1. Institutional and public assembly occupancies - indirect vented closed-surface, or double indirect vented open-spray.

2. Residential and commercial occupancies - indirect closed-surface, indirect vented closed surface, or double indirect vented open-spray, or secondary circuit of double direct type.

Table 45.18-3
MAXIMUM PERMISSIBLE QUANTITIES OF GROUP 2 REFRIGERANTS
FOR INDIRECT SYSTEMS

Occupancy	Class T Machinery Rooms Max. Pounds
Institutional	500
Public Assembly	1000
Residential.....	No Limit
Commercial	No Limit

(b) Indirect systems using Group 2 refrigerants and conforming with the provisions of sub. (11) for direct systems shall be permitted.

(c) 1. Indirect systems using Group 2 refrigerants not in excess of the quantities shown in Table 45.18-3, other than such systems conforming with the provisions of par. (b), or subd. 2., shall have all refrigerant-containing parts, except piping, installed in a Class T machinery room, except that an air-cooled or evaporative condenser may be installed outside the building. Piping shall be installed in accordance with s. ILHR 45.23 (11). The Class T machinery room shall be used for mechanical equipment only.

2. A sealed ammonia-water absorption unit system containing not more than 20 pounds of ammonia and installed outdoors adjacent to a commercial or residential occupancy shall not be required to conform with provisions of subd. 1.

(d) Where a Class T machinery room is provided to comply with par. (c) 1. to house a refrigerating system containing any Group 2 refrigerant other than sulphur dioxide, no flame-producing device or hot surface above 800° F. shall be permitted in such room and all electrical equipment in the room shall conform to the requirements of hazardous locations class 1, division 2, of ch. ILHR 16. The use of matches, cigarette lighters, halide leak detectors, combustion engines, gas turbines and similar devices shall not be considered a violation of this paragraph, provided the quantities of Group 2 refrigerants in Table 45.18-4 are not exceeded.

(e) Group 2 refrigerants listed in Table 45.18-4 shall not be used in a refrigerating system in excess of 1000 pounds unless approved by the department.

Table 45.18-4
MAXIMUM PERMISSIBLE QUANTITIES OF FLAMMABLE REFRIGERANTS

Refrigerant	Group	Name	Maximum Quantity in Pounds per 100 Cubic Feet of Room Volume
R-40	2	Methyl chloride.....	10
R-611	2	Methyl formate.....	7
R-170	3	Ethane	2½
R-290	3	Propane.....	2½
R-600	3	Butane	2½
R-600a	3	Isobutane	2½
R-1150	3	Ethylene	2
R-1270	3	Propylene.....	2

(13) GROUP 3 REFRIGERANTS. Group 3 refrigerants shall not be used in institutional, public assembly, residential, or commercial occupancies except in laboratories for commercial occupancies. In such laboratory installations, only unit systems containing not more than 6 pounds shall be used unless the number of persons does not exceed one person per 100 square feet of laboratory floor area, in which case the requirements of s. ILHR 45.19 shall apply.

History: Cr. Register, September, 1983, No. 333, eff. 10-1-83.

Register, September, 1983, No. 333
Mechanical Refrigeration

ILHR 45.19 Requirements for industrial occupancies. (1) **GENERAL.** Except as specified in subs. (2) to (5), there shall be no restrictions on the quantity or kind of refrigerant used in an industrial occupancy.

(2) **OPEN FLAMES.** When the quantity of flammable refrigerant in any one refrigerating system exceeds the amount given in Table 45.18-4 for each 1000 cubic feet of room volume in which the system, or any part thereof is installed, then no flame producing device or hot surface above 800° F. may be permitted and this room shall be considered a class 1, division 2 location, and all electrical equipment in the room shall conform to the requirements for a class 1, division 2 location in accordance with ch. ILHR 16.

(3) **FLAMMABLE REFRIGERANTS.** Flammable refrigerants as listed in Table 45.18-4, shall not be used in a refrigerating system in excess of 1000 pounds unless approved by the department.

(4) **AMMONIA SYSTEMS.** When ammonia is used in a refrigerating system, all refrigerant-containing parts, except pressure vessels utilized for heat recovery purposes, piping and evaporators, and except refrigerant-containing components installed outside the building, shall be installed in a machinery room under the conditions of par. (a), (b) or (c), and the machinery room shall have no flame-producing apparatus permanently installed and operated.

Note: See s. ILHR 45.23 (12) for complete machinery room requirements.

(a) The machinery room shall be provided with a continuously operated, independent mechanical ventilation system, and this room shall be considered a "nonhazardous (unclassified) location" in accordance with ch. ILHR 16. Failure of the mechanical ventilation system shall also initiate a supervised alarm so corrective action can be initiated.

(b) The machinery room shall be provided with an independent mechanical ventilation system actuated automatically by a vapor detector when the concentration of ammonia in the room exceeds 40,000 parts per million, and also operable manually, and this room shall be considered a "nonhazardous (unclassified) location" in accordance with ch. ILHR 16. The vapor detector shall also initiate a supervised alarm so corrective action can be initiated. Periodic tests of the complete detector, alarm, mechanical ventilation system shall be performed.

(c) Where mechanical ventilation is not provided in accordance with par. (a) or (b), the machinery room shall be considered a class 1, division 2 location, and all electrical equipment in the room shall conform to the requirements for a class 1, division 2 location in accordance with ch. ILHR 16.

(5) **REFRIGERATED STORAGE AREAS AND WORK AREAS.** (a) Except as specified in subs. (2) and (3), there shall be no additional requirements for refrigerant-containing components in refrigerated storage areas for any refrigerant.

(b) In refrigerated work areas where refrigerants in Table 45.18-4 are used, the area shall be considered a class 1, division 2 location, and all electrical equipment in the room shall conform to the requirements for a class 1, division 2 location in accordance with ch. ILHR 16.

1. When any refrigerant other than those listed in Table 45.18-4 is used, the area shall be considered a "nonhazardous (unclassified) location" in accordance with ch. ILHR 16.

2. When any Group 2 or Group 3 refrigerant is used, means shall be taken to adequately safeguard piping, controls and other refrigeration equipment in working areas to minimize the possibility of accidental damage or rupture from external sources.

3. Areas through which piping for a Group 2 or Group 3 refrigerant is run shall be considered a refrigerated work area.

History: Cr. Register, September, 1983, No. 333, eff. 10-1-83.

ILHR 45.20 Design and construction of equipment. (1) **MATERIALS.** All materials used in the construction and installation of refrigerating systems shall be suitable for conveying the refrigerant used. Some refrigerants are corrosive to the usual materials when moisture or air, or both, are present. No material may be used that will deteriorate because of the refrigerant or the oil, or the combination of both.

(a) Aluminum, zinc or magnesium shall not be used in contact with methyl chloride in a refrigerating system. Magnesium alloys shall not be used in contact with any halogenated refrigerant.

(b) Copper and its alloys shall not be used in contact with ammonia except as a component of bronze alloys for compressor parts or similar uses where compatibility has been established

(2) **DESIGN PRESSURE.** (a) Design pressures shall be selected high enough for all operating and standby conditions. Minimum design pressure shall not be less than 15 psig and except as noted in pars. (b), (c) and (d), shall not be less than the saturation pressure of the refrigerant at the following temperatures:

1. Low sides of all systems = 80° F.

2. High side of water or evaporatively cooled systems = 105° F.

3. High sides of air-cooled systems = 125° F.

Note #1: When selecting the design pressure, consideration should be given to allowances for setting pressure-limiting devices and pressure-relief devices sufficiently above operating conditions to avoid nuisance shutdowns and for shipping conditions.

Note #2: Corresponding pressures are given in Table 45.20 for the refrigerants in common use.

Note #3: All operating conditions are intended to cover maximum pressures attained under any anticipated normal operating conditions.

Note #4: Standby conditions are intended to include conditions which may be attained in the system when not operating, including pressure developed in the low side of the system resulting from equalization after the system has stopped.

Note #5: Shipping conditions are intended to include consideration of maximum pressures attainable due to anticipated environmental conditions during transit.

(b) The design pressure for either the high or low side need not exceed the critical pressure of the refrigerant unless the system is intended to operate at these conditions.

(c) When a part of a limited charged system is protected by a pressure-relief device, the design pressure of that part need not exceed the setting of the pressure-relief device.

(d) When a compressor is used as a booster to obtain a low pressure and discharges into the suction side of another system, the booster compressor shall be considered a part of the low side provided that a low pressure stage compressor of the positive displacement type is protected by a pressure-relief device.

(e) Any components connected to pressure vessels shall have a design pressure equal to or greater than the pressure vessels.

Table 45.20
MINIMUM* DESIGN PRESSURES (PSIG)

Refrigerant	Name	Low Side	High Side	
			Evap. or Water Cooled	Air Cooled
R-11	Trichlorofluoromethane	15	15	21
R-12	Dichlorodifluoromethane	85	127	169
R-13	Chlorotrifluoromethane	521	547	547
R-13B1	Bromotrifluoromethane	230	321	410
R-14	Tetrafluoromethane	544	544	544
R-21	Dichlorofluoromethane	15	29	46
R-22	Chlorodifluoromethane	144	211	278
R-30	Methylene Chloride	15	15	15
R-40	Methyl Chloride	72	112	151
R-113	Trichlorotrifluoroethane	15	15	15
R-114	Dichlorotetrafluoroethane	18	35	53
R-115	Chloropentafluoroethane	152	194	252
R-170	Ethane	616	709	709
R-290	Propane	129	188	244
R-C318	Octafluorocyclobutane	34	59	85
R-500	Dichlorodifluoromethane, 73.8% and Ethylidene Difluoride, 26.2%	102	153	203
R-502	Chlorodifluoromethane, 48.8% and Chloropentafluoromethane, 51.2%	162	232	302
R-503	Trifluoromethane, 40.1% and Chlorotrifluoromethane 59.9%	617	617	617
R-600	N-Butane	23	42	61
R-600a	Isobutane	39	63	88
R-611	Methyl Formate	15	15	15
R-717	Ammonia	139	215	293
R-744	Carbon Dioxide	955	1058	1058
R-764	Sulfur Dioxide	45	78	115
R-1150	Ethylene	732	732	732
R-1270	Propylene	160	228	294

*Selection of higher design pressures may be required to satisfy actual shipping, operating or standby conditions.

(3) REFRIGERANT-CONTAINING PRESSURE VESSELS. (a) Pressure vessels exceeding 6 inches inside diameter and having a maximum internal or external design pressure greater than 15 psig shall comply with the rules of section VIII of the ASME boiler and pressure vessel code as adopted by reference in chs. Ind 41-42, covering the requirements for the design, fabrication, inspection and testing during construction of unfired pressure vessels.

(b) Pressure vessels not exceeding 6 inches inside diameter, except those having a maximum internal or external design pressure of 15 psig or less, shall be listed either individually or as part of refrigeration equipment by an approved nationally recognized testing laboratory, or shall meet the design, fabrication, and testing requirements of section VIII of the ASME boiler and pressure vessel code as adopted by reference in chs. Ind 41-42.

(c) Except as specified in pars. (d) and (e), pressure vessels having a maximum internal or external design pressure of 15 psig or less shall have an ultimate strength to withstand at least 3 times the design pressure and shall be tested to at least 1-1/3 times the design pressure for which they are rated.

(d) If a pressure-relief device is used to protect a pressure vessel not exceeding 6 inches inside diameter, the ultimate strength of the pressure vessel so protected shall be sufficient to withstand at least 2-1/2 times the pressure setting of the pressure-relief device.

(e) If a fusible plug is used to protect a pressure vessel not exceeding 6 inches inside diameter, the ultimate strength of the pressure vessel so protected shall be sufficient to withstand at least 2-1/2 times the refrigerant saturation pressure corresponding to the stamped temperature on the fusible plug, or at least 2-1/2 times the critical pressure of the refrigerant used, whichever is smaller.

(f) Secondhand refrigerant-containing pressure vessels shall comply with the requirements of ss. Ind 42.25 to 42.33.

(g) The welded repair or alteration to refrigerant-containing pressure vessels shall comply with the requirements of ss. Ind 42.01 to 42.17.

(4) REFRIGERANT PIPING, VALVES AND FITTINGS. (a) Refrigerant piping, valves, fittings, and related parts, having a maximum internal or external design pressure greater than 15 psig shall be listed either individually or as part of refrigeration equipment by an approved nationally recognized laboratory, or shall comply with the ANSI Code for Refrigeration Piping B31.5 where applicable. In either case, the additional requirements of pars. (b) to (e) shall apply.

(b) Specific minimum requirements for unprotected refrigerant pipe or tubing shall be as follows:

1. Unprotected seamless drawn temper copper water tube used for refrigerant piping erected on the premises shall conform to ASTM Specification B88 Types K or L for specifications, dimensions and tolerances.

2. Unprotected soft annealed copper tubing used for refrigerant piping erected on the premises shall conform to and shall be limited to the sizes and wall thicknesses and tolerances specified in ASTM Specification B280.

(c) Rigid or flexible metal enclosures shall be provided for soft, annealed copper tubing used for refrigerant piping erected on the premises and containing Group 2 or 3 refrigerants, except that no enclosures shall be required for connections between a condensing unit and the nearest protected riser, provided such connections do not exceed 6 feet in length.

(d) Joints which are made by the addition of filler metal shall be brazed on refrigerant copper pipe and tubing in refrigerating systems containing Group 2 or Group 3 refrigerants, and may be brazed or soldered in refrigerating systems containing Group 1 refrigerants.

(5) COMPONENTS OTHER THAN PRESSURE VESSELS AND PIPING. (a) Every pressure-containing component of a refrigerating system other than pressure vessels, piping, pressure gages and control mechanisms, shall be listed either individually or as part of refrigeration equipment by an approved nationally recognized testing laboratory, or shall be designed, constructed and assembled to have an ultimate strength sufficient to withstand at least 3 times the design pressure for which it is rated.

(b) Liquid level gage glasses, except those of the bull's eye or reflex type, shall have automatic closing shut-off valves, and such glasses shall be protected against damage.

(c) The dial of a pressure gage, when the gage is permanently installed on the high side of a refrigerating system, shall be graduated to at least 1.2 times the design pressure.

(d) Liquid receivers or parts of a system designed to receive the refrigerant charge during pumpdown, shall have sufficient capacity to receive the charge without the liquid occupying more than 90% of the volume when the temperature of the refrigerant is 90° F.

(e) Butt welded steel, other than open hearth type which is not rephosphorized, or wrought iron pipe shall not be used for evaporator or condenser coils.

(6) SERVICE PROVISIONS. (a) All systems shall have provisions to handle safely the refrigerant charge for service purposes.

Note: Properly located stop valves, separate storage tanks or adequate venting for safe disposal are satisfactory for this purpose.

(b) Systems containing more than 6 pounds of a Group 2 or 3 refrigerant, other than systems utilizing nonpositive displacement compressors, shall have stop valves installed at the following locations:

1. Each inlet of each compressor, compressor unit, or condensing unit; and
2. Each discharge outlet of each compressor, compressor unit, or condensing unit, and of each liquid receiver.

Note: All systems containing 100 pounds or more of refrigerant, other than systems utilizing nonpositive displacement compressors, should have stop valves at the locations specified in par. (b), and on each inlet of each liquid receiver, except on the inlet of a receiver in a condensing unit or on the inlet of a receiver which is an integral part of a condenser.

(c) Stop valves used with soft annealed copper tubing or hard drawn copper tubing 7/8-inch outside diameter or smaller shall be securely mounted, independent of tubing fastenings or supports.

(d) Stop valves shall be suitably labeled if it is not obvious what they control. Numbers may be used to label the valves provided a key to the numbers is located near the valves.

(7) **FACTORY TESTS.** (a) Except as provided in pars. (b) and (c), every refrigerant-containing part of every system shall be tested and proved tight by the manufacturer at not less than the design pressure for which it is rated.

(b) Pressure vessels shall be tested in accordance with sub. (3).

(c) 1. The test pressure applied to the high side of each factory-assembled refrigerating system shall be at least equal to the design pressure of the component in the high side which has the lowest rated design pressure. The test pressure applied to the low side of each factory-assembled refrigerating system shall be at least equal to the design pressure of the component in the low side which has the lowest rated design pressure.

2. In testing systems using nonpositive displacement compressors, the entire system shall be considered for test purposes as the low side pressure.

(8) **NAMEPLATE.** Each unit system and each separate condensing unit, compressor or compressor unit sold for field assembly in a refrigerating system shall carry a nameplate marked with the manufacturer's name, nationally registered trademark or trade name, identification number, the design pressures, and the refrigerant for which it is designed.

History: Cr. Register, September, 1983, No. 333, eff. 10-1-83.

ILHR 45.21 Pressure-limiting devices. (1) **GENERAL.** Pressure-limiting devices shall be provided on all systems containing more than 20 pounds of refrigerant and operating above atmospheric pressure and on all water-cooled systems so constructed that the compressor or generator is capable of producing a pressure in excess of the high side design pressure except water-cooled unit systems containing not more than 3 pounds of a Group 1 refrigerant providing the operating pressure developed in the system with the water supply shut off does not exceed one-fifth the ultimate strength of the system, or providing an overload device will stop the action of the compressor before the pressure exceeds one-fifth the ultimate strength of the system.

(2) **MAXIMUM SETTING.** (a) When required by sub. (1), the maximum setting to which a pressure-limiting device may readily be set by use of the adjusting means provided shall not exceed the design pressure of the high side of a system which is not protected by a pressure relief device or 90% of the setting of the pressure-relief device installed on the high side of the system except as provided in par. (b). The pressure-limiting device shall stop the action of the pressure imposing element at a pressure no higher than this maximum setting.

(b) On systems using nonpositive displacement compressors, the pressure-limiting device may be set at the design pressure of the high side of the system provided the pressure-relief device is:

1. Located in the low side;
2. Subject to low side pressure; and
3. There is a permanent unvalved relief path between the high side and the low side of the system.

ILHR 45

(3) **DEVICE LOCATION.** When required by sub. (1), pressure-limiting devices shall be connected between the pressure-imposing element and any stop valve on the discharge side with no intervening stop valves in the line leading to the pressure-limiting device.

History: Cr. Register, September, 1983, No. 333, eff. 10-1-83.

ILHR 45.22 Pressure-relief protection. (1) **GENERAL.** Every refrigerating system shall be protected by a pressure-relief device or some other means designed to safely relieve pressure due to fire or other abnormal conditions. In addition, all pressure vessels shall be protected in accordance with the requirements of sub. (4).

(a) All pressure-relief devices, not fusible plugs, shall be direct pressure actuated. Each part of a refrigerating system which can be valved off and which contains one or more pressure vessels having internal diameters greater than 6 inches and containing liquid refrigerant shall be protected by a pressure-relief device.

(b) Stop valves shall not be located between the means of pressure relief and the part or parts of the system protected thereby except when the parallel relief devices specified in sub. (4) (b) are so arranged that only one can be rendered inoperative at a time for testing or repair purposes.

(c) All pressure-relief devices and fusible plugs shall be connected as nearly as practicable directly to the pressure vessel or other parts of the system protected thereby, above the liquid refrigerant level, and installed so that they are readily accessible for inspection and repair and so that they cannot be readily rendered inoperative. Fusible plugs may be located above or below the liquid refrigerant level except on the low side.

(d) The seats and discs of pressure-relief devices shall be constructed of suitable material to resist refrigerant corrosion or other chemical action caused by the refrigerant. Seats or discs of cast iron shall not be used.

(2) **SETTING OF RELIEF DEVICES.** (a) All pressure-relief valves shall be set to start to function at a pressure not to exceed the design pressure of the parts of the system protected.

(b) All rupture members used in lieu of, or in series with, a relief valve shall have a nominal rated rupture pressure not to exceed the design pressure of the parts of the systems protected.

1. The conditions of application shall conform to the requirements of section VIII, division 1, of the ASME boiler and pressure vessel code as adopted by reference in chs. Ind 41-42.

2. Rupture members installed ahead of relief valves need not be larger, but shall not be smaller, than the relief valve inlet.

(3) **MARKING OF RELIEF DEVICES.** (a) All pressure-relief valves for refrigerant-containing components shall be set and sealed by the manufacturer or an assembler as defined in paragraph UG-136 (c) (4) of section VIII, division 1, of the ASME boiler and pressure vessel code as adopted by reference in chs. Ind 41-42. Each pressure-relief valve shall be marked by the manufacturer or assembler with the data required in paragraph UG-129 (a) of section VIII, division 1, of the ASME boiler and pressure vessel code as adopted by reference in chs. Ind 41-42, except relief valves

for systems with design pressures of 15 psig or less may be marked by the manufacturer, with the pressure setting and capacity.

(b) Each rupture member for refrigerant-containing pressure vessels shall be marked with the data required in paragraph UG-129 (d) of section VIII, division 1, of the ASME boiler and pressure vessel code as adopted by reference in chs. Ind 41-42.

(c) Fusible plugs shall be marked with the melting temperature in degrees F.

(d) Any repairs to pressure-relief devices shall be made by the manufacturer or manufacturer's authorized representative.

(4) **PRESSURE VESSEL PROTECTION.** (a) Pressure vessels shall be provided with pressure-relief protection in accordance with rules given in paragraphs UG-125 to UG-134 of section VIII, division 1, of the ASME boiler and pressure vessel code as adopted by reference in chs. Ind 41-42, with such additional modifications as are necessary for control of refrigerants.

(b) Each pressure vessel containing liquid refrigerant with internal gross volume exceeding 3 cubic feet except as specified in par. (d), and which may be shut off by valves from all other parts of a refrigerating system, shall be protected by a pressure-relief device, having sufficient capacity to prevent the pressure in the pressure vessel from rising more than 10% above the setting of the pressure-relief device.

1. Under conditions specified in par. (b) (intro), a single pressure-relief device may be used on pressure vessels having less than 10 cubic feet internal gross volume.

2. a. Under conditions specified in par. (b) (intro), if a pressure-relief valve is used, a relief device system consisting of a pressure-relief valve in parallel with a second pressure-relief valve as described in sub. (1) (b) shall be provided on pressure vessels having an internal gross volume of 10 cubic feet or over. Each pressure-relief valve shall have sufficient capacity to prevent the pressure in the pressure vessel from rising more than 10% above the setting of the pressure-relief valve.

b. Under conditions permitted in par. (h) 1., a single relief valve, not rupture member, of the required relieving capacity may be used on vessels of 10 cubic feet or over.

3. Except as specified in par. (d), in cases where large pressure vessels containing liquid refrigerant require the use of 2 or more pressure-relief devices in parallel to obtain the capacity required, the battery of pressure-relief devices shall be considered as a unit, and therefore as one pressure-relief device.

(c) Except as specified in par. (d), each pressure vessel having an internal gross volume of 3 cubic feet or less, containing liquid refrigerant and which may be shut off by valves from all other parts of a refrigerating system, shall be protected by a pressure-relief device, or fusible plug. Pressure vessels of less than 3 inches inside diameter are exempt from these requirements.

(d) Pressure vessels having internal diameters greater than 6 inches used as, or as part of, evaporators insulated or installed in insulated

space, and which may be shut off by valves from all other parts of a refrigerating system shall be protected by a pressure-relief device in accordance with the provisions of pars. (b) and (c), except that the provisions of par. (b) 2. a. requiring a second parallel pressure-relief valve, shall not apply. Pressure vessels used as evaporators, having internal diameters of 6 inches or less are exempt from pressure-relief device requirements.

(e) 1. The minimum required discharge capacity of the pressure-relief device or fusible plug for each pressure vessel shall be determined by the following:

$C = fDL$
 where C = minimum required discharge capacity of the relief device
 in pounds of air per minute
 D = outside diameter of the vessel in feet
 L = length of the vessel in feet
 f = factor dependent upon kind of refrigerant, as follows:

Kind of Refrigerant	Value of f
Ammonia (Refrigerant 717).....	0.5
Refrigerants 12, 22 and 500	1.6
Refrigerant 502, 503 and Refrigerants 13, 13B1 and 14 when on cascaded systems.....	2.5
All other refrigerants.....	1.0

2. When one pressure-relief device or fusible plug is used to protect more than one pressure vessel the required capacity shall be the sum of the capacities required for each pressure vessel.

(f) The rated discharge capacity of a pressure-relief valve, expressed in pounds of air per minute, shall be determined in accordance with paragraph UG-131 of section VIII, division 1, of the ASME boiler and pressure vessel code as adopted by reference in chs. Ind 41-42. All pipe and fittings between the pressure-relief valve and the parts of the system it protects shall have at least the area of pressure-relief valve inlet.

(g) The rated discharge capacity of a rupture member or fusible plug discharging to atmosphere under critical flow conditions in pounds of air per minute shall be determined by the following formulas:

$$C = 0.8 P_1 d^2$$

$$d = 1.12 C/P_1$$

where C = rated discharge capacity in pounds of air per minute
 d = smallest of the internal diameter of the inlet pipe, retaining flanges, fusible plug, or rupture member in inches

Where for rupture members:

$$P_1 = (\text{Rated pressure in psig} \times 1.10) + 14.7, \text{ in psia}$$

for fusible plugs:

$$P_1 = \text{absolute saturation pressure, corresponding to the stamped temperature melting point of the fusible plug or the critical pressure of the refrigerant used, whichever is smaller, in psia}$$

(h) Pressure relief devices and fusible plugs on any system containing a Group 3 refrigerant, on any system containing more than 6 pounds of a Group 2 refrigerant except as indicated in subd. 2. and on any system containing more than 100 pounds of a Group 1 refrigerant, shall discharge to the atmosphere at a location not less than 15 feet above the adjoining ground level and not less than 20 feet from any window, ventilation opening, or exit in any building. Discharge piping connected to the discharge side of a fusible plug or rupture member shall have provisions to prevent plugging the piping in the event the fusible plug or rupture member functions.

1. Pressure-relief valves may discharge into the low side of the system, provided the pressure-relief devices are of a type not appreciably affected by back pressures and provided the low side of the system is equipped with pressure-relief devices. The relief devices on the low side of the system shall have sufficient capacity to protect the pressure vessels that are relieved into the low side of the system, or to protect all pressure vessels on the low side of the system, whichever relieving capacity is the largest, as computed by the formula in par. (e). Such low side pressure-relief device shall be set in accordance with sub. (2) (a) and vented to the outside of the building in accordance with par. (h) (intro).

2. Where ammonia is used, the discharge may be into a tank of water which shall be used for no purpose except ammonia absorption. At least one gallon of fresh water shall be provided for each pound of ammonia in the system. The water used shall be prevented from freezing without the use of salt or chemicals. The tank shall be substantially constructed of not less than 1/8 inch or No. 11 U.S. gage iron or steel. No horizontal dimension of the tank shall be greater than one half the height. The tank shall have a hinged cover, or, if of the enclosed type, shall have a vent hole at the top. All pipe connections shall be through the top of the tank only. The discharge pipe from the pressure-relief valves shall discharge the ammonia in the center of the tank near the bottom. An indirect ammonia-water absorption unit system installed outdoors adjacent to a single family residence is not required to comply with par. (h) (intro) provided the discharge is shielded and dispersed.

3. Where sulphur dioxide is used, the discharge may be into a tank of absorptive brine which shall be used for no purpose except sulphur dioxide absorption. There shall be one gallon of standard dichromate brine which consists of 2-1/2 pounds of sodium dichromate per gallon of water, for each pound of sulphur dioxide in the system. Brines made with caustic soda or soda ash may be used in place of sodium dichromate provided the quantity and strength give the equivalent sulphur dioxide absorbing power. The tank shall be substantially constructed of not less than 1/8 inch or No. 11 U.S. gage iron or steel. The tank shall have a hinged cover, or, if of the enclosed type, shall have a vent hole at the top. All pipe connections shall be through the top of the tank only. The discharge pipe from the pressure-relief valve shall discharge the sulphur dioxide in the center of the tank near the bottom.

4. The size of the discharge pipe from the pressure-relief device or fusible plug shall not be less than the size of the pressure-relief device or fusible plug outlet. The discharge from more than one relief device or fusible plug may be run into a common header, the area of which shall be not less than the sum of the areas of the pipes connected thereto.

5. The length of the discharge piping permitted to be installed on the outlet of a pressure-relief device or fusible plug shall be determined as follows:

$$C = (3Pd^{5/2})/(L^{1/2})$$

$$d = [(C^2 L)/(9P^2)]^{1/5}$$

Where C = minimum required discharge capacity in pounds of air per minute

d = internal diameter of pipe in inches

L = length of discharge pipe in feet

P = 0.25P₁ [P₁ is defined under par. (g)]

Note: See Table 45.22 for computations derived from the preceding formula.

Table 45.22
LENGTH OF DISCHARGE PIPING FOR PRESSURE-RELIEF DEVICES
OF VARIOUS DISCHARGE CAPACITIES

Equivalent Length of Discharge Pipe, Feet (L)	Discharge capacity in pounds of air per minute (C) Standard wall iron pipe sizes in inches							
	½	¾	1	1¼	1½	2	2½	3
RELIEF DEVICE SET AT 25 PSIA (P₁)								
50	0.81	1.6	2.9	5.9	8.7	16.3	25.3	43.8
75	0.67	1.4	2.4	4.9	7.2	13.3	20.9	35.8
100	0.58	1.2	2.1	4.2	6.2	11.5	18.0	30.9
150	0.47	0.95	1.7	3.4	5.0	9.4	14.6	25.3
200	0.41	0.8	1.5	2.9	4.4	8.1	12.6	21.8
300	0.33	0.67	1.2	2.4	3.6	6.6	10.5	17.9
RELIEF DEVICE SET AT 50 PSIA (P₁)								
50	1.6	3.3	5.9	11.9	17.4	32.5	50.6	87.6
75	1.3	2.7	4.9	9.7	14.3	26.5	41.8	71.5
100	1.2	2.3	4.2	8.4	12.3	23.0	36.0	61.7
150	0.94	1.9	3.5	6.9	10.0	18.7	29.2	50.6
200	0.81	1.6	2.9	5.9	8.7	16.3	25.3	43.7
300	0.66	1.3	2.5	4.9	7.1	13.3	21.0	35.7
RELIEF DEVICE SET AT 75 PSIA (P₁)								
50	2.4	4.9	8.9	17.9	26.1	48.7	75.9	131.5
75	2.0	4.1	7.3	14.6	21.4	39.8	62.6	107.0
100	1.7	3.5	6.4	12.6	18.5	34.4	54.0	92.6
150	1.4	2.8	5.2	10.3	15.0	28.0	43.8	75.9
200	1.2	2.5	4.4	8.9	13.1	24.4	37.9	65.6
300	0.9	2.0	3.7	7.3	10.7	19.9	31.5	53.5
RELIEF DEVICE SET AT 100 PSIA (P₁)								
50	3.2	6.6	11.9	23.8	34.8	65.0	101.2	175.2
75	2.7	5.4	9.7	19.4	28.6	53.0	83.6	143.0
100	2.3	4.6	8.5	16.8	24.6	45.9	72.0	123.6
150	1.9	3.8	6.9	13.7	20.0	37.4	58.4	101.2
200	1.6	3.3	5.9	11.9	17.5	32.5	50.6	87.6
300	1.3	2.7	4.9	9.7	14.2	26.5	42.0	71.4
RELIEF DEVICE SET AT 150 PSIA (P₁)								
50	4.9	9.9	17.9	35.7	52.3	97.5	151.8	262.8
75	4.0	8.1	14.6	29.2	42.9	79.5	125.4	214.5
100	3.5	6.9	12.7	25.2	36.9	68.9	108.0	185.4
150	2.8	5.7	10.4	20.6	30.0	56.1	87.6	151.8
200	2.4	4.9	8.9	17.8	26.2	48.7	75.9	131.4
300	1.9	4.0	7.4	14.6	21.1	39.7	63.0	107.1
RELIEF DEVICE SET AT 200 PSIA (P₁)								
50	6.5	13.2	23.8	47.6	69.7	130.0	202.4	350.4
75	5.3	10.8	19.4	38.9	57.2	106.0	167.2	286.0
100	4.6	9.2	16.9	33.6	49.2	91.8	144.0	247.2
150	3.8	7.6	13.8	27.4	40.0	74.8	116.8	202.4
200	3.2	6.5	11.8	23.8	34.9	64.9	101.2	175.2
300	2.6	5.3	9.8	19.4	28.4	52.9	84.0	142.8

TABLE 45.22 (continued)

RELIEF DEVICE SET AT 250 PSIA (P ₁)								
50	8.1	16.5	29.8	59.5	87.1	162.5	253.0	437.0
75	6.7	13.5	24.3	48.6	71.5	132.5	209.0	357.5
100	5.8	11.6	21.2	42.0	61.6	114.8	180.0	309.0
150	4.7	9.5	17.3	34.3	50.0	93.5	146.0	253.0
200	4.1	8.2	14.8	29.7	43.7	81.2	126.5	219.0
300	3.3	6.7	12.3	24.3	35.5	66.2	105.0	178.5
RELIEF DEVICE SET AT 300 PSIA (P ₁)								
50	9.7	19.8	35.7	71.4	104.5	195.0	303.6	525.6
75	7.9	16.2	29.1	58.3	85.8	159.0	250.8	429.0
100	6.9	13.9	25.4	50.4	73.9	137.7	216.0	370.8
150	5.6	11.3	20.7	41.1	60.0	112.2	175.2	303.6
200	4.9	9.8	17.8	35.6	52.4	97.4	151.8	262.8
300	3.9	7.9	14.7	29.1	42.6	79.4	126.0	214.2

(5) **POSITIVE DISPLACEMENT COMPRESSOR PROTECTION.** Every Group 1 refrigerant positive displacement compressor operating above 15 psig and having a displacement exceeding 50 cfm, and every Group 2 or Group 3 refrigerant positive displacement compressor, shall be equipped by the manufacturer with a pressure-relief device of adequate size and pressure setting to prevent rupture of the compressor, located between the compressor and stop valve on the discharge side. The pressure-relief device shall discharge into the low pressure side of the system, or to the atmosphere at a location not less than 15 feet above the adjoining ground level and not less than 20 feet from any window, ventilator opening, or entrance of any building.

History: Cr. Register, September, 1983, No. 333, eff. 10-1-83.

ILHR 45.23 Installation requirements. (1) **FOUNDATIONS.** Foundations and supports for condensing units or compressor units shall be of substantial and noncombustible construction when more than 6 inches high.

(2) **GUARDING.** Moving machinery shall be guarded in accordance with chs. Ind 1000 to 2000.

(3) **ACCESS.** Clear space for inspection and servicing of condensing units or compressor units shall be provided.

(4) **ENCLOSURES.** Condensing units or compressor units with enclosures shall be accessible for servicing and inspection.

(5) **WATER SUPPLY AND DISCHARGE.** Water supply and discharge connections shall be made in accordance with the Wisconsin state uniform plumbing code, chs. ILHR 81 to 85.

(6) **ILLUMINATION.** Illumination for inspection and servicing of condensing units or compressor units shall be provided in accordance with ch. Ind 19.

(7) **ELECTRICAL.** Electrical equipment and wiring shall be installed in accordance with the Wisconsin state electrical code, volume 2, ch. ILHR 16.

(8) **GAS DEVICES.** Gas fuel devices and equipment used with refrigerating systems shall be installed in accordance with ch. Ind 64.

(9) AIR DUCTS. (a) Air duct systems of air-conditioning equipment for human comfort using mechanical refrigeration shall be installed in accordance with ss. Ind 64.31 to 64.44.

(b) Air ducts passing through a Class T machinery room shall be of tight construction and shall have no openings in such rooms.

(10) JOINTS IN AIR DUCTS. Joints and all refrigerant-containing parts of a refrigerating system located in an air duct carrying conditioned air to and from a humanly occupied space shall be constructed to withstand a temperature of 700° F. without leakage into the air stream.

(11) LOCATION OF REFRIGERANT PIPING. (a) Refrigerant piping crossing an open space which affords passageway in any building shall be not less than 7-1/2 feet above the floor unless against the ceiling of such space.

(b) Free passageway shall not be obstructed by refrigerant piping. Refrigerant piping shall not be placed in any elevator, dumbwaiter, or other shaft containing a moving object, or in any shaft which has openings to living quarters or to main exit hallways. Refrigerant piping shall not be placed in public hallways, lobbies, or stairways, except that such refrigerant piping may pass across a public hallway, if there are no joints in the section in the public hallway, and provided nonferrous tubing of 1-1/8 inch outside diameter and smaller be contained in a rigid metal pipe.

(c) Except as provided in subds. 1., 2. and 3, refrigerant piping shall not be installed vertically through floors from one story to another.

1. Refrigerant piping may be installed from the basement to the first floor, from the top floor to a machinery penthouse or to the roof, or between adjacent floors served by the refrigerating system.

2. For the purpose of interconnecting separate pieces of equipment not located as described in subd. 1., the piping may be carried in an approved rigid and tight continuous fire-resisting pipe duct or shaft having no openings into floors not served by the refrigerating system or it may be carried on the outer wall of the building provided it is not located in an air shaft, closed court or in other similar spaces enclosed within the outer walls of the building. The pipe duct or shaft shall be vented to the outside.

3. Piping of direct systems containing Group 1 refrigerants as governed by s. ILHR 45.18 (7), need not be enclosed where it passes through space served by that system.

(d) Refrigerant piping may be installed horizontally in closed floors or in open joist spaces. Piping installed in concrete floors shall be encased in pipe duct.

(12) MACHINERY ROOM REQUIREMENTS. (a) Each refrigerating machinery room shall be provided with a tight-fitting door or doors and have no partitions or openings that will permit the passage of escaping refrigerant to other parts of the building.

(b) Each refrigerating machinery room shall be provided with means for ventilation to the outer air. The ventilation shall consist of windows or doors opening to the outer air, of the size shown in Table 45.23, or of mechanical means capable of removing the air from the room in accord-

ance with Table 45.23. The amount of ventilation for refrigerant removal purposes shall be determined by the refrigerant content of the largest system in the machinery room.

(c) Air supply and return ducts used for machinery room ventilation shall serve no other area.

(d) Mechanical ventilation, when used, shall consist of one or more power-driven exhaust fans, which shall be capable of removing from the refrigerating machinery room the amount of air specified in Table 45.23. The inlet to the fan, or fans, or air duct connection shall be located near the refrigerating equipment. The outlet from the fan, or fans, or air duct connections shall terminate outside of the building in an approved manner. When air ducts are used either on the inlet or discharge side of the fan, or fans, they shall have an area not less than specified in Table 45.23. Provision shall be made for the inlet of air to replace that being exhausted.

(e) A Class T machinery room means a machinery room having no flame-producing apparatus permanently installed and operated, and also conforming to subs. 1. to 8.

1. Any doors, communicating with the building, shall be approved self-closing, tight-fitting fire door assemblies with at least a 3/4-hour fire-rating.

2. Walls, floor, and ceiling shall be tight and of not less than one-hour fire-resistive construction.

3. A Class T machinery room shall have an exit door which opens directly to the outer air or through a vestibule-type exit equipped with self-closing, tight-fitting doors.

4. Exterior openings, if present, shall not be under any fire escape or any open stairway.

5. All pipes piercing the interior walls, ceiling, or floor of such room shall be tightly sealed to the walls, ceiling, or floor through which they pass.

Note: See s. Ind 51.049 for further explanatory information.

6. Emergency remote controls to stop the action of the refrigerant compressor shall be provided and located immediately outside the machinery room.

7. An independent mechanical ventilation system shall be provided. Where Class T machinery rooms are located in basements or sub-basements, the ventilation system shall be operated continuously.

Note: See s. Ind 64.18 for further explanatory information.

8. Emergency remote controls for the mechanical means of ventilation shall be provided and located outside the machinery room.

Table 45.23
MINIMUM AIR DUCT AREAS AND OPENINGS

Weight of Refrigerant in System, Pounds	Mechanical Discharge of Air, cfm	Duct Area, Square Feet	Open Areas of Windows and Doors, Square Feet
up to 20	150	¼	4
50	250	¼	6
100	400	½	10
150	550	¾	12½
200	680	¾	14
250	800	1	15
300	900	1	17
400	1,100	1¼	20
500	1,275	1¼	22
600	1,450	1½	24
700	1,630	1½	26
800	1,800	2	28
900	1,950	2	30
1,000	2,050	2	31
1,250	2,250	2¼	33
1,500	2,500	2¼	37
1,750	2,700	2¼	38
2,000	2,900	2¼	40
2,500	3,300	2½	43
3,000	3,700	3	48
4,000	4,600	3¾	55
5,000	5,500	4½	62
6,000	6,300	5	68
7,000	7,200	5½	74
8,000	8,000	5¾	80
9,000	8,700	6¼	85
10,000	9,500	6½	90
12,000	10,900	7	100
14,000	12,200	7½	109
16,000	13,300	7¾	118
18,000	14,300	8	125
20,000	15,200	8¼	130
25,000	17,000	8¾	140
30,000	18,200	9	145
35,000	19,400	9¼	150
40,000	20,500	9½	155
45,000	21,500	9¾	160

History: Cr. Register, September, 1983, No. 333, eff. 10-1-83.

ILHR 45.24 Field tests. (1) GENERAL. Every refrigerant-containing part of every system that is erected on the premises, except compressors, condensers, evaporators, safety devices, pressure gages, control mechanisms and systems that are factory tested, shall be tested and proved tight after complete installation, and before operation.

(a) Except as provided in par. (b), the high and low side of each system shall be tested and proved tight at not less than the lower of the design pressure or the setting of the pressure-relief device protecting the high or low side of the system, respectively.

(b) Systems erected on the premises containing Group 1 refrigerant and with copper tubing not exceeding 5/8-inch outside diameter may be tested by means of the refrigerant charged into the system at the saturated vapor pressure of the refrigerant at 70° F. minimum.

(2) TEST MEDIUM. (a) Oxygen or any combustible gas or combustible mixture of gases shall not be used within the system for testing.

(b) The means used to build up the test pressure shall have either a pressure-limiting device or a pressure-reducing device with a pressure-relief device and a gage on the outlet side. The pressure-relief device shall be set above the test pressure but low enough to prevent permanent deformation of the system components.

Note: A dated declaration of test should be provided for all systems containing 50 pounds or more of refrigerant. The declaration should give the name of the refrigerant and the field test pressure applied to the high side and the low side of the system. The declaration of test should be signed by the installer and, if an inspector is present at the tests, the inspector should also sign the declaration. When requested, copies of this declaration should be furnished to the department.

History: Cr. Register, September, 1983, No. 333, effective 9/1/83

ILHR 45.25 General requirements. (1) SIGNS. (a) Each refrigerating system erected on the premises shall be provided with a legible permanent sign securely attached and accessible, indicating thereon the name and address of the installer, the kind and total number of pounds of refrigerant required in the system for normal operations, and the field test pressure applied.

(b) Systems containing more than 100 pounds of refrigerant shall be provided with metal signs having letters not less than 1/2 inches in height designating the main shut-off valves to each vessel, main steam or electric control, remote control switch, and pressure-limiting device. On all exposed high pressure and low pressure piping in each room where installed outside the machinery room, shall be signs, as specified above, with the name of the refrigerant and the letters H.P. or L.P.

(c) When the kind of refrigerant is changed as provided in sub. (2), there shall be a new sign, of the same type as specified in par. (b), indicating clearly that a substitution has been made and stating the same information for the new refrigerant as was stated in the original.

(2) SUBSTITUTION OF REFRIGERANT. Substitution of kind of refrigerant in a system shall not be made without the permission of the department, the user, and the makers of the original equipment, and due observance of safety requirements.

(3) CHARGING AND DISCHARGING. When refrigerant is added to a system, except a unit system requiring less than 6 pounds of refrigerant, it shall be charged into the low pressure side of the system. Any point on the downstream side of the main liquid line stop valve shall be considered as part of the low pressure side when operating with said stop valve in the closed position. No service container may be left connected to a system except while charging or withdrawing refrigerant.

(4) WITHDRAWN REFRIGERANTS. Refrigerants withdrawn from refrigerating systems shall be transferred to approved containers only. No refrigerant may be discharged to a sewer.

(5) REFRIGERANT CONTAINERS. Containers used for refrigerants withdrawn from a refrigerating system shall be carefully weighed each time they are used for this purpose, and the containers shall not be filled in excess of the permissible filling weight for such containers and such refrigerants.

(6) **STORAGE OF REFRIGERANTS.** Refrigerant stored in a machinery room shall be not more than 300 pounds, in addition to the charge in the system and the refrigerant stored in a permanently attached receiver, and then only in approved storage containers.

(7) **MASKS OR HELMETS.** At least two masks or helmets shall be provided at a location convenient to the machinery room when an amount of a Group 2 refrigerant exceeds 100 pounds.

(a) Only complete helmets or masks marked as approved by the department and suitable for the refrigerant employed shall be used and they shall be kept in a suitable cabinet immediately outside the machinery room or other approved accessible location.

Note: Helmets and masks approved by the Bureau of Mines of the United States Department of the Interior will be acceptable.

(b) Canisters or cartridges of helmets or masks shall be renewed immediately after having been used or the seal broken and, if unused, the canisters shall be renewed not later than the date noted on the canister labels.

(8) **MAINTENANCE.** All refrigerating systems shall be maintained by the user in a clean condition, free from accumulations of oily dirt, waste and other debris, and shall be kept readily accessible at all times.

(9) **DIRECTIONS FOR OPERATION.** The person in charge of the premises on which a refrigerating system containing more than 50 pounds of refrigerant is installed, shall place a card conspicuously as near as practicable to the refrigerant compressor giving directions for the operation of the system, including precautions to be observed in case of a breakdown or leak as specified in pars. (a) to (c).

(a) Instruction for shutting down the system in case of emergency;

(b) The name, address, and day and night telephone numbers for obtaining service; and

(c) The name, address, and telephone number of the municipal inspection department having jurisdiction, and instructions to notify said department immediately in case of emergency.

(10) **PRESSURE GAGE ACCURACY.** Pressure gages shall be checked for accuracy prior to test and immediately after every occasion of unusually high pressure, equal to full scale reading either by comparison with master gages or by setting the pointer as determined by a dead weight pressure gage tester.

History: Cr. Register, September, 1983, No. 333, eff. 10-1-83.

APPENDIX

The material contained in this appendix is for clarification purposes only. The explanations and illustrations are numbered to correspond to the number of the rule as it appears in the text of the chapter.

A 45.07 (2) Forms. The following form (SB-34) is referred to in s. ILHR 45.07. Copies are available from the Division of Safety and Buildings, P.O. Box 7969, Madison, Wisconsin 53707.

State of Wisconsin
 Department of Industry, Labor & Human Relations
SAFETY AND BUILDINGS DIVISION

**MECHANICAL REFRIGERATION
 INSTALLATION REGISTRATION**

Complete appropriate portion

Installing Contractor shall prepare this form in triplicate and distribute as follows:

- White - Attach Registration Fee of \$16.00 making check payable to Wisconsin Department of Industry, Labor & Human Relations. Send to Safety & Buildings Division, Box 7969, Madison, Wisconsin 53707.
- Yellow - Send to Owner who shall POST IT IN A CONSPICUOUS PLACE.
- Pink - Retain for file

<p>REFRIGERATION SYSTEMS</p> <p>TYPE <input type="checkbox"/> Self contained <input type="checkbox"/> Direct <input type="checkbox"/> Indirect</p> <p>USE <input type="checkbox"/> Air Cond <input type="checkbox"/> Mfg. or Storage <input type="checkbox"/> Rect</p> <p>CAPACITY Tons _____ KVA _____ HP _____ Refrigerant _____ Pounds in system _____ Saturated _____</p> <p>DISTRIBUTION PIPING <input type="checkbox"/> Steel <input type="checkbox"/> Copper <input type="checkbox"/> Other _____</p> <p>CONNECTIONS <input type="checkbox"/> Welded <input type="checkbox"/> Braided <input type="checkbox"/> Soldered <input type="checkbox"/> Threaded</p> <p>City _____ State _____ Name of Installing Contractor _____ Date Installation Completed _____</p>	<p>Street Address _____ City _____ State _____ Zip _____ Name of Installing Contractor _____ Street Address _____ Date Installation Completed _____ Signature of Installer _____ Date Registered _____</p>
---	--