

## Chapter Comm 81

## DEFINITIONS AND STANDARDS

Comm 81.01 Definitions.

Comm 81.20 Incorporation of standards by reference.

**Comm 81.01 Definitions.** In chs. Comm 81 to 87, except as otherwise specifically defined:

(1) "Accepted engineering practice" means a specification, standard, guideline or procedure in the field of plumbing or related thereto, generally recognized and accepted as authoritative documented through national standards or specifications.

(2) "Accessible" when applied to a fixture, appliance, pipe, fitting, valve or equipment, means having access for maintenance, but which first may require the removal of an access panel or similar obstruction.

(2m) "Accessory building" means a detached building, not used as a dwelling unit but is incidental to that of the dwelling.

(3) "Aerobic treatment component" means a unit for the treatment of wastewater that utilizes the principle of oxidation for biological decomposition.

(4) "Agent" means an individual or agency recognized by the department to act on the department's behalf relative to a specific activity or function.

(5) "Air-break" means a piping arrangement for a drain system where the wastes from a fixture, appliance, appurtenance or device discharge by means of indirect or local waste piping terminating in a receptor at a point below the flood level rim of the receptor and above the inlet of the trap serving the receptor.

(6) "Air-gap, drain system" means the unobstructed vertical distance through the free atmosphere between the outlet of indirect or local waste piping and the flood level rim of the receptor into which it discharges.

(7) "Air-gap, water supply system" means the unobstructed vertical distance through the free atmosphere between the lowest opening from any pipe or faucet supplying water to a tank or plumbing fixture and the flood level rim or spill level of the receptacle.

(7e) "Alternate plumbing system" means a type of plumbing system designed in such a manner that valid and reliable data shall demonstrate to the department that the plumbing system is in compliance with the intent of chs. Comm 81 to 84.

(7m) "Ambulatory surgery center" means a health care facility that accepts federal funding in accordance with 42 CFR 416 of the federal register for health care finance and where 4 or more individuals that undergo a surgical procedure for which federal reimbursement is based.

(8) "Anaerobic treatment component" means a unit for the treatment of wastewater which utilizes molecular oxygen in the absence of free oxygen for biological respiration and decomposition.

(9) "Approved" means acceptance documented in writing by the department.

(10) "Appurtenance" means a manufactured device or prefabricated assembly of component parts which is an adjunct to a plumbing product or plumbing system.

(11) "Area drain" means a receptor designed to collect storm waters from an open area.

(12) "Areawide water quality management plan" means those plans prepared by the department of natural resources, including those plans prepared by agencies designated by the governor under the authority of ss. 281.11, 281.12 (1), 281.15, and 283.83,

Stats., for the purpose of managing, protecting and enhancing groundwater and surface water of the state.

Note: See ch. Comm 82 Appendix for a list of water quality management agencies and their addresses.

(13) "Aspirator" means a fitting or device supplied with water or other fluid under positive pressure which passes through an integral orifice or constriction causing a vacuum.

(14) "Autopsy table" means a fixture or table used for post-mortem examination.

(15) "Automatic fire sprinkler system" has the meaning specified under s. 145.01 (2), Stats.

Note: Section 145.01 (2), Stats., reads: "Automatic fire sprinkler system", for fire protection purposes, means an integrated system of underground and overhead piping designed in accordance with fire protection engineering standards. The system includes a suitable water supply, such as a gravity tank, fire pump, reservoir or pressure tank or connection beginning at the supply side of an approved gate valve located at or near the property line where the pipe or piping system provides water used exclusively for fire protection and related appurtenances and to standpipes connected to automatic sprinkler systems. The portion of the sprinkler system above ground is a network of specially sized or hydraulically designed piping installed in a building, structure or area, generally overhead, and to which sprinklers are connected in a systematic pattern. The system includes a controlling valve and a device for actuating an alarm when the system is in operation. The system is usually activated by heat from a fire and discharges water over the fire area.

(16) "Backflow" means the unwanted reverse flow of liquids, solids or gases.

(17) "Back pressure" means a pressure greater than the supply pressure that may cause backflow.

(17e) "Backflow preventer" means any generic backflow prevention device or assembly.

(18) "Backflow preventer with intermediate atmospheric vent" means a type of cross connection control device which consists of 2 independently acting check valves, internally force-loaded to a normally closed position and separated by an intermediate chamber with a means for automatically venting to atmosphere where the venting means is internally force-loaded to a normally open position. The terms "backflow preventer" or "dual check valve type with atmospheric port backflow preventer" has the same meaning as backflow preventer with intermediate atmospheric vent.

(19) "Back siphonage" means the creation of a backflow as a result of negative pressure.

(20) "Back siphonage backflow vacuum breaker" means a type of cross connection control device which contains a check valve force-loaded closed and an air inlet vent valve force-loaded open to atmosphere, positioned downstream of the check valve, and located between and including 2 tightly closing shut-off valves and 2 test cocks. The term "SVB" has the same meaning as back siphonage backflow vacuum breaker.

(21) "Backwater valve" means a device designed to prevent the reverse flow of wastewater in a drain system.

(22) "Ballcock" means a water supply valve opened or closed by means of a float or similar device used to supply water to a tank.

(23) "Bathroom group" means a water closet, lavatory and a bathtub or shower located together on the same floor level.

(24) "Battery of fixtures" means any group of 2 or more fixtures that discharge into the same horizontal branch drain.

(25) "Bedpan sterilizer" means a fixture used for sterilizing bedpans or urinals by direct application of steam, boiling water or chemicals.

(26) "Bedpan washer and sanitizer" means a fixture designed to wash bedpans and to flush the contents into the sanitary drain system and which may also provide for disinfecting utensils by scalding with steam or hot water.

(27) "Bedpan washer hose" means a device supplied with hot or cold water, or both, and located adjacent to a water closet or clinical sink to be used for cleansing bedpans.

(28) "Bedrock" means rock that is exposed at the earth's surface or underlies soil material and includes:

(a) Weathered in-place consolidated material, larger than 2 mm in size and greater than 50% by volume; and

(b) Weakly consolidated sandstone at the point of increased resistance to penetration of a knife blade.

(29) "Bell" means the portion of a pipe that is enlarged to receive the end of another pipe of the same diameter for the purpose of making a joint.

(30) "Bench mark" or "BM" means a permanently established point, the elevation of which is assumed or known, which serves as a vertical reference point, and which may also serve as a horizontal reference point.

(31) "Blackwater" means wastewater contaminated by human body waste, toilet paper and any other material intended to be deposited in a receptor designed to receive urine or feces.

(32) "BOD<sub>5</sub>" or "biochemical oxygen demand 5 day" means a measure of the amount of biodegradable organic matter in water.

(33) "Boiler blow-off basin" means a vessel designed to receive the discharge from a boiler blow-off outlet and to cool the discharge to a temperature that permits safe entry into the drain system.

(34) "Branch" means a part of a piping system other than a riser, main or stack.

(35) "Branch interval" means the vertical distance along a drain stack measured from immediately below a branch drain connection to immediately below the first lower branch drain connection that is 8 feet or more below.

Note: See ch. Comm 82 Appendix for an illustration depicting branch intervals.

(35m) "Branch tailpiece" means a fitting consisting of a combination tail piece and a wye.

(36) "Branch vent" means a vent serving more than one fixture drain.

(37) "B.T.U." means British Thermal Units.

(38) "Building" means a structure for support, shelter or enclosure of persons or property.

(39) "Building drain" means horizontal piping within or under a building, installed below the lowest fixture or the lowest floor level from which fixtures can drain by gravity to the building sewer.

(40) "Building drain branch" means a fixture drain which is individually connected to a building drain and is vented by means of a combination drain and vent system.

(41) "Building drain, sanitary" means a building drain which conveys wastewater consisting in part of domestic wastewater.

(42) "Building drain, storm" means a building drain which conveys storm water, clear water, or both.

(43) "Building permit" means any written permission from a municipality that allows construction to commence on a structure.

(44) "Building sewer" means that part of the drain system not within or under a building which conveys its discharge to a public sewer, private interceptor main sewer, private onsite wastewater treatment system or other point of discharge or dispersal.

(45) "Building sewer, sanitary" means a building sewer which conveys wastewater consisting in part of domestic wastewater.

(46) "Building sewer, storm" means a building sewer which conveys storm water, clear water, or both.

(47) "Building subdrain" means the horizontal portion of a drain system which does not flow by gravity to the building sewer.

(48) "Building subdrain branch" means a fixture drain which is individually connected to a building subdrain and is vented by means of a combination drain and vent system.

(49) "Burr" means a roughness or metal protruding from the walls of a pipe usually as the result of cutting the pipe.

(50) "Business establishment" means any industrial or commercial organization or enterprise operated for profit, including but not limited to a proprietorship, partnership, firm, business trust, joint venture, syndicate, corporation or association.

(51) "Camping unit transfer container" means a type of stationary holding tank used to collect and hold wastewater discharges generated by an individual camping trailer or recreational vehicle.

(51m) "Campsite receptor" means the vertical drain piping and trap combination that receives wastewater from recreational vehicles.

(52) "Catch basin" means a watertight receptacle built to arrest sediment of surface, subsoil or other waste drainage, and to retain oily or greasy wastes, so as to prevent their entrance into the building drain or building sewer.

(53) "Cesspool" means an excavation which receives domestic wastewater by means of a drain system without pretreatment of the wastewater and retains the organic matter and solids permitting the liquids to seep from the excavation.

(54) "Circuit vent" means a method of venting 2 to 8 traps or trapped fixtures without providing an individual vent for each trap or fixture.

(55) "Cleanout" means an accessible opening in a drain system used for the removal of obstructions.

(56) "Clear water" means wastewater other than storm water, having no impurities or where impurities are below a minimum concentration considered harmful by the department, including but not limited to noncontact cooling water and condensate drainage from refrigeration compressors and air conditioning equipment, drainage of water used for equipment chilling purposes and cooled condensate from steam heating systems or other equipment.

(56e) "Clinic sink" means a fixture having an integral trap and a flushing rim so that water cleanses the interior surface.

Note: This fixture has flushing and cleansing characteristics similar to a water closet. A clinic sink may also be referred to as a clinic service sink, a bedpan washing sink or a flushing rim sink.

(57) "Cold water" means water at a temperature less than 85°F.

(58) "Combination fixture" means a fixture combining one sink and laundry tray or a 2- or 3-compartment sink or laundry tray in one unit.

(59) "Combination drain and vent system" means a specially designed system of drain piping embodying the wet venting of one or more fixtures by means of a common drain and vent pipe adequately sized to provide free movement of air in the piping.

(60) "Common vent" means a branch vent connecting at or downstream from the junction of 2 fixture drains and serving as a vent for those fixture drains.

(60e) "Community-based residential facility" has the meaning specified under s. 50.01 (1g), Stats.

Note: Section 50.01 (1g), Stats., reads: "Community-based residential facility" means a place where 5 or more adults who are not related to the operator or administrator and who do not require care above intermediate level nursing care reside and receive care, treatment or services that are above the level of room and board but that include no more than 3 hours of nursing care per week per resident. "Community-based residential facility" does not include any of the following:

(a) A convent or facility owned or operated by members of a religious order exclusively for the reception and care or treatment of members of that order.

(b) A facility or private home that provides care, treatment and services only for victims of domestic abuse, as defined in s. 46.95 (1) (a), Stats., and their children.

(c) A shelter facility as defined under s. 560.9808 (1) (d), Stats.

(d) A place that provides lodging for individuals and in which all of the following conditions are met:

1. Each lodged individual is able to exit the place under emergency conditions without the assistance of another individual.

2. No lodged individual receives from the owner, manager or operator of the place or the owner's, manager's or operator's agent or employee any of the following:

- a. Personal care, supervision or treatment, or management, control or supervision of prescription medications.
- b. Care or services other than board, information, referral, advocacy or job guidance; location and coordination of social services by an agency that is not affiliated with the owner, manager or operator, for which arrangements were made for an individual before he or she lodged in the place; or, in the case of an emergency, arrangement for the provision of health care or social services by an agency that is not affiliated with the owner, manager or operator.
- (e) An adult family home.
- (f) A residential care apartment complex.

(g) A residential facility in the village of Union Grove that was authorized to operate without a license under a final judgment entered by a court before January 1, 1982, and that continues to comply with the judgment notwithstanding the expiration of the judgment.

**(61)** "Conductor" means a drain pipe inside the building which conveys storm water from a roof to the storm drain or storm sewer.

**(61m)** "Containment" means the installation of a cross connection control method, device or assembly to prohibit the flow of contamination from a building or facility into a water supply system.

**(62)** "Contaminant load" means the concentrations of substances in a wastewater stream.

**(62m)** "Continuous pressure" means a pressure greater than atmospheric and exerted for a period of more than 12 continuous hours.

**(63)** "Corporation cock" means a valve:

- (a) Installed in a private water main or a water service at or near the connection to a public water main; or
- (b) Installed in the side of a forced main sewer to which a forced building sewer is connected.

**(64)** "Critical level" means the reference point on a vacuum breaker that must be submerged before backflow can occur. When the critical level is not indicated on the vacuum breaker, the bottom of the vacuum breaker shall be considered the critical level.

**(65)** "Cross connection" means a connection or potential connection between any part of a water supply system and another environment containing substances in a manner that, under any circumstances, would allow the substances to enter the water supply system by means of back siphonage or back pressure.

**(65m)** "Cross connection control assembly" means a testable backflow preventer consisting of an arrangement of components.

**(66)** "Cross connection control device" means any mechanical device which automatically prevents backflow from a contaminated source into a potable water supply system.

**(67)** "Curb stop" means a valve placed in a water service or a private water main, usually near the lot line.

**(67e)** "DC detector" has the same meaning as specified in sub. (80).

**(67m)** "DCV detector" has the same meaning as specified in sub. (79).

**(68)** "Dead end" means a branch leading from a drain pipe, vent pipe, building drain or building sewer and terminating at a developed length of 2 feet or more by means of a plug, cap or other closed fitting.

**(69)** "Department" means the department of commerce.

**(70)** "Design wastewater flow" means 150% of the estimated wastewater flow generated by a dwelling, building or facility.

**(71)** "Determination of failure" has the meaning specified under s. 145.245 (1) (a), Stats.

Note: Section 145.245 (1) (a), Stats., reads:

"Determination of failure" means any of the following:

1. A determination that a private sewage system is failing, according to the criteria under sub. (4), based on an inspection of the private sewage system by an employee of the state or a governmental unit who is certified to inspect private sewage systems by the department.
2. A written enforcement order issued under s. 145.02 (3) (f), 145.20 (2) (f) or 281.19 (2).
3. A written enforcement order issued under s. 254.59 (1) by a governmental unit.

**(72)** "Developed length" means the length of pipe line measured along the centerline of the pipe and fittings.

**(72e)** "Dfu" means drainage fixture unit.

**(73)** "Diameter" means in reference to a pipe the nominal inside diameter of the pipe.

**(74)** "Disinfection unit" means a type of POWTS treatment component, excluding a soil-based POWTS treatment component, that utilizes a chemical or photoelectric process to reduce the wastewater fecal coliform contaminant load.

**(75)** "Dispersal zone" means a dimensional volume of in situ soil that receives wastewater for treatment or distributes final effluent for dispersal.

**(76)** "Distribution cell" means a dimensional zone that is part of a POWTS treatment or dispersal component where wastewater is disseminated into in situ soil or engineered soil.

**(77)** "Documented data" means data which is developed in accordance with scientifically valid analytical protocols including field trials where appropriate, is subjected to peer review, results from more than one study, and consistent with other credible research.

**(78)** "Domestic wastewater" means the type of wastewater, not including storm water, normally discharged from or similar to that discharged from plumbing fixtures, appliances and devices including, but not limited to sanitary, bath, laundry, dishwashing, garbage disposal and cleaning wastewaters.

**(79)** "Double check backflow prevention assembly" means a type of cross connection control device which is composed of 2 independently acting check valves internally force-loaded to a normally closed position, tightly closing shut-off valves located at each end of the assembly and fitted with test cocks. The terms "backflow preventer, double check valve type" or "DCV" have the same meaning as double check backflow prevention assembly.

**(80)** "Double check detector assembly backflow preventer" means a type of a double check backflow prevention assembly which includes a parallel flow meter to indicate leakage or unauthorized use of water downstream of the assembly. The terms "DC detector" and "double check detector valve type backflow preventer" have the same meaning as double check detector backflow preventer.

Note: Downspout, see "leader".

**(81)** "Drain" means any pipe that carries wastewater or water-borne wastes.

**(82)** "Drain system" includes all the piping or any portion of the piping within public or private premises which conveys wastewater to a legal point of disposal, but does not include the mains of public sewer systems or a private onsite wastewater treatment system or public sewage treatment or disposal plant.

**(82m)** "Dual check valve type with atmospheric port backflow preventer" has the same meaning as specified in sub. (18).

**(83)** "Dwelling" means a structure, or that part of a structure, which is used or intended to be used as a home, residence or sleeping place by one person or by 2 or more persons maintaining a common household, to the exclusion of all others.

**(84)** "Effluent" means liquid discharged from a process, device, appurtenance or piping system.

**(85)** "Ejector" means an automatically operated device to elevate wastewater by the use of air under higher than atmospheric pressure.

**(86)** "Elevation" or "EL" means the vertical distance from the datum to a point under investigation.

**(87)** "Enforcement standard" or "ES" has the meaning specified under s. 160.01 (2), Stats.

Note: Section 160.01 (2), Stats., reads:

"Enforcement standard" means a numerical value expressing the concentration of a substance in groundwater which is adopted under ss. 160.07 and 160.09.

**(88)** "Engineered soil" means a mineral product that is equivalent to in situ soil for which treatment capability has been credited under Table 83.44-3, or superior to in situ soil in its ability to treat or disperse domestic wastewater from a POWTS.

**(89)** "Engineered system" means a system designed to meet the intent of the code but not the enumerated specifications of the state plumbing code.

**(90)** "Estimated wastewater flow" means the typical quantity of domestic wastewater generated daily by a dwelling, building or facility.

**(90e)** "Experimental plumbing system" has the same meaning as experimental system as specified in sub. (91).

**(90m)** "Exam sink" means a plumbing fixture used for hand washing in health care and related facilities.

Note: An exam sink may also be referred to as a treatment sink.

**(91)** "Experimental system" means a type of plumbing system from which valid and reliable data are being sought to demonstrate compliance with the intent of chs. Comm 82 to 84.

**(92)** "Failing private onsite wastewater treatment system" has the meaning specified under s. 145.245 (4), Stats.

Note: Section 145.245 (4) reads:

"Failing private sewage system" means a private sewage system which causes or results in any of the following conditions:

- (a) The discharge of sewage into surface water or groundwater.
- (b) The introduction of sewage into zones of saturation which adversely affects the operation of a private sewage system.
- (c) The discharge of sewage to a drain tile or into zones of bedrock.
- (d) The discharge of sewage to the surface of the ground.
- (e) The failure to accept sewage discharges and backup of sewage into the structure served by the private sewage system.

**(93)** "Farm" means a parcel of 35 or more acres of contiguous land that is devoted primarily to agricultural use, as defined under s. 91.01 (1) and (5), Stats.

Note: Section 91.01 (1) and (5), Stats., read:

(1) "Agricultural use" means beekeeping; commercial feedlots; dairying; egg production; floricultural; fish or fur farming; forest and game management; grazing; livestock raising; orchards; plant greenhouses and nurseries; poultry raising; raising of grain, grass, mint and seed crops; raising of fruits, nuts and berries; sod farming; placing land in federal programs in return for payment in kind; owning land, at least 35 acres of which is enrolled in the conservation reserve program under 16 USC 3831 to 3836; participating in the milk production termination program under 7 USC 1446 (d); and vegetable raising.

(5) "Devoted primarily to agricultural use" means under agricultural use for at least 12 consecutive months during the preceding 36-month period.

**(94)** "Faucet" means a valve end of a water pipe by means of which water can be drawn from or held within the pipe.

**(95)** "Final effluent" means the effluent from the last POWTS treatment component.

**(96)** "Fixture drain" means the drain from a fixture to a junction with another drain pipe.

**(97)** "Fixture supply" means that portion of a water distribution system serving one plumbing fixture, appliance or piece of equipment.

**(98)** "Fixture supply connector" means that portion of water supply piping which connects a plumbing fixture, appliance or a piece of equipment to the water distribution system.

**(99)** "Fixture unit, drainage" or "dfu" means a measure of the probable discharge into the drain system by various types of plumbing fixtures. The drainage fixture unit value for a particular fixture depends on its volume rate of drainage discharge, on the time duration of a single drainage operation, and on the average time between successive operations.

**(100)** "Fixture unit, supply" or "sfu" means a measure of the probable hydraulic demand on the water supply by various types of plumbing fixtures.

Note: The supply fixture unit value for a particular fixture depends on its volume rate of supply, on the time duration of a single supply operation, and on the average time between successive operations.

**(101)** "Floodfringe" has the meaning specified under s. NR 116.03 (14).

Note: Section NR 116.03 (14) reads: "Floodfringe" means that portion of a flood plain which is outside of the floodway, which is covered by flood water during the

regional flood. The term "floodfringe" is generally associated with standing water rather than flowing water.

**(102)** "Flood level rim" means the edge of the receptacle from which water overflows.

**(103)** "Floodplain" has the meaning specified under s. NR 116.03 (16).

Note: Section NR 116.03 (16) reads:

"Floodplain" means that land which has been or may be covered by flood water during the regional flood. The floodplain includes the floodway, floodfringe, shallow depth flooding, flood storage and coastal floodplain areas.

**(104)** "Floodway" has the meaning specified under s. NR 116.03 (22).

Note: Section NR 116.03 (22) reads:

"Floodway" means the channel of a river or stream, and those portions of the flood plain adjoining the channel required to carry the regional flood discharge.

**(105)** "Floor sink" means a receptor for the discharge from indirect or local waste piping installed with its flood level rim even with the surrounding floor.

**(106)** "Flow" means the volumetric measure of a liquid stream in a specified time.

**(107)** "Flushometer valve" means a device which discharges a predetermined quantity of water to fixtures for flushing purposes and is closed by direct water pressure.

**(108)** "Flush valve" means a device located at the bottom of a tank for flushing water closets and similar fixtures.

**(108m)** "Foundation drain" means a subsoil drain that serves the area of the foundation of a building.

**(109)** "Garage, private" means a building or part of a building used for the storage of vehicles or other purposes, by a family or less than 3 persons not of the same family and which is not available for public use.

**(110)** "Garage, public" means a building or part of a building which accommodates or houses self-propelled land, air or water vehicles for 3 or more persons not of the same family.

**(111)** "Governmental unit" has the meaning specified under s. 145.01 (5), Stats.

Note: Section 145.01 (5), Stats., reads:

"Governmental unit responsible for the regulation of private sewage systems" or "governmental unit", unless otherwise qualified, means the county, except that in a county with a population of 500,000 or more these terms mean the city, village or town where the private sewage system is located.

**(112)** "Graywater" means wastewater contaminated by waste materials, exclusive of urine, feces or industrial waste, deposited into plumbing drain systems.

**(113)** "Grease interceptor" means a receptacle designed to intercept and retain or remove grease or fatty substances.

**(114)** "Groundwater" has the meaning specified under s. 160.01 (4), Stats.

Note: Section 160.01 (4), Stats., reads:

"Groundwater" means any of the waters of the state, as defined under s. 281.01 (18), occurring in a saturated subsurface geological formation of rock or soil.

**(115)** "Hand-held shower" means a type of plumbing fixture that includes a cross connection control device, a hose and a hand-held discharge piece such as a shower head or spray.

**(116)** "Health care and related facility" means a hospital, nursing home, community-based residential facility, county home, infirmary, inpatient mental health center, inpatient hospice, ambulatory surgery center, adult daycare center, end stage renal facility, facility for the developmentally disabled, institute for mental disease, urgent care center, clinic or medical office, child caring institution, or school of medicine, surgery or dentistry.

**(117)** "Health care plumbing appliance" means a plumbing appliance, the function of which is unique to health care activities.

**(118)** "High groundwater" means zones of soil saturation which include perched water tables, shallow regional groundwater tables or aquifers, or zones that are seasonally, periodically or permanently saturated.

**(119)** "High groundwater elevation" means the higher of either the elevation to which the soil is saturated when observed as a free water surface, or the elevation to which the soil has been

seasonally or periodically saturated as indicated by the highest elevation of redoximorphic features in the soil profile.

**(120)** "High hazard" means a situation where the water supply system could be contaminated with a toxic solution so as to alter the characteristics of the water making the water unsuitable for the designated use.

**(121)** "Holding tank" means a watertight receptacle for the collection and holding of wastewater.

**(122)** "Horizontal pipe" means any pipe or fitting which makes an angle of less than 45° with the horizontal.

**(123)** "Horizontal reference point" means a stationary, identifiable point to which horizontal dimensions can be related.

**(124)** "Hose connection backflow preventer" means a type of cross connection control device which consists of 2 independent checks, force-loaded or biased to a closed position, with an atmospheric vent located between the 2 check valves, which is force-loaded or biased to an open position, and a means for attaching a hose.

**(125)** "Hose connection vacuum breaker" means a type of cross connection control device which consists of a check valve member force-loaded or biased to a closed position and an atmospheric vent valve or means force-loaded or biased to an open position when the device is not under pressure.

**(126)** "Hot water" means water at a temperature of 110° F. or more.

**(127)** "Hot water storage tank" means a tank used to store water that is heated indirectly by a circulating water heater or by steam or hot water circulating through coils or by other heat exchange methods internal or external to the tank.

**(128)** "Human health hazard" has the meaning specified under s. 254.01 (2), Stats.

Note: Section 254.01 (2), Stats., reads:

"Human health hazard" means a substance, activity or condition that is known to have the potential to cause acute or chronic illness or death if exposure to the substance, activity or condition is not abated.

**(129)** "Hydrostatic test" means a test performed on a plumbing system or portion thereof in which the system is filled with a liquid, normally water, and raised to a designated pressure.

**(130)** "Indian lands" means lands owned by the United States and held for the use or benefit of Indian tribes or bands or individual Indians, and lands within the boundaries of a federally recognized reservation that are owned by Indian tribes or bands or individual Indians.

**(131)** "Indirect waste piping" means drain piping which does not connect directly with the drain system, but which discharges into the drain system by means of an air break or air gap into a receptor.

**(132)** "Individual vent" means a pipe installed to vent a fixture trap.

**(133)** "Industrial wastewater" means the liquid wastes that result from industrial processes.

**(134)** "Infiltrative surface" means the plane within a treatment or dispersal component at which effluent is applied to in situ soil or engineered soil.

**(135)** "In situ soil" means soil naturally formed or deposited in its present location or position and includes soil material that has been plowed using normal tillage implements and depositional material resulting from erosion or flooding.

**(136)** "Interceptor" or "separator" means a device designed and installed so as to separate and retain deleterious, hazardous or undesirable matter from wastes flowing through it.

**(137)** "Laboratory faucet backflow preventer" means a type of cross connection control device which consists of 2 independently acting check valves force-loaded or biased to a closed position and, between the check valves, a means for automatically venting to atmosphere which is force-loaded or biased to an open position.

**(138)** "Laboratory plumbing appliance" means a plumbing appliance, the function of which is unique to scientific experimentation or research activities.

**(139)** "Leaching chamber" means a product designed to support soil and create a cavity for the temporary storage of effluent and to provide an infiltrative surface for the distribution cell POWTS dispersal or treatment component.

**(140)** "Leader" means a pipe or channel outside a building which conveys storm water from the roof or gutter drains to a storm drain, storm sewer or to grade.

**(141)** "Lead-free" means a chemical composition equal to or less than 0.2% of lead.

**(142)** "Linear loading rate" means the amount of effluent applied daily along the landscape contour expressed in gallons per day per linear foot along a site contour.

**(143)** "Load factor" means the percentage of the total connected fixture unit flow rate which is likely to occur at any point in a drain system.

**(144)** "Local station" means a National Weather Service (NWS) precipitation station or other station accepted by the department as collecting precipitation data in accordance with NWS methods.

**(145)** "Local waste piping" means a portion of drain piping which receives the wastes discharged from indirect waste piping and which discharges those wastes by means of an air break or air gap into a receptor.

**(146)** "Local vent" means a pipe connecting to a fixture and extending to outside air through which vapor or foul air is removed from the fixture.

**(147)** "Low hazard" means a situation where the water supply system could be contaminated with a nontoxic substance so as to alter the characteristics of the water making the water unsuitable for the designated use.

**(148)** "Main" means the principal pipe artery to which branches may be connected.

**(149)** "Manhole" means an opening constructed to permit access by a person to a sewer or any underground portion of a plumbing system.

**(150)** "Manufactured dwelling" has the meaning specified under s. Comm 20.07 (52) (a).

Note: Section Comm 20.07 (52) (a) reads:

"Manufactured dwelling" means any structure or component thereof which is intended for use as a dwelling and:

1. Is of closed construction and fabricated or assembled on site or off site in manufacturing facilities for installation, connection or assembly and installation at the building site; or

2. Is a building of open construction which is made or assembled in manufacturing facilities away from the building site for installation, connection or assembly and installation on the building site and for which certification is sought by the manufacturer.

**(151)** "Mechanical joint" means a connection between pipes, fittings or pipes and fittings by means of a device, coupling, fitting or adapter where compression is applied around the center line of the pieces being joined, but which is not caulked, threaded, soldered, solvent cemented, brazed or welded.

**(152)** "Mobile home" means a vehicle as defined under s. 66.0435 (1) (d), Stats.

Note: Section 66.0435 (1) (d), Stats., reads:

"Mobile home" is that which is, or was as originally constructed, designed to be transported by any motor vehicle upon a public highway and designed, equipped and used primarily for sleeping, eating and living quarters, or is intended to be so used; and includes any additions, attachments, annexes, foundations and appurtenances.

**(153)** "Mobile home drain connector" means the pipe that joins the drain piping for a mobile or manufactured home to the building sewer.

**(154)** "Mobile home park" has the meaning specified under s. 66.0435 (1) (e), Stats.

Note: Section 66.0435 (1) (e), Stats., reads:

"Mobile home park" means any plot or plots of ground upon which 2 or more units, occupied for dwelling or sleeping purposes are located, regardless of whether or not a charge is made for such accommodation.

**(155)** "Multiple dwelling" means a building containing more than 2 dwelling units.

**(156)** "Multipurpose piping system" means a type of water distribution system conveying potable water to plumbing fixtures and appliances and automatic fire sprinklers with the intention of serving both domestic water needs and fire protection needs within an one- or 2- family dwelling or manufactured dwelling.

**(157)** "Municipality" means any city, village, town or county in this state.

**(158)** "Munsell soil color" means a color classification that specifies the relative degrees of the color variables in terms of hue, value and chroma.

**(159)** "Navigable waters" has the meaning specified under s. NR 115.03 (5).

Note: Section NR 115.03 (5) reads:

"Navigable waters" means Lake Superior, Lake Michigan, all natural inland lakes within Wisconsin and all streams, ponds, sloughs, flowages and other waters within the territorial limits of this state, including the Wisconsin portion of boundary waters, which are navigable under the laws of this state. Under s. 281.31 (2) (d), Stats., not withstanding any other provision of law or administrative rule promulgated thereunder, shoreland ordinances required under s. 59.971, Stats., and this chapter do not apply to lands adjacent to farm drainage ditches if:

- (a) Such lands are not adjacent to a natural navigable stream or river;
- (b) Those parts of such drainage ditches adjacent to such lands were nonnavigable streams before ditching or had no previous stream history; and
- (c) Such lands are maintained in nonstructural agricultural use.

**(160)** "Negative pressure" means a pressure less than atmospheric.

**(160m)** "Noncontinuous pressure" means a pressure greater than atmospheric and exerted for a period of no more than 12 continuous hours.

**(161)** "Nonpotable water" means water not safe for drinking, personal or culinary use.

**(162)** "Nonpublic" means, in the classification of plumbing fixtures, those fixtures in residences, apartments, living units of hotels and motels, and other places where the fixtures are intended for the use by a family or an individual to the exclusion of all others.

**(163)** "Nontoxic" means a probable human oral lethal dose of greater than 15 grams of solution per kilogram of body weight.

**(163e)** "Nursing home" has the meaning specified under s. 50.01 (3), Stats.

Note: Section 50.01 (3), Stats., reads:

"Nursing home" means a place where 5 or more persons who are not related to the operator or administrator reside, receive care or treatment and, because of their mental or physical condition require access to 24-hour nursing services, including limited nursing care, intermediate level nursing care and skilled nursing services. "Nursing home" does not include any of the following:

- (c) A convent or facility owned or operated exclusively by and for members of a religious order that provides reception and care or treatment of an individual.
- (d) A hospice, as defined in s. 50.90 (1), Stats., that directly provides inpatient care.
- (e) A residential care apartment complex.

**(164)** "Occupancy" means the purpose for which a building, structure, equipment, materials, or premises, or part thereof, is used or intended to be used.

**(165)** "Oil interceptor" means a device designed to intercept and retain oil, lubricating grease or other similar materials.

**(166)** "Offset" means a combination of fittings or bends which brings one section of the pipe out of line but into a line parallel with the other section.

**(167)** "One or 2-family dwelling" means a building containing not more than 2 dwelling units.

**(168)** "Open air" means outside the building.

**(168m)** "Open bodies of water" means those portions of Lake Michigan and Lake Superior within the boundaries of Wisconsin, all lakes, bays, rivers, streams, springs, ponds, wells, impounding reservoirs, marshes, watercourses, drainage systems and other surface water, natural or artificial, public or private within the state or under its jurisdiction.

**(169)** "Ordinary high-water mark" has the meaning specified under s. NR 115.03 (6).

Note: Section NR 115.03 (6), reads:

"Ordinary high-water mark" means the point on the bank or shore up to which the presence and action of surface water is so continuous as to leave a distinctive mark such as by erosion, destruction or prevention of terrestrial vegetation, predominance of aquatic vegetation, or other easily recognized characteristic. Where the bank or shore at any particular place is of such character that it is difficult or impossible to ascertain where the point of ordinary high-water mark is, recourse may be had to the opposite bank of a stream or to other places on the shore of a lake or flowage to determine whether a given stage of water is above or below the ordinary high-water mark.

**(170)** "Participating governmental unit" means a governmental unit which applies to the department for financial assistance under s. Comm 87.60, and which meets the conditions specified under s. 145.245 (9), Stats.

**(170e)** "Patient area plumbing fixture" means a plumbing fixture that is accessible to patients in a health care facility and is intended to be used for culinary, hygienic or domestic purposes.

**(171)** "Peak flow" means the largest anticipated recurrent wastewater discharge to a private onsite wastewater treatment system.

**(172)** "Pipe applied atmospheric type vacuum breaker" means a type of cross connection control device where the flow of water into the device causes a float to close an air inlet port and when the flow of water stops the float falls and forms a check valve against back siphonage and at the same time opens the air inlet port to allow air to enter and satisfy the vacuum.

**(173)** "Pit privy" means an enclosed nonportable toilet into which nonwater-carried human wastes are deposited to a subsurface storage chamber that is not watertight.

**(174)** "Pitch" means the gradient or slope of a line of pipe in reference to a horizontal plane.

**(175)** "Place of employment" has the meaning specified under s. 101.01 (11), Stats.

Note: Section 101.01 (11), Stats., reads:

"Place of employment" includes every place, whether indoors or out or under ground and the premises appurtenant thereto where either temporarily or permanently any industry, trade or business is carried on, or where any process or operation, directly or indirectly related to any industry, trade or business, is carried on, and where any person is, directly or indirectly, employed by another for direct or indirect gain or profit, but does not include any place where persons are employed in private domestic service which does not involve the use of mechanical power or in farming. "Farming" includes those activities specified in s. 102.04 (3), and also includes the transportation of farm products, supplies or equipment directly to the farm by the operator of said farm or employees for the use thereon, if such activities are directly or indirectly for the purpose of producing commodities for market, or as an accessory to such production. When used with relation to building codes, "place of employment" does not include an adult family home, as defined in s. 50.01 (1), or, except for the purposes of s. 101.11, a previously constructed building used as a community-based residential facility, as defined in s. 50.01 (1g), which serves 20 or fewer unrelated residents.

**(176)** "Plumbing" has the meaning specified under s. 145.01 (10), Stats.

Note: Section 145.01 (10), Stats., reads:

"Plumbing" means and includes:

(a) All piping, fixtures, appliances, equipment, devices and appurtenances in connection with the water supply, water distribution and drainage systems, including hot water storage tanks, water softeners and water heaters connected with such water and drainage systems and also includes the installation thereof.

(b) The construction, connection or installation of any drain or waste piping system from the outside or proposed outside foundation walls of any building to the mains or other sewage system terminal within bounds of, or beneath an area subject to easement for highway purposes, including private sewage systems, and the alteration of any such systems, drains or waste piping.

(c) The water service piping from the outside or proposed outside foundation walls of any building to the main or other water utility service terminal within bounds of, or beneath an area subject to easement for highway purposes and its connections.

(d) The water pressure system other than municipal systems as provided in ch. 281.

(e) A plumbing and drainage system so designed and vent piping so installed as to keep the air within the system in free circulation and movement; to prevent with a margin of safety unequal air pressures of such force as might blow, siphon or affect trap seals, or retard the discharge from plumbing fixtures, or permit sewer air to escape into the building; to prohibit cross-connection, contamination or pollution of the potable water supply and distribution systems, and to provide an adequate supply of water to properly serve, cleanse and operate all fixtures, equipment, appurtenances and appliances served by the plumbing system.

**(177)** "Plumbing appliance" means any one of a special class of plumbing devices which is intended to perform a special function. The operation or control of the appliance may be dependent upon one or more energized components, such as motors, con

trols, heating elements, or pressure or temperature sensing elements. The devices may be manually adjusted or controlled by the user or operator, or may operate automatically through one or more of the following actions: a time cycle, a temperature range, a pressure range, or a measured volume or weight.

**(178)** "Plumbing fixture" means a receptacle or device which meets at least one of the following:

(a) Is either permanently or temporarily connected to the water supply system of the premises, and demands a supply of water from the system;

(b) Discharges wastewater or waste materials either directly or indirectly to the drain system of the premises.

(c) Requires both a water supply connection and a discharge to the drain system of the premises.

**(179)** "Plumbing system" includes the water supply system, the drain system, the vent system, plumbing fixtures, plumbing appliances and plumbing appurtenances that serve a building, structure or premises.

**(180)** "Point of standards application" has the meaning specified under s. 160.01 (5), Stats.

Note: Section 160.01 (5) Stats., reads:

"Point of standards application" means the specific location, depth or distance from a facility, activity or practice at which the concentration of a substance in groundwater is measured for purposes of determining whether a preventive action limit or an enforcement standard has been attained or exceeded.

**(181)** "Potable water" means water that is both:

(a) Safe for drinking, personal or culinary use.

(b) Free from impurities present in amounts sufficient to cause disease or harmful physiological effects.

**(182)** "POWTS" means a private onsite wastewater treatment system.

**(183)** "POWTS component" means any subsystem, subassembly or other system designed for use in or as part of a private onsite wastewater treatment system which may include treatment, dispersal or holding and related piping.

**(184)** "POWTS dispersal component" means a device or method that is intended to promote the assimilation of treated wastewater by the environment.

**(185)** "POWTS holding component" means any receptacle intended to collect wastewater for a period of time, including holding and dosing tanks.

**(186)** "POWTS treatment component" means a device or method that is intended to reduce the contaminant load of waste water.

**(187)** "Prefabricated plumbing" means concealed drain piping, vent piping or water supply or a combination of these types of piping, contained in a modular building component, which will not be visible for inspection when delivered to the final site of installation.

**(187e)** "Prefabricated sump and pump system" means a simplex or duplex pump and sump designed as a combined unit.

**(188)** "Pressure relief valve" means a pressure actuated valve held closed by a spring or other means and designed to automatically relieve pressure at a designated pressure.

**(189)** "Pressure vacuum breaker assembly" means a type of cross connection control device which consists of an independently operating internally loaded check valve and an independently operating loaded air inlet located on the discharge side of the check valve, a tightly closing shut-off valve located at each end of the assembly, and test cocks. The term "PVB" has the same meaning as pressure vacuum breaker assembly.

**(190)** "Pressurized flushing device" means a device that uses the water supply to create a pressurized discharge to flush a fixture exclusive of gravity type flushing systems.

**(191)** "Preventive action limit" or "PAL" has the meaning as specified under s. 160.01 (6), Stats.

Note: Section 160.01 (6), Stats., reads:

"Prevention action limits" means a numerical value expressing the concentration of a substance in groundwater which is adopted under s. 160.15, Stats., and specified under s. NR 140.10 or 140.12.

**(192)** "Principal residence" means a residence that is occupied at least 51% of the year by the owner. Principal residence includes a residence owned by a trust or estate of an individual, if the residence is occupied at least 51% of the year by a person who has an ownership interest in the residence as a beneficiary of the trust or estate.

**(193)** "Private interceptor main sewer" means a sewer serving 2 or more buildings and not part of the municipal sewer system.

**(194)** "Private onsite wastewater treatment system" has the meaning given for 'private sewage system' under s. 145.01 (12), Stats.

Note: Section 145.01 (12), Stats., reads:

"Private sewage system" means a sewage treatment and disposal system serving a single structure with a septic tank and soil absorption field located on the same parcel as the structure. This term also means an alternative sewage system approved by the department including a substitute for the septic tank or soil absorption field, a holding tank, a system serving more than one structure or a system located on a different parcel than the structure. A private sewage system may be owned by the property owner or by a special purpose district.

**(195)** "Private water main" means a water main serving 2 or more buildings and not part of the municipal water system.

**(196)** "Public" means, in the classification of plumbing fixtures, those fixtures which are available for use by the public or employees.

**(197)** "Public building" has the meaning specified under s. 101.01 (12), Stats.

Note: Section 101.01 (12), Stats., reads:

"Public building" means any structure, including exterior parts of such building, such as a porch, exterior platform or steps providing means of ingress or egress, used in whole or in part as a place of resort, assemblage, lodging, trade, traffic, occupancy, or use by the public or by 3 or more tenants. When used in relation to building codes, "public building" does not include a previously constructed building used as a community-based residential facility as defined in s. 50.01 (1g) which serves 20 or fewer unrelated residents or an adult family home, as defined in s. 50.01 (1).

**(198)** "Public sewer" means a sewer owned and controlled by a public authority.

**(199)** "Public water main" means a water supply pipe for public use owned and controlled by a public authority.

**(199e)** "PVB" has the same meaning as specified in sub. (189).

**(200)** "Quick closing valve" means a valve or faucet that closes automatically when released manually or controlled by mechanical means for fast action closing.

**(201)** "Receptor" means a fixture or device that receives the discharge from indirect or local waste piping.

**(202)** "Redoximorphic feature" means a feature formed in the soil matrix by the processes of reduction, translocation and oxidation of iron and manganese compounds in seasonally saturated soil.

**(203)** "Reduced pressure detector backflow preventer" means a type of reduced pressure principle type backflow preventer which includes a parallel flow meter to indicate leakage or unauthorized use of water downstream of the assembly. The term "RP detector" has the same meaning as reduced pressure detector backflow preventer.

**(204)** "Reduced pressure principle backflow preventer" means a type of cross connection control device which contains 2 independently acting check valves, separated by an intermediate chamber or zone in which there is a hydraulically operated means for venting to atmosphere, and includes 2 shut-off valves and 4 test cocks. The term "RP" has the same meaning as reduced pressure principle backflow preventer.

**(205)** "Relief vent" means a vent which permits additional circulation of air in or between drain and vent systems.

**(206)** "Riser" means a water supply pipe that extends vertically one full story or more.

(207) "Roof drain" means a drain installed to receive water collecting on the surface of a roof and to discharge it into a conductor.

(208) "Roughing in" means the installation of all parts of the plumbing system which can be completed prior to the installation of fixtures including drain, water supply and vent piping and the necessary fixture supports.

(209) "Rowhouse" means a building which is not more than 3 stories in height and which contains only 3 or more attached, vertically separated, side-by-side or back-to-back dwelling units, with each dwelling unit served by an individual exterior exit within 6 feet of the exit discharge grade.

(209e) "RP" has the same meaning as specified in sub. (204).

(209m) "RP detector" has the same meaning as specified in sub. (203).

(210) "Safing" means a membrane or material installed beneath a fixture to prevent leakage from escaping to the floor, ceiling or walls.

(211) "Sand interceptor" means a receptacle designed to intercept and retain sand, grit, earth and other similar solids.

(212) "Sanitary sewer" means a pipe that carries wastewater consisting in part of domestic wastewater.

(212e) "Scrub sink" means a plumbing fixture used for hand and arm washing prior to surgery or other medical procedures.

Note: A scrub sink may also be referred to as a surgeon washup sink.

(213) "Scum" means the accumulated floating solids generated during the biological, physical or chemical treatment, coagulation or sedimentation of wastewater.

(214) "Secretary" means the secretary of the department of commerce or designee.

(214m) "Service sink" means a fixture designed to be used for building or facility maintenance.

Note: A service sink may also be referred to as a mop sink, mop basin or janitor's sink.

(215) "Servicing" has the meaning as specified under s. NR 113.03 (57).

Note: Under s. NR 113.03 (57) "servicing" means removing the scum, liquid, sludge or other wastes from a private sewage system such as septic or holding tanks, dosing chambers, grease interceptors, seepage beds, seepage pits, seepage trenches, privies or portable restrooms and properly disposing or recycling of the contents as provided in this chapter.

(216) "Sewage" means wastewater containing fecal coliform bacteria exceeding 200 CFU, colony forming units, per 100 ml.

(217) "Sewage grinder pump" means a type of sewage pump which macerates wastewater consisting in part of sewage.

(218) "Sewage pump" means an automatic pump for the removal of wastewater from a sanitary sump.

(219) "Slip-joint" means a connection in which one pipe slips into another, the joint of which is made tight with a compression type fitting.

(220) "Sludge" means the accumulated solids generated during the biological, physical or chemical treatment, coagulation or sedimentation of water or wastewater.

(221) "Small commercial establishment" means a commercial establishment or business place with a maximum daily wastewater flow rate of less than 5,000 gallons per day as determined from the design criteria of the state plumbing code. Small commercial establishment includes a farm, including a residence on a farm, if the residence is occupied by a person who is an operator of the farm and if the maximum daily wastewater flow rate of the farm and the residence on the farm is less than 5,000 gallons-per-day as determined from the design criteria of the state plumbing code.

(222) "Soil" means the naturally occurring pedogenically developed and undeveloped regolith overlying bedrock.

(223) "Soil consistence" means the resistance of soil material to deformation or rupture as related to the degree of adhesion and cohesion of a soil mass.

(224) "Soil horizon" means a layer of soil material approximately parallel to the land surface and differing from adjacent genetically related layers in physical, chemical, or biologic characteristics.

(225) "Soil morphology" means the physical or structural characteristics of a soil profile particularly as related to the arrangement of soil horizons based on color, texture, structure, consistence, and porosity.

(226) "Soil profile" means a vertical section of soil containing one or more soil horizons.

(227) "Soil profile evaluation" means a determination of soil properties or characteristics as they relate to wastewater or non-water-carried human waste treatment or dispersal.

(228) "Soil structure" means the combination or arrangement of individual soil particles into definable aggregates or peds, which are characterized and classified on the basis of size, shape, and degree of distinctness.

(229) "Soil texture" means the relative proportions of sand, silt and clay (soil separates) in a soil.

(230) "Spigot" means the end of a pipe which fits into a bell or hub.

(231) "Spill level" means the horizontal plane to which water will rise to overflow through channels or connections which are not directly connected to any drainage system, when water is flowing into a fixture, vessel or receptacle at the maximum rate of flow.

(232) "Spring line, pipe" means the line or place from which the arch of a pipe or conduit rises.

Note: See ch. Comm 82 Appendix for an illustration depicting the spring line of a pipe.

(233) "Stack" means a drain or vent pipe that extends vertically one full story or more.

(234) "Stack vent" means a vent extending from the top of a drain stack.

(235) "Standpipe" means a drain pipe serving as a receptor for the discharge wastes from indirect or local waste piping.

(236) "State" means the state of Wisconsin, its agencies and institutions.

(237) "State plumbing code" means chs. Comm 81 to 87.

(238) "Sterilizer, boiling type" means a device of nonpressure type, used for boiling instruments, utensils, or other equipment for disinfecting.

(239) "Sterilizer, instrument" means a device for the sterilization of various instruments.

(240) "Sterilizer, pressure" means a pressure vessel fixture designed to use steam under pressure for sterilizing.

Note: A pressure sterilizer is also referred to as an autoclave.

(241) "Sterilizer, pressure instrument washer" means a pressure vessel designed to both wash and sterilize instruments during the operating cycle of the device.

(242) "Sterilizer, utensil" means a device for the sterilization of utensils.

(243) "Sterilizer vent" means a separate pipe or stack, indirectly connected to the drain system at the lower terminal, which receives the vapors from nonpressure sterilizers, or the exhaust vapors from pressure sterilizers, and conducts the vapors directly to the outer air.

(244) "Sterilizer, water" means a device for sterilizing water and storing sterile water.

(245) "Storm sewer" means a pipe, other than a pipe located inside a building, that carries any of the following: storm water, groundwater or clear water.

(246) "Storm water" means wastewater from a precipitation event.

(247) "Subsoil drain" means that part of a drain system that conveys groundwater to a point of discharge or dispersal.



**(248)** "Sump" means a tank or pit that receives wastewater that must be emptied by mechanical means.

**(249)** "Sump pump" means an automatic device located in a sump, pit or low point that is designed to elevate storm water, groundwater or clear water.

**(250)** "Sump vent" means a vent pipe from a nonpressurized sump.

**(251)** "Supports" means hangers, anchors and other devices for supporting and securing pipes or fixtures to structural members of a building.

**(252)** "Surface water" means those portions of Lake Michigan and Lake Superior within the boundaries of Wisconsin, all lakes, bays, rivers, streams, springs, ponds, impounding reservoirs, marshes, water courses, drainage systems, and other surface water, natural or artificial, public or private within the state or under its jurisdiction, except those waters which are entirely confined and completely retained upon the property of a facility.

**(252e)** "SVB" has the same meaning as specified in sub. (20).

**(253)** "Swimming pool" means a structure, basin, chamber or tank containing an artificial body of water for swimming, diving or recreational bathing.

**(254)** "Temperature and pressure relief valve" means a combination relief valve designed to function as both a temperature relief and pressure relief valve.

**(255)** "Temperature relief valve" means a temperature actuated valve designed to automatically discharge at a designated temperature.

**(256)** "Tempered water" means water ranging in temperature from 85°F. to less than 110°F.

**(257)** "Total suspended solids" or "TSS" means solids in wastewater that can be removed readily by standard filtering procedures in a laboratory and reported as milligrams per liter (mg/L).

**(258)** "Toxic" means a probable human oral lethal dose of 15 or less grams of solution per kilogram of body weight.

**(259)** "Trap" means a fitting, device or arrangement of piping so designed and constructed as to provide, when properly vented, a liquid seal which prevents emission of sewer gases without materially affecting the flow of wastewater through it.

**(260)** "Trap seal" means the vertical distance between the top of the trap weir and the top of the dip separating the inlet and outlet of the trap.

**(261)** "Trap seal primer, water supply fed" means a type of valve designed to supply water to the trap in order to provide and maintain the water seal of the trap.

**(262)** "Trap weir" means that part of a trap that forms a dam over which wastes must flow to enter the drain piping.

**(263)** "Turf sprinkler system" means a system of piping, appurtenances and devices installed underground to distribute water for lawn or other similar irrigation purposes.

**(264)** "Unsaturated soil" means soil in which the pore spaces contain water at less than atmospheric pressure, as well as air and other gases.

**(265)** "Vacuum" means any pressure less than that exerted by the atmosphere.

**(265e)** "Vacuum breaker tee" means an assembly of fittings designed to eliminate the possibility of back siphonage in a system by allowing air to enter through a tee fitting.

**(266)** "Vacuum relief valve" means a device that admits air into the water distribution system to prevent excessive vacuum in a water storage tank or heater.

**(267)** "Vent" means a part of the plumbing system used to equalize pressures and ventilate the system.

**(268)** "Vent header" means a branch vent which connects 2 or more stack vents or vent stacks or both and extends to the outside air.

**(269)** "Vent stack" means a vertical vent pipe which extends one or more stories.

**(270)** "Vent system" means a pipe or pipes installed to provide a flow of air to or from a drain system, or to provide a circulation of air within the system to protect trap seals from siphonage and back pressure.

**(271)** "Vertical pipe" means any pipe or fitting which makes an angle of 45° or less with the vertical.

**(272)** "Wall hydrant, freeze resistant automatic draining type vacuum breaker" means a type of device which is designed and constructed with anti-siphon and back pressure preventive capabilities and with means for automatic post shut-off draining to prevent freezing.

**(273)** "Wall mounted water closet" means a water closet attached to a wall in such a way that it does not touch the floor.

**(273e)** "Washer sanitizer" means a plumbing appliance used for washing and disinfecting equipment.

**(274)** "Waste" means the discharge from any fixture, appliance, area or appurtenance.

**(275)** "Waste sink" means a receptor for the discharge from indirect or local waste piping installed with its flood level rim above the surrounding floor.

**(276)** "Wastewater" means clear water, storm water, domestic wastewater, industrial wastewater, sewage or any combination of these.

**(277)** "Wastewater, treated" means the effluent conveyed through one or more POWTS treatment components to a POWTS dispersal component.

**(277e)** "Wastewater treatment device" means a device or method that is intended to beneficially alter the characteristics of wastewater.

**(278)** "Water closet" means a water-flushed plumbing fixture designed to receive human excrement directly from the user of the fixture.

**(279)** "Water conditioner" means an appliance, appurtenance or device used for the purpose of ion exchange, demineralizing water or other methods of water treatment.

**(280)** "Water distribution system" means that portion of a water supply system from the building control valve to the connection of a fixture supply connector, plumbing fixture, plumbing appliance, water-using equipment or other piping systems to be served.

**(281)** "Water heater" means any heating device with piping connections to the water supply system that is intended to supply hot water for domestic or commercial purposes other than space heating.

**(282)** "Water service" means that portion of a water supply system from the water main or private water supply to the building control valve.

**(283)** "Waters of the state" has the meaning specified under s. 281.01 (18), Stats.

Note: Section 281.01 (18), Stats., reads:  
"Waters of the state" means those portions of Lake Michigan and Lake Superior within the boundaries of Wisconsin, all lakes, bays, rivers, streams, springs, ponds, wells, impounding reservoirs, marshes, watercourses, drainage systems and other surface water or groundwater, natural or artificial, public or private within the state or under its jurisdiction.

**(284)** "Water supply system" means the piping of a private water main, water service and water distribution system, fixture supply connectors, fittings, valves, and appurtenances through which water is conveyed to points of usage such as plumbing fixtures, plumbing appliances, water using equipment or other piping systems to be served.

**(285)** "Water treatment device" means a device which:

(a) Renders inactive or removes microbiological, particulate, inorganic, organic or radioactive contaminants from water which passes through the device or the water supply system downstream of the device; or

(b) Injects into the water supply system gaseous, liquid or solid additives other than water, to render inactive microbiological, particulate, inorganic, organic or radioactive contaminants.

**(286)** "Wetland" has the meaning as specified under s. NR 322.03 (11).

**Note:** Section NR 322.03(11) reads:  
 "Wetland" means an area where water is at, near or above the land surface long enough to be capable of supporting aquatic or hydrophytic vegetation and which has soil indicative of wet conditions.

**(287)** "Wetland, constructed" means a man-made design complex of saturated substrates, emergent and submergent vegetation, and water that simulate natural wetlands for human use and benefits.

**(288)** "Wet vent" means that portion of a vent pipe which receives the discharge of wastes from other than water closets, urinals or other fixtures which discharge like sewage or fecal matter.

**(288e)** "Whirlpool" has the meaning as specified under s. Comm 90.03 (11) (k).

**Note:** Section Comm 90.03 (11) (k) reads:  
 "Whirlpool" means a relatively small pool which uses high temperature water and which may include a water agitation system. A "whirlpool" is sometimes called a spa.  
**Note:** A fill and dump bathtub is not a whirlpool.

**(288m)** "Whirlpool bath tub" means a plumbing appliance consisting of a bathtub fixture that is equipped and fitted with a circulation piping system designed to accept, circulate and discharge bathtub water upon each use.

**(289)** "Yoke vent" means a vent connected to a drain stack for the purpose of preventing pressure changes in the drain stack.

**History:** Cr. Register, April, 2000, No. 532, eff. 7-1-00; cr. (7e), (17e), (60e), (67e), (67m), (82m), (90e), (163e), (170e), (199e), (209e), (209m), (252e), (288e) and (288m), am. (18), (20), (79), (80), (189), (203) and (204), r. and recr. (116), Register, December, 2000, No. 540, eff. 1-1-01; CR 01-139: am. (209) Register June 2002 No. 558, eff. 7-1-02; corrections in (152) and (154) made under s. 13.93 (2m) (b) 7., Stats., Register June 2002 No. 558; CR 02-002: am. (7e), (42), (44), (46), (56), (80), (84), (90e), (120), (134), (147), (178), (181), (193), (195), (210), (245), (246), (247), and (276), cr. (7m), (35m), (51m), (56e), (61m), (62m), (65m), (72e), (90m), (108m), (160m), (187e), (212e), (214m), (265e), (273e), and (277e), r. and recr. (249) Register April 2003 No. 568, eff. 5-1-03; CR 02-129: cr (2m) and (168m) Register January 2004 No. 577, eff. 2-1-04.

**Comm 81.20 Incorporation of standards by reference. (1) CONSENT.** Pursuant to s. 227.21 (2), Stats., the attorney

general and the revisor of statutes have consented to the incorporation by reference of the standards listed in sub. (3).

**Note:** Copies of the adopted standards are on file in the offices of the department, the secretary of state and the revisor of statutes. Copies of the standards may be purchased through the respective organizations listed in Tables 81.20-1 to 81.20-13.

**(2) ALTERNATE STANDARDS.** (a) Alternate standards that are equivalent to or more stringent than the standards referenced in this code may [be] used in lieu of the referenced standards when approved by the department or if written approval is issued by the department in accordance with par. (b).

1. Upon receipt of a fee and a written request, the department may issue an approval for the use of the alternate standard.

2. The department shall review and make a determination on an application for approval within 40 business days of receipt of all forms, fees and documents required to complete the review.

**Note:** Review fees for standards under this paragraph are listed in ch. Comm 2.  
 (b) Determination of approval shall be based on an analysis of the alternate standard and the standard referenced in this code, prepared by a qualified independent third party or the organization that published the standard contained in this code.

(c) The department may include specific conditions in issuing an approval, including an expiration date for the approval. Violations of the conditions under which an approval is issued shall constitute a violation of this code.

(d) If the department determines that the alternate standard is not equivalent to or more stringent than the referenced standard, the request for approval shall be denied in writing.

(e) The department may revoke an approval for any false statements or misrepresentations of facts on which the approval was based.

(f) The department may reexamine an approved alternate standard and issue a revised approval at any time.

**(3) ADOPTION OF STANDARDS.** The standards referenced in Tables 81.20-1 to 81.20-13 are hereby incorporated by reference into this chapter.

**Note:** The tables in this section provide a comprehensive listing of all of the standards adopted by reference in this code. For requirements or limitations in how these standards are to be applied, refer to the code section that requires compliance with the standard.

**Table 81.20-1**

<b>AHAM</b>		<b>Association of Home Appliance Manufacturers 20 North Wacker Drive Chicago, Illinois 60606</b>
Standard Reference Number	Title	
DW-1-92	Household Electric Dishwashers	

**Table 81.20-2**

<b>ANSI</b>		<b>American National Standards Institute, Inc. 1430 Broadway New York, New York 10018</b>
Standard Reference Number	Title	
1. Z21.22a-90	Relief Valves and Automatic Gas Shutoff Devices for Hot Water Supply Systems	
2. Z21.61-83	Gas-Fried Toilets	
3. Z124.1-95	Plastic Bathtub Units	
4. Z124.2-95	Plastic Shower Receptors and Shower Stalls	
5. Z124.3-95	Plastic Lavatories	
6. Z124.4-96	Plastic Water Closet Bowls and Tanks	
7. Z124.6-97	Plastic Sinks	
8. Z124.9-94	Fixtures, Plastic Urinal, American National Standard for	

Table 81.20-3

<b>ARI</b>	
<b>Air-Conditioning and Refrigeration Institute</b>	
<b>1815 North Fort Myer Drive</b>	
<b>Arlington, Virginia 22209</b>	
<b>Standard Reference Number</b>	<b>Title</b>
ARI-1010-94	Self-Contained Mechanically-Refrigerated Drinking-Water Coolers

Table 81.20-3e

<b>ASME</b>	
<b>American Society of Mechanical Engineers</b>	
<b>345 East 47th Street</b>	
<b>New York, New York 10017</b>	
<b>Phone: (800) THE-ASME</b>	
<b>Web page: <a href="http://www.infocentral@asme.org">www.infocentral@asme.org</a></b>	
<b>Standard Reference Number</b>	<b>Title</b>
1. A112.1.2-91 (R1998)	Air Gaps in Plumbing Systems
1e. A112.1.3-00	Air-gap Fittings for Use with Plumbing Fixtures, Appliances, and Appurtenances
2. A112.6.1M-97	Floor-Affixed Supports for Off-the-Floor Plumbing Fixtures for Public Use
3. A112.14.1-75 (R1998)	Backwater Valves
4. A112.18.1M-96	Plumbing Fixture Fittings
5. A112.19.1M-94	Enameled Cast Iron Plumbing Fixtures
6. A112.19.2M-95	Vitreous China Plumbing Fixtures
7. A112.19.3M-87 (R1996)	Stainless Steel Plumbing Fixtures (Designed for Residential Use)
8. A112.19.4-94	Porcelain Enameled Formed Steel Plumbing Fixtures
9. A112.19.5-79 (R1998)	Trim for Water-Closet Bowls, Tanks, and Urinals (Dimensional Standards)
10. A112.19.6-95	Hydraulic Performance Requirements for Water Closets and Urinals
11. A112.21.1M-91	Floor Drains
12. A112.21.2M-83	Roof Drains
13. B1.20.1-83 (R1992)	Pipe Threads, General Purpose (Inch)
14. B16.1-89	Cast Iron Pipe Flanges and Flanged Fittings
15. B16.3-92	Malleable Iron Threaded Fittings
16. B16.4-92	Gray Iron Threaded Fittings
17. B16.5a-98	Pipe Flanges and Flanged Fittings NPS 1/2 Through NPS 24 (and addenda)
18. B16.9-93	Factory-Made Wrought Steel Butt welding Fittings
19. B16.11-96	Forged Fittings, Socket-Welding and Threaded
20. B16.12-91	Cast Iron Threaded Drainage Fittings
21. B16.15-85 (R1994)	Cast Bronze Threaded Fittings, Classes 125 and 250
22. B16.18-84 (R1994)	Cast Copper Alloy Solder Joint Pressure Fittings
23. B16.22-95	Wrought Copper and Copper Alloy Solder-Joint Pressure Fittings
24. B16.23-92	Cast Copper Alloy Solder Joint Drainage Fittings-DWV
25. B16.24-91	Cast Copper Alloy Pipe Flanges and Flanged Fittings, Class 150, 300, 400, 600, 900, 1500 and 2500
26. B16.26-88	Cast Copper Alloy Fittings for Flared Copper Tubes
27. B16.28-94	Wrought Steel Butt welding Short Radius Elbows and Returns
28. B16.29-94	Wrought Copper and Wrought Copper Alloy Solder Joint Drainage Fittings - DWV
29. B16.42-87 (R1997)	Ductile Iron Pipe Flanges and Flanged Fittings
30. B16.45-87 (R1997)	Cast Iron Fittings for Solvent® Drainage Systems
31. B36.19M-85 (R1994)	Stainless Steel Pipe

Table 81.20-4

		<b>American Society of Sanitary Engineering P.O. Box 9712 Bay Village, Ohio 44140</b>
<b>Standard Reference Number</b>	<b>Title</b>	
1.	1001-90	Pipe Applied Atmospheric Type Vacuum Breakers
2.	1002-86	Water Closet Flush Tank Ball Cocks
3.	1003-95	Water Pressure Reducing Valves
4.	1004-90	Commercial Dishwashing Machines
5.	1005-86	Water Heater Drain Valves
6.	1006-89	Residential Use (Household) Dishwashers
7.	1007-92	Home Laundry Equipment
8.	1008-89	Household Food Waste Disposer Units
9.	1009-90	Commercial Food Waste Grinder Units
10.	1010-96	Water Hammer Arresters
11.	1011-95	Hose Connection Vacuum Breakers
12.	1012-93	Backflow Preventers with Intermediate Atmospheric Vent
13.	1013-99	Reduced Pressure Detector Fire Protection Backflow Prevention Assemblies
14.	1014-90	Hand-Held Showers
15.	1015-99	Double Check Fire Protection Backflow Prevention
15e.	1016-96	Individual Thermostatic, Pressure Balancing, and Combination Pressure Balancing and Thermostatic Control Valves for Individual Fixture Fittings
16.	1018-88	Trap Seal Primer Valves, Water Supply Fed
17.	1019-97	Vacuum Breaker Wall Hydrants, Freeze Resistant Automatic Draining Type
18.	1020-89	Pressure Vacuum Breaker Assembly
18e.	1022-96	Backflow Preventer for Carbonated Beverage Machines
19.	1023-79	Hot Water Dispensers, Household Storage Type, Electrical
20.	1025-78	Diverter for Plumbing Faucets with Hose Spray, Anti-Siphon Type, Residential Applications
21.	1035-95	Laboratory Faucet Backflow Preventers
22.	1037-90	Pressurized Flushing Devices (Flushometers) for Plumbing Fixtures
22e.	1043-92	Cast Iron Solvent <sup>®</sup> Sanitary Drain Systems
23.	1047-99	Reduced Pressure Detector Fire Protection Backflow Prevention Assemblies
24.	1048-99	Double Check Fire Protection Backflow Prevention Assemblies
25.	1052-94	Hose Connection Backflow Preventers
25e.	1055-97	Chemical Dispensing Systems
26.	1056-95	Back Siphonage Vacuum Breakers
26e.	1066-97	Individual Pressure Balancing In-Line Valves for Individual Fixture Fittings

Table 81.20-5

		<b>American Society for Testing and Materials 100 Barr Harbor Drive West Conshohocken, Pennsylvania 19428-2959 Phone: (610) 832-9585 Web page: www.astm.org</b>
<b>Standard Reference Number</b>	<b>Title</b>	
1.	A53-97	Pipe, Steel, Black and Hot-Dipped, Zinc-Coated Welded and Seamless, Specification for
2.	A74-96	Cast Iron Soil Pipe and Fittings, Specification for
3.	A123/A123M-97a	Zinc (Hot-Galvanized) Coatings on Products, Specification for
4.	A270-95a	Seamless and Welded Austenitic Stainless Steel Sanitary Tubing, Specification for
5.	A377-95	Ductile-Iron Pressure Pipe, Standard Index of Specifications for
6.	A403/A403M-97a	Wrought Austenitic Stainless Steel Piping Fittings, Specification for
7.	A450/A450M-96	Carbon, Ferritic Alloy, and Austenitic Alloy Steel Tubes

Table 81.20-5 (Continued)

ASTM		American Society for Testing and Materials 100 Barr Harbor Drive West Conshohocken, Pennsylvania 19428-2959 Phone: (610) 832-9585 Web page: www.astm.org
Standard Reference Number	Title	
7e.	A888-98	Hubless Cast Iron Soil Pipe and Fittings for Sanitary and Storm Drain, Waste, and Vent Pipe Applications, Specifications for
8.	B32-96	Solder Metal
9.	B42-93	Pipe, Seamless Copper, Standard Sizes
10.	B43-96	Seamless Red Brass Pipe, Standard Sizes, Specification for
11.	B88/B88M-96	Water, Seamless, Copper Tube
12.	B152/B152M-97a	Copper Sheet, Strip, Plate, and Rolled Bar, Specification for
13.	B251/B251M-97	Tube, Wrought Seamless Copper and Copper
14.	B302-97	Threadless Copper Pipe, Specification for
15.	B306-96	Standard Specifications for Copper Drainage Tube (DWV)
15s.	B828-98	Making Capillary Joints by Soldering of Copper and Copper Alloy Tube and Fittings, Practice for
17.	C14/C14M-95	Concrete Sewer, Storm Drain, and Culvert Pipe, Specification for
18.	C33-97	Concrete Aggregates
19.	C76-98	Culvert, Storm Drain, and Sewer Pipe, Reinforced Concrete
20.	C76M-97	Reinforced Concrete Culvert, Storm Drain, and Culvert Pipe (metric), Specifications for
21.	C425-97	Clay Pipe and Fittings for Vitrified Compression Joints
22.	C443/C443M-94	Specification for Joints for Circular Concrete Sewer and Culvert Pipe, Using Rubber Gaskets
22e.	C507/C507M-95a	Reinforced Concrete Elliptical Culvert, Storm Drain and Sewer, Specifications for
23.	C564-97	Rubber Gaskets for Cast Iron Soil Pipe and Fittings, Specification for
24.	C700-97	Vitrified Clay Pipe, Extra Strength, Standard Strength, and Perforated, Specification for
24e.	C877/C877M-94	External Sealing Bands for Noncircular Concrete Sewer, Storm Drain, and Culvert Pipe, Specifications for
24h.	C923-98	Resilient Connectors Between Reinforced Concrete Manhole Structures, Pipes, and Laterals, Specification for
24m.	C990/C990M-96	Joints for Concrete Pipe, Manholes, Precast Box Sections Using Preformed Flexible Joint Sealants, Specifications for
24s.	C1306-95	Hydrostatic Pressure Resistance of a Liquid-Applied Waterproofing Membrane, Standard Test Method for
25.	D1527-96a	Acrylonitrile-Butadiene-Styrene (ABS), Schedules 40 and 80
26.	D1785-96b	Poly (Vinyl Chloride) (PVC) Plastic Pipe, Schedules 40, 80 and 120, Specification for
27.	D2104-96	Standard Specifications for Polyethylene (PE) Plastic Pipe, Schedule 40
28.	D2235-96a	Standard Specifications for Solvent Cement for Acrylonitrile-Butadiene-Styrene (ABS) Plastic Pipe and Fittings
29.	D2239-96a	Polyethylene (PE) Plastic Pipe (SIDR-PR) Based on Controlled Inside Diameter, Specification for
30.	D2241-96b	Standard Specification for Poly (Vinyl Chloride) (PVC) Plastic Pipe (SDR-Series)
31.	D2282-96a	Acrylonitrile-Butadiene-Styrene (ABS) Plastic Pipe (SDR-PR), Specification for
32.	D2321-89	Underground Installation of Thermoplastic Pipe for Sewers and Other Gravity-Flow Applications, Practice for
33.	D2447-95	Polyethylene (PE) Plastic Pipe, Schedules 40 and 80, Based on Outside Diameter, Specification for
34.	D2464-96a	Threaded Poly (Vinyl Chloride) (PVC) Plastic Pipe Fittings, Schedule 80, Specification for
35.	D2466-97	Poly (Vinyl Chloride) (PVC) Plastic Pipe Fittings, Schedule 40, Specification for
36.	D2467-96a	Socket-Type Poly (Vinyl Chloride) (PVC) Plastic Pipe Fittings, Schedule 80, Specification for

Table 81.20-5 (Continued)

		American Society for Testing and Materials 100 Barr Harbor Drive West Conshohocken, Pennsylvania 19428-2959 Phone: (610) 832-9585 Web page: www.astm.org
ASTM	Standard Reference Number	Title
37.	D2468-96a	Acrylonitrile-Butadiene-Styrene (ABS), Plastic Pipe Fittings, Schedule 40, Specification for
38.	D2564-96a	Solvent Cements for Poly (Vinyl Chloride) (PVC) Plastic Systems, Specification for
39.	D2609-97	Plastic Insert Fittings for Polyethylene (PE) Plastic Pipe, Specification for
40.	D2657-97	Heat Fusion Joining of Polyolefin Pipe and Fittings, Standard Practice of
41.	D2661-97a	Acrylonitrile-Butadiene-Styrene (ABS) Schedule 40 Plastic Drain, Waste, and Vent Pipe and Fittings, Specification for
42.	D2662-96a	Polybutylene (PB) Plastic Pipe (SIDR-PR), Based on Controlled Inside Diameter, Specification for
43.	D2665-97a	Poly (Vinyl Chloride) (PVC) Plastic Drain, Waste, and Vent Pipe and Fittings, Specification for
46.	D2680-95a	Acrylonitrile-Butadiene-Styrene (ABS) and Poly (Vinyl Chloride) (PVC) Composite Sewer Piping, Specification for
47.	D2683-98	Socket-Type Polyethylene Fittings for Outside Diameter-Controlled Polyethylene Pipe and Tubing, Specification for
48.	D2729-96a	Poly (Vinyl Chloride) (PVC) Sewer Pipe and Fittings, Specification for
49.	D2737-96a	Polyethylene (PE) Plastic Tubing, Specification for
50.	D2751-96a	Acrylonitrile-Butadiene-Styrene (ABS) Sewer Pipe and Fittings, Specification for
51.	D2774-94	Underground Installation of Thermoplastic Pressure Piping, Standard Practice for
52.	D2846/D2846M-97	Chlorinated Poly (Vinyl Chloride) (CPVC) Plastic Hot- and Cold-Water Distribution Systems, Specification for
53.	D2852-95	Styrene-Rubber (SR) Plastic Drain Pipe and Fittings, Specification for
54.	D2855-96	Making Solvent-Cemented Joints with Poly (Vinyl Chloride) (PVC) Pipe and Fittings, Practice for
55.	D3000-95a	Polybutylene (PB) Plastic Pipe (SDR-PR) Based on Outside Diameter, Specification for
56.	D3034-97	Type PSM Poly (Vinyl Chloride) (PVC) Sewer Pipe and Fittings, Specification for
57.	D3035-95	Polyethylene (PE) Plastic Pipe (SDR-PR) Based on Controlled Outside Diameter, Specification for
57s.	D3138-95	Solvent Cements for Transition Joints Between Acrylonitrile-Butadiene-Styrene (ABS) and Poly(Vinyl Chloride) (PVC) Non-Pressure Piping Components, Specifications for
58.	D3139-96a	Joints for Plastic Pressure Pipes Using Flexible Elastomeric Seals, Specification for
59.	D3140-90	Flaring Polyolefin Pipe and Tubing, Practice for
60.	D3212-96a	Joints for Drain and Sewer Plastic Pipes Using Flexible Elastomeric Seals, Specification for
61.	D3261-97	Butt Heat Fusion Polyethylene (PE) Plastic Fittings for Polyethylene (PE) Plastic Pipe and Tubing, Specification for
62.	D3309-96a	Polybutylene (PB) Plastic Hot- and Cold-Water Distribution Systems, Specification for
63.	D3311-94	Drain, Waste, and Vent (DWV) Plastic Fittings Patterns, Specification for
64.	D4068-96	Chlorinated Polyethylene (CPE) Sheeting for Concealed Water-Containment Membrane, Standard Test Method for
65.	D4491-89	Water Permeability of Geotextile by Permittivity, Standard Test Method for
66.	D4533-91	Trapezoid Tearing Strength of Geotextiles, Standard Test Method for
67.	D4632-91	Grab Breaking Load and Elongation of Geotextiles, Standard Test Method for
68.	D4751-87	Determining the Apparent Opening Size of a Geotextile, Standard Test Method for
69.	D4833-88	Index Puncture Resistance of Geotextile, Geomembranes, and Related Products, Standard Test Methods for
70.	F402-93	Safe Handling of Solvent Cements, Primers and Cleaners Used for Joining Thermoplastic Pipe and Fittings, Practice for
71.	F405-97	Corrugated Polyethylene (PE) Tubing and Fittings, Specification for

Table 81.20-5 (Continued)

		American Society for Testing and Materials 100 Barr Harbor Drive West Conshohocken, Pennsylvania 19428-2959 Phone: (610) 832-9585 Web page: www.astm.org
ASTM	Standard Reference Number	Title
72.	F409-97	Thermoplastic Accessible and Replaceable Plastic Tube and Tubular Fittings, Specification for
73.	F437-96a	Threaded Chlorinated Poly (Vinyl Chloride) (CPVC) Plastic Pipe Fittings, Schedule 80, Specification for
74.	F438-97	Socket-Type Chlorinated Poly (Vinyl Chloride) (CPVC) Plastic Pipe Fittings, Schedule 40, Specification for
75.	F439-97	Socket-Type Chlorinated Poly (Vinyl Chloride) (CPVC) Plastic Pipe Fittings, Schedule 80, Specification for
76.	F441/F441M-97	Chlorinated Poly (Vinyl Chloride) (CPVC) Plastic Pipe, Schedules 40 and 80, Specification for
77.	F442/F442M-97	Chlorinated Poly (Vinyl Chloride) (CPVC) Plastic Pipe (SDR-PR), Specification for
78.	F477-96a	Elastomeric Seals (Gaskets) for Joining Plastic Pipe, Specification for
78e.	F492-95	Propylene and Polypropylene (PP) Plastic-Lined Ferrous Metal Pipe Fittings
79.	F493-97	Solvent Cements for Chlorinated Poly (Vinyl Chloride) (CPVC) Plastic Pipe and Fittings, Specification for
80.	F628-97a	Acrylonitrile-Butadiene-Styrene (ABS) Schedule 40 Plastic Drain, Waste, and Vent Pipe with a Cellular Core, Specification for
81.	F656-96a	Primers for Use in Solvent Cement Joints of Poly (Vinyl Chloride) (PVC) Plastic Pipe and Fittings, Specification for
81e.	F679-95	Poly (Vinyl Chloride) (PVC) Large-Diameter Plastic Gravity Sewer Pipe and Fittings
81m.	F789-95a	Type PS-46 and Type PS-115 PVC Plastic Gravity Flow Sewer Pipe and Fittings
81s.	F794-97	Poly (Vinyl Chloride) (PVC) Profile Gravity Sewer Pipe and Fittings Based on Controlled Inside Diameter
82.	F810-93	Smoothwall Polyethylene (PE) Pipe for Use in Drainage and Waste Disposal Absorption Fields, Specification for
83.	F845-96	Plastic Insert Fittings for Polybutylene (PB) Tubing, Specification for
84.	F876-97	Crosslinked Polyethylene (PEX) Tubing, Specification for
85.	F877-97a	Crosslinked Polyethylene (PEX) Plastic Hot- and Cold-Water Distribution Systems, Specification for
86.	F891-97	Coextruded Poly (Vinyl Chloride) (PVC) Plastic Pipe With a Cellular Core, Specification for
87.	F949-96a	Poly (Vinyl Chloride) (PVC) Corrugated Sewer Pipe With a Smooth Interior and Fittings
88.	F1281-98	Crosslinked Polyethylene / Aluminum / Crosslinked Polyethylene (PEX-AL-PEX) Pressure Pipe
89.	F1282-97	Polyethylene / Aluminum / Polyethylene (PE-AL-PE) Composite Pressure Pipe
90.	F1336-93	Poly (Vinyl Chloride) (PVC) Gasketed Sewer Fittings
91.	F1807-98A	Metal Insert Fittings Utilizing a Copper Crimp Ring for SDR9 Cross-linked Polyethylene (PEX) Tubing
92.	F1866-98	Poly (Vinyl Chloride) (PVC) Plastic Schedule 40 Drainage and DWV Fabricated Fittings, Specifications for

Table 81.20-6

<b>AWS</b>		<b>American Welding Society 550 N.W. LeJune Road Miami, Florida 33126</b>
<b>Standard Reference Number</b>	<b>Title</b>	
AWS A5.8-92	Filler Metals for Brazing Welding, Specification for	

Table 81.20-7

<b>AWWA</b>		<b>American Water Works Association Data Processing Department 6666 West Quincy Avenue Denver, Colorado 80235</b>
<b>Standard Reference Number</b>	<b>Title</b>	
1. C110/A21.10-95	American National Standard for Ductile-Iron and Gray-Iron Fittings, 3 in. through 48 in., for Water and Other Liquids	
2. C111/A21.11-95	American National Standard for Rubber-Gasket Joints for Ductile-Iron Pressure Pipe and Fittings	
3. C115/A21.15-94	American National Standard for Flanged Ductile-Iron Pipe with Ductile-Type Iron or Gray-Iron Pipe Threaded Flanges	
4. C151/A21.51-96	American National Standard for Ductile-Iron Pipe, Centrifugally Cast for Water	
5. C153/A21.53-94	American National Standard for Ductile-Iron Compact Fittings, 3 in. through 16 in., for Water and Other Liquids	
5e. C651-92	Water Mains, Disinfecting	
6. C700-95	Cold Water Meters - Displacement Type with Bronze Main Case (w/ 1991 Addendum)	
7. C701-88	Cold Water Meters - Turbine Type for Customer Service	
8. C702-92	Cold Water Meters - Compound Type	
9. C704-92	Cold Water Meters - Propeller Type for Main Line Applications	
10. C706-96	Cold Water Meters, Direct-Reading, Remote-Registration Systems for	
11. C707-82(R92)	Cold Water Meters, Encoder-Type, Remote-Registration Systems for	
12. C708-96	Cold Water Meters - Multi-Jet Type	
13. C710-95	Cold Water Meters, Displacement Type - Plastic Main Case (w/1991 Addendum)	
14. C900-89	American Standard for Polyvinyl Chloride (PVC) Pressure Pipe, 4 in. through 12 in., for Water Distribution (w/1992 Addendum)	
15. C906-90	Polyethylene Pressure Pipe and Fittings, 4 in. through 63 in., for Water Distribution	

Table 81.20-7e

<b>CAN/CSA</b>		<b>Canadian Standards Association 178 Rexdale Boulevard Rexdale (Toronto), Ontario, Canada M9W 1R3</b>
<b>Standard Reference Number</b>	<b>Title</b>	
1. B64-94	Backflow Preventers and Vacuum Breakers	
2. B125-93	Plumbing Fittings	
3. B137.9-98	Polyethylene / Aluminum / Polyethylene Composite Pressure Pipe Systems	
4. B137.10-98	Crosslinked Polyethylene /Aluminum / Crosslinked Polyethylene Composite Pressure Pipe Systems	
5. B181.1-96	ABS Drain, Waste, and Vent Pipe and Pipe Fittings	
6. B181.2-96	PVC Drain, Waste, and Vent Pipe and Pipe Fittings	



Table 81.20-8

		<b>Cast Iron Soil Pipe Institute 5959 Shallowford Road, Suite 419 Chattanooga, Tennessee 37421 Web page: www.cispi.org</b>
	<b>Standard Reference Number</b>	<b>Title</b>
1.	301-97	Hubless Cast Iron Soil Pipe and Fittings for Sanitary and Storm Drain, Waste, and Vent Piping Applications, Standard Specification for
2.	310-97	Coupling for Use in Connection with Hubless Cast Iron Soil Pipe and Fittings for Sanitary and Storm Drain, Waste, and Vent Piping Applications, Specification for

Table 81.20-9

		<b>Factory Mutual Research Corp. 1151 Boston-Providence Turnpike Norwood, Massachusetts 02062</b>
	<b>Standard Reference Number</b>	<b>Title</b>
	1680	Couplings used in Hubless Cast Iron Systems for Drain, Waste or Vent, Sewer, Rainwater or Storm Drain Systems Above and Below Ground, Industrial/Commercial and Residential, January 1989

Table 81.20-10

		<b>Manufacturers Standardization Society of the Valve and Fittings Industry, Inc. 127 Park Street, N.E. Vienna, Virginia 22180</b>
	<b>Standard Reference Number</b>	<b>Title</b>
	SP-103	Wrought Copper and Copper Alloy Insert Fittings for Polybutylene Systems, 1995 Edition

Table 81.20-10m

		<b>National Fire Protection Association 11 Tracy Drive Avon, MA 02322-9908</b>
	<b>Standard Reference Number</b>	<b>Title</b>
	NFPA 13D-1999	Installation of Sprinkler Systems in One- and Two-Family Dwellings and Manufactured Homes

Table 81.20-11

		<b>NSF International 789 Dixboro Road P.O. Box 130140 Ann Arbor, Michigan 48113-0140 Phone: (800) 673-6275 Web page: www.nsf.org</b>
	<b>Standard Reference Number</b>	<b>Title</b>
1.	Standard 14-99	Plastic Piping Compounds and Related Materials
2.	Standard 40-99	Residential Wastewater Treatment Systems
3.	Standard 41-98	Non-Liquid Saturated Treatment Systems
4.	Standard 44-98	Residential Cation Exchange Water Softeners
5.	Standard 51-1997	Food Equipment Materials
6.	Standard 61-2001	Drinking Water System Components Health Effects

Table 81.20-12

STI	
Steel Tank Institute 570 Oakwood Road Lake Zurich, Illinois 60047	
Standard Reference Number	Title
STI-P <sub>3</sub>	External Corrosion Protection of Underground Steel Storage Tanks, Specifications and Manual for, 1996 edition

Table 81.20-13

UL	
Underwriters Laboratories Inc. 333 Pfingsten Road Northbrook, Illinois 60062	
Standard Reference Number	Title
1. Standard 58-86	Steel Underground Tanks for Flammable and Combustible Liquids
2. Standard 1746-89	External Corrosion Protection Systems for Steel Underground Storage Tanks

**History:** Cr. Register, April, 2000, No. 532, eff. 7-1-00; r. (2), renum. (3) to be (2) and am., r. and recr. Table 81.20-2, cr. Tables 81.20-3e, 81.20-7e and 81.20-10m, am. Tables 81.20-4 to 81.20-8 and 81.20-11, r. Table 81.20-14, Register, December, 2000, No. 540, eff. 1-1-01; correction in (1) made under s. 13.93 (2m) (b) 7., Stats., Register, December, 2000, No. 540; CR 02-002: r. and recr. Register April 2003 No. 568, eff. 5-1-03; CR 02-129: am Table 81.20-8 Register January 2004 No. 577, eff. 2-1-04.

## Chapter Comm 82

### DESIGN, CONSTRUCTION, INSTALLATION, SUPERVISION, MAINTENANCE AND INSPECTION OF PLUMBING

Comm 82.01 Scope.  
Comm 82.015 Purpose.  
Comm 82.03 Application.

#### Subchapter I — Intent and Basic Requirements

Comm 82.10 Basic plumbing principles.

#### Subchapter II — Administration and Enforcement

Comm 82.20 Plan review and cross connection control assembly registration.  
Comm 82.21 Testing and maintenance.

#### Subchapter III — Drain and Vent Systems

Comm 82.30 Sanitary drain systems.

Comm 82.31 Vents and venting systems.  
Comm 82.32 Traps and direct fixture connections.  
Comm 82.33 Indirect and local waste piping.  
Comm 82.34 Wastewater treatment devices.  
Comm 82.35 Cleanouts.  
Comm 82.36 Storm and clear water drain systems.  
Comm 82.37 Sanitation facilities and campgrounds.  
Comm 82.38 Discharge points.

#### Subchapter IV — Water Supply Systems

Comm 82.40 Water supply systems.

**Note:** Sections ILHR 82.01 to 82.25, 82.15 and 82.17 to 82.25 as they existed on February 28, 1985 were repealed and new sections ILHR 82.01 to 82.36 and 82.51 and 82.60 were created effective March 1, 1985. Chapter ILHR 82 was renumbered chapter Comm 82 under s. 13.93 (2m) (b) 1., Stats. and corrections made under s. 13.93 (2m) (b) 7., Stats., Register, February, 1997, No. 494.

**Comm 82.01 Scope.** The provisions of this chapter apply uniformly to the design, construction, installation, supervision, maintenance and inspection of plumbing, including but not limited to sanitary and storm drainage, water supplies, wastewater treatment, and dispersal or discharge for buildings, except for POWTS systems as regulated by ch. Comm 83.

**History:** Cr. Register, February, 1985, No. 350, eff. 3-1-85; CR 02-002: am. Register April 2003 No. 568, eff. 5-1-03; CR 02-129: am. Register January 2004 No. 576, eff. 2-1-04.

**Comm 82.015 Purpose.** Pursuant to s. 145.02, Stats., the purpose of this chapter is to provide that all plumbing in connection with buildings and facilities in the state, including buildings owned by the state or any political subdivision thereof, shall be safe, sanitary and such as to safeguard the public health and the waters of the state.

**History:** CR 02-002: cr. Register April 2003 No. 568, eff. 5-1-03.

**Comm 82.03 Application.** (1) The provisions of this chapter are not retroactive, unless specifically stated otherwise in the rule.

(2) Pursuant to s. 145.13, Stats., this chapter is uniform in application and a municipality may not enact an ordinance for the design, construction, installation, supervision, maintenance and inspection of plumbing which is more stringent than this chapter, except as specifically permitted by rule.

**History:** Cr. Register, February, 1985, No. 350, eff. 3-1-85; CR 02-002: renum. to be (1), cr. (2) Register April 2003 No. 568, eff. 5-1-03.

#### Subchapter I — Intent and Basic Requirements

**Comm 82.10 Basic plumbing principles.** This chapter is founded upon basic principles of environmental sanitation and safety through properly designed, installed and maintained plumbing systems. Some of the details of plumbing construction may vary, but the basic sanitary and safety principles desirable and necessary to protect the health of people are the same. As interpretations may be required and as unforeseen situations arise which are not specifically addressed, the following intent statements and basic requirements shall be used to evaluate equivalency where applicable:

(1) **INTENT.** (a) Plumbing in connection with all buildings, public and private, intended for human occupancy, shall be installed and maintained in such a manner so as to protect the health, safety and welfare of the public or occupants and the waters of the state.

(b) Plumbing fixtures, appliances and appurtenances, whether existing or to be installed, shall be supplied with water in sufficient volume and at pressures adequate to enable the fixtures, appliances and appurtenances to function properly and efficiently at all times and without undue noise under normal conditions of use. Plumbing systems shall be designed and adjusted to use the minimum quantity of water consistent with proper performance and cleaning.

(c) Devices for heating and storing water in pressure vessels or tanks shall be so designed and installed as to prevent dangers of explosion or overheating.

(d) Drain systems shall be designed, constructed and maintained so as to conduct the wastewater or sewage efficiently and shall have adequate cleanouts.

(e) The drain systems shall be so designed as to provide an adequate circulation of air in all pipes and no danger of siphonage, aspiration or forcing of trap seals under conditions of ordinary use.

(f) A plumbing system shall be of durable material, free from defective workmanship, and designed and constructed so as to provide satisfactory service for its reasonable expected life.

(g) Proper protection shall be provided to prevent contamination of food, water, sterile goods and similar materials by back flow of wastewater.

(h) All plumbing fixtures shall be installed so as to provide adequate spacing and accessibility for the intended use and cleaning.

(2) **BASIC REQUIREMENTS.** (a) Every building intended for human occupancy shall be provided with an adequate, safe and potable water supply.

(b) To fulfill the basic needs of sanitation and personal hygiene, each dwelling connected to a POWTS or public sewer shall be provided with at least the following plumbing fixtures: one water closet, one wash basin, one kitchen sink and one bathtub or shower, except a system or device recognized under ch. Comm 91 may be substituted for the water closet. All other structures for human occupancy shall be equipped with sanitary facilities in sufficient numbers as specified in chs. Comm 61 to 65.

(c) Hot or tempered water shall be supplied to all plumbing fixtures that normally require hot or tempered water for proper use and function.

(d) Where plumbing fixtures exist in a building that is not connected to a public sewer system, suitable provision shall be made for treating, recycling, dispersing or holding the wastewater.

(e) Plumbing fixtures shall be made of durable, smooth, non-absorbent and corrosion resistant material, and shall be free from concealed fouling surfaces.

**History:** Cr. Register, February, 1985, No. 350, eff. 3-1-85; correction in (3) made under s. 13.93 (2m) (b) 7., Stats.; am. (2), Register, August, 1991, No. 428, eff.

9-1-91; am. (3), Register, March, 1992, No. 435, eff. 4-1-92; r. (7) and renum. (8) to (15) to be (7) to (14), Register, February, 2000, No. 530, eff. 3-1-00; am. (2), (7) and (12), r. and recr. (3) and r. (14), Register, April, 2000, No. 532, eff. 7-1-00; CR 01-139: am. (3) Register June 2002 No. 558, eff. 7-1-02; CR 02-002: r. and recr. Register April 2003 No. 568, eff. 5-1-03.

## Subchapter II — Administration and Enforcement

**Comm 82.20 Plan review and cross connection control assembly registration.** (1) **GENERAL.** Plans and specifications shall be submitted to the department or to an approved agent municipality for review in accordance with pars. (a) and (b). All registrations for cross connection control assemblies shall be submitted to the department in accordance with par. (c).

**Note:** The department forms required in this chapter are available from the Safety and Buildings Division at P.O. Box 7162, Madison, WI 53707-7162, or at telephone (608) 266-3151 and (608) 264-8777 (TTY), or at the Safety and Buildings' web site at [www.commerce.state.wi.us](http://www.commerce.state.wi.us).

(a) **Department review.** When review is required, regardless of where the installation is to be located, written approval for the plans shall be obtained prior to installation of the work. The following types of installations shall be submitted to the department for review:

1. All types of installations listed in Table 82.20-1.
2. Treatment systems intended to be used to comply with the plumbing treatment standards as listed in Table 82.70-1, unless the treatment system is otherwise approved for that use as specified under s. Comm 82.20 (12), 84.10 or 84.50.

(b) **Department or agent municipality review.** 1. Plumbing plans and specifications for the types of plumbing installations listed in Table 82.20-2 shall be submitted for review to an agent municipality, if the installation is to be located within the agent municipality or to the department, if the installation is not to be located within an agent municipality. A municipality shall be designated as an agent municipality in accordance with sub. (2). Written approval for the plumbing plans shall be obtained prior to installation of the plumbing.

**Note:** The number of plumbing fixtures to be submitted and reviewed by an agent municipality is a subject of local ordinances.

2. Plan review and approval of one- and 2-family dwellings. Review and approval of plumbing plans for one- and 2-family dwellings shall be in accordance with the provisions specified in s. Comm 20.09.

(c) **Cross connection control assembly registration.** The initial installation of each reduced pressure principle backflow preventer, back siphonage backflow vacuum breaker, reduced pressure detector backflow preventer, or pressure vacuum breaker, shall meet all of the following:

1. a. Except as provided under subd. 1. b., for initial installation in any building or facility, each assembly covered under this paragraph shall be registered with the department.
- b. Plan review approval for a cross connection control assembly issued prior to May 1, 2003 is considered in compliance with this paragraph.
2. For each assembly covered under this paragraph registration shall be submitted prior to the initial test.

**Table 82.20-1**  
**SUBMITTALS TO DEPARTMENT**

Type of Plumbing Installation	
1.	Except for direct replacement, all plumbing, new installations, additions and alterations, regardless of the number of plumbing fixtures involved, to be installed in hospitals, nursing homes and ambulatory surgery centers. <sup>b</sup>
2.	Plumbing, new installations, additions and alterations involving 16 or more plumbing fixtures, to be installed in connection with buildings owned by a metropolitan or sanitary sewer district. <sup>a</sup>
3.	Plumbing, new installations, additions and alterations involving 16 or more plumbing fixtures, to be installed in connection with buildings owned by the state. <sup>a</sup>
4.	Alternate and experimental plumbing systems.
5.	For installation in health care and related facilities, reduced pressure principle backflow preventers and reduced pressure detector backflow preventers.
6.	For installation in health care and related facilities, pressure vacuum breaker assembly.
7.	For installation in health care and related facilities, back siphonage backflow vacuum breaker.
8.	Subsurface storm water or subsurface clearwater dispersal plumbing systems in connection with public buildings.
9.	Plumbing water treatment systems, other than POWTS, designed to treat water for compliance with Table 82.70-1. <sup>c</sup>

<sup>a</sup> Water heaters, floor drains, storm inlets, roof drains and hose bibbs are to be counted as plumbing fixtures.

<sup>b</sup> For hospitals, nursing homes and ambulatory care surgery centers, registration for cross connection control devices as specified under s. Comm 82.20 (1) is included as a part of plan approval.

<sup>c</sup> For a product approved under s. Comm 84.10 or 84.50, the installation of such product does not constitute a system.

**Table 82.20-2**  
**SUBMITTALS TO DEPARTMENT OR**  
**AGENT MUNICIPALITY**

Type of Plumbing Installation	
1.	Except for direct replacement, new installations, additions and alterations to drain systems, vent systems, water service systems, and water distribution systems involving 16 or more plumbing fixtures to be installed in connection with public buildings. <sup>a,b</sup>
2.	Grease interceptors to be installed for public buildings.
3.	Garage catch basins, carwash interceptors and oil interceptors to be installed for public buildings and facilities.
4.	Sanitary dump stations.
5.	Piping designed to serve as private water mains.
6.	Water supply systems and drain systems to be installed for mobile home parks and campgrounds. <sup>c</sup>
7.	Piping designed to serve as private interceptor main sewers greater than 4 inches in diameter when sized for gravity flow as specified in Table 82.30-1.
8.	Chemical waste systems regardless of the number of plumbing fixtures. <sup>c</sup>

<sup>a</sup> Water heaters, floor drains, storm inlets, roof drains and hose bibbs are to be counted as plumbing fixtures.

<sup>b</sup> For the purpose of plan submittal, public buildings do not include zero-lot-line row houses where each living unit is served by an individual water service and an individual building sewer.

<sup>c</sup> Only agent municipalities which are cities of the first class may review these types of installations.

**(2) AGENT MUNICIPALITIES.** The department may designate to an approved municipality the authority to review and approve plumbing plans and specifications for those plumbing installations to be located within the municipality's boundary limits and which require approval under sub. (1) (b).

(a) An agent municipality shall employ at least 2 full time plumbing inspectors who have been qualified by the department.

1. The primary duties of the plumbing inspectors shall include plumbing plan review.

2. The plumbing inspectors shall be Wisconsin licensed master or journeyman plumbers.

Note: See Appendix for listing of agent municipalities.

(b) An agent municipality may waive its jurisdiction for plan review and approval for any project, in which case plans shall be submitted to the department for review and approval.

(c) Agent municipalities may set by ordinance the fees for plan review services.

**(3) PRIORITY PLAN REVIEW.** An appointment may be made with the department to facilitate the examination of plans in less than the normal processing time. Complete plans along with the fee specified in s. Comm 2.61 (3), shall be submitted to the department. The plans shall comply with all of the provisions of this section.

**(4) PLANS AND SPECIFICATIONS.** (a) At least 2 sets of plans and one copy of specifications which are clear, legible and permanent copies shall be submitted for examination and approval.

(b) All plans submitted for approval shall be accompanied by sufficient data and information for the department to determine if the installation and its performance will meet the requirements of chs. Comm 81 to 84.

1. Information to accompany the plans shall include the location or address of the installation and the name of the owner.

2. Plans proposing the installation, creation or extension of a private sanitary building sewer or a sanitary private interceptor main sewer which is to discharge to a municipal treatment facility shall:

a. Be accompanied by a letter from the appropriate designated planning or management agency indicating conformance with an approved areawide water quality management plan under ch. NR 121; and

b. Not be approved, if the municipality is ineligible for sanitary sewer extension approvals under s. NR 110.05.

Note: For plans proposing the installation, creation or extension of a private interceptor main sewer which is to discharge to a municipal treatment facility, see also ch. NR 121.

3. Except as provided in subd. 4., plans proposing the installation of a building sewer for new construction which is to discharge to a municipal treatment facility shall:

a. Be accompanied by a letter from either the appropriate designated management agency or sanitary district indicating conformance with an approved areawide water quality management plan; and

b. Not be approved, if the municipality is ineligible for sanitary sewer extension approvals under s. NR 110.05.

4. Plans proposing the installation of a building sewer for new construction which is to discharge to a municipal treatment facility shall not be required to comply with subd. 3., if:

a. The proposed installation is served by an existing building sewer which extends from the lot line to the public sewer and the proposed installation does not exceed the capacity of the existing building sewer or sewers; or

b. The plans indicate that a drainage load of not more than 54 drainage fixture units will be discharged through the building sewer.

Note: See Appendix for listing of water quality management agencies.

(c) Plumbing plans, index sheets and specifications for a plumbing system submitted for review and approval shall be signed in accordance with any of the following methods:

1. A Wisconsin registered architect, engineer or plumbing designer shall sign and seal or stamp all plans and accompanying specifications in accordance with ch. A-E 2.

2. A master plumber, master plumber-restricted service, master plumber-restricted appliance or a utility contractor shall sign and date all plumbing plans and accompanying specifications as provided under s. 145.06, Stats. Each sheet of plans and specifications submitted shall be signed and dated and shall include the valid Wisconsin license number of the individual responsible for the installation. Where more than one sheet is bound together into one volume, only the title sheet or index sheet shall be signed and dated by the individual responsible for the installation. The signed title or index sheet shall clearly identify all of the other sheets in the volume.

3. A pump installer shall sign and date all plumbing plans and accompanying specifications for which the individual is responsible for the installation. Each sheet of plans and specifications submitted shall be signed and dated and shall include the valid Wisconsin license number of the individual responsible for the installation. Where more than one sheet is bound together into one volume, only the title sheet or index sheet shall be signed and dated by the individual responsible for the installation. The signed title or index sheet shall clearly identify all of the other sheets in the volume.

(d) 1. When requesting approval of an experimental plumbing system, all of the following shall be submitted:

a. At least 2 sets of plans signed in accordance with par. (d) and detailing the system installation for each site.

b. A letter of consent from the site or system owner of the installation. The letter shall acknowledge that the owner has received and read a copy of the experimental plumbing system submittal and is in agreement with all requirements listed within this subdivision.

c. Any additional information as requested by the department.

2. The registered architect, engineer, designer or master plumber responsible for the design of the experimental plumbing system shall, upon completion, certify in writing to the department that the installation is in compliance with the approved plans, specifications and data.

3. Onsite inspections shall be performed by the department at time intervals as specified by the department, but not less than once a year. Time intervals shall be included as conditions of approval. An inspection report shall be written. The department may assess a fee for each inspection.

Note: Refer to ch. Comm 2 for applicable fees.

4. No later than five years after the date of the completed installation the department may perform one of the following:

a. Order the removal of the experimental plumbing system.

b. Issue an alternate approval as specified in sub. (12) (a).

c. Provide an extension of the experiment with conditions.

5. If an experimental plumbing system is subsequently codified in chs. Comm 82 and 84, or ch. 145, Stats., the requirements as specified in subs. 3. and 4. do not apply.

**(5) PLAN REVIEW.** Except as provided in sub. (12), the department shall review and make a determination on an application for plan review within 15 days of receiving the required information and fees.

(a) *Conditional approval.* If, upon review, the department determines that the plans substantially conform to the provisions of chs. Comm 82 to 84, a conditional approval, in writing, shall be granted. All noncode complying conditions stated in the conditional approval shall be corrected before or during installation.

(b) *Denial of approval.* If, upon review, the department determines that the plans do not substantially conform to the provisions of chs. Comm 82 to 84, the request of conditional approval shall be denied in writing.

**(6) EVIDENCE OF APPROVAL.** The plumber responsible for the installation of the plumbing shall keep at the construction site at

least one set of plans bearing the department's or the agent municipality's stamp of approval and at least one copy of specifications. The plans and specifications shall be open to inspection by an authorized representative of the department.

**(7) FEES.** Fees for plumbing plan review and petition for variance shall be submitted in accordance with ss. Comm 2.64 and 2.52.

**(8) REVISIONS.** All changes or modifications, which involve the provisions of chs. Comm 82 to 84, made to plumbing plans and specifications, which have been granted approval under sub. (1), shall be submitted to the department or agent municipality for examination. All changes and modifications shall be approved in writing by the department or agent municipality prior to installation of the plumbing.

**(9) REVOCATION OF APPROVAL.** The department may revoke any approval, issued under the provisions of this chapter, for any false statements or misrepresentation of facts on which the approval was based.

**(10) DEPARTMENT LIMITATION AND EXPIRATION OF APPROVAL.**  
**(a)** A conditional approval of a plan by the department shall not be construed as an assumption by the department of any responsibility for the design; and the department does not hold itself liable for any defects in construction, nor for any damages that may result from the specific installation.

**(b)** Plan approval by the department or its authorized representative shall expire 2 years after the date indicated on the approval letter, if construction has not commenced within that 2 year period.

**(11) PETITION FOR VARIANCE.** **(a) Procedure.** The department shall consider and may grant a variance to a provision of this chapter in accordance with ch. Comm 3.

**Note:** Chapter Comm 3 requires the submittal of a petition for variance form (SBD-9890) and a fee, and that an equivalency is established in the petition for variance that meets the intent of the rule being petitioned. Chapter Comm 3 also requires the department to process regular petitions within 30 business days and priority petitions within 10 business days.

**Note:** Form SBD-9890 is available on request at no charge from the department at the Safety and Buildings Division, P.O. Box 2509, Madison WI 53701-2509, telephone (608) 266-1818, S&B web address: <http://www.commerce.state.wi.us/SB/SB-Forms.html/>.

**(b) Petition processing time.** Except for priority petitions, the department shall review and make a determination on a petition for variance within 30 business days of receipt of all calculations, documents and fees required to complete the review. The department shall process priority petitions within 10 business days.

**Note:** The petition for variance form (SBD-8) is available from the Safety and Buildings Division, P. O. Box 7162, Madison, WI 53707.

**(12) ALTERNATE AND EXPERIMENTAL PLUMBING SYSTEM REVIEW AND APPROVAL.** The provisions of this chapter, ch. Comm 84 or ch. 145, Stats., are not intended to prevent the design and use of approved innovative plumbing systems.

**(a) Alternate plumbing systems.** The department may issue an approval of an alternate plumbing system if the system complies with the intent of chs. Comm 82 and 84, or ch. 145, Stats.

1. For an alternate plumbing system, before availability for statewide installation and use, an alternate plumbing system approval shall be issued. Concepts, plans, specifications and the documentation to support the system design shall be submitted to the department for review.

2. The department may require the submission of any information deemed necessary for review. Sufficient evidence shall be submitted to substantiate at least the following:

a. Assertions of function and performance.  
 b. Compliance with the intent of chs. Comm 82 and 84, or ch. 145, Stats.

3. The department shall review and make a determination on an application for alternate plumbing system within 3 months of receipt of all information and fees required to complete the review. Approval for an alternate plumbing system shall be issued by the department in writing.

4. The department may include specific conditions in issuing an approval for an alternate plumbing system, including an expiration date for the approval. A violation of any of the conditions under which an approval is issued shall constitute a violation of this chapter.

5. If upon review the department determines that an alternate plumbing system does not comply with the intent of chs. Comm 82 and 84, or ch. 145, Stats., the request for approval shall be denied in writing.

**(b) Experimental plumbing systems.** The department may issue an approval of an experimental plumbing system for the purpose of proving compliance with the intent of chs. Comm 82 and 84 and ch. 145, Stats.

1. For an experimental plumbing system, a separate approval shall be obtained for each system or project to be installed for the purpose of proving compliance with the intent of chs. Comm 82 and 84 and ch. 145, Stats. Approval for an experimental plumbing system shall be issued by the department in writing.

2. The department may require the submission of additional information deemed necessary for determining that the design meets the intent of chs. Comm 82 and 84 and ch. 145, Stats.

3. The department shall review and make a determination on an application for an experimental plumbing system within 6 months of receipt of all information and fees required to complete the review.

4. The department may include specific conditions in issuing an approval for an experimental plumbing system, including an expiration date for the approval. A violation of any of the conditions under which an approval is issued shall constitute a violation of this chapter.

5. Denial of an experimental plumbing system or project by the department shall be made in writing.

6. The department may establish parameters to limit the number of applications for review it will accept for experimental plumbing systems.

**(c) Modification.** If an approved alternate or experimental plumbing system is modified or additional assertions of function or performance are made, the approval shall be void, unless the system is resubmitted to the department for review and approval is granted.

**(d) Revocation of approval.** The department may revoke an approval issued under this section for any false statements or misrepresentations of facts or data on which the approval was based, or as a result of system failure.

**(e) Limitations.** An approval issued by the department for an alternate or experimental plumbing system may not be construed as an assumption of any responsibility for defects in design, construction or performance of any system nor for any damages that may result.

**(f) Fees.** Fees for the review of an alternate or experimental plumbing system under this section and any onsite inspections shall be submitted in accordance with ch. Comm 2.

**(13) CROSS CONNECTION CONTROL REGISTRATION.** **(a) Registration,** as specified in sub. (1) (c), shall be submitted in a format acceptable to the department.

**Note:** The forms required in this chapter are available from the Safety and Buildings Division, P.O. Box 7162, Madison, WI 53707-7162, or at telephone (608) 266-3151 and (608) 264-8777 (TTY), or at the Safety and Buildings' web site at [www.commerce.state.wi.us](http://www.commerce.state.wi.us).

**(b)** The form for registering cross connection control devices and assemblies with the department shall include at least all of the following information:

1. The building or facility name and address where the device or assembly is or will be installed.

2. The location of the cross connection control device or assembly within the building or facility.

3. A description of the cross connection control device or assembly including the size, model number, serial number and manufacturer.

4. The name of the owner or owner's agent submitting the registration form and contact information.

(c) Each registration form submitted shall be accompanied by the appropriate fee in accordance with s. Comm 2.645.

(d) Upon receipt of a completed registration form, the department shall issue written confirmation of registration including a department assigned identification number for each cross connection control device or assembly.

(e) Upon permanent removal or replacement of any reduced pressure principle backflow preventer, back siphonage backflow vacuum breaker, reduced pressure detector backflow preventer or pressure vacuum breaker, the owner shall notify the department in writing using a format acceptable to the department.

**(14) PENALTIES.** Penalties for violations of this chapter shall be assessed in accordance with s. 145.12, Stats.

**History:** Cr. Register, February, 1985, No. 350, eff. 3-1-85; am. (1) (intro.), r. and recr. Tables 82.20-1 and 82.20-2, r. (5), renum. (6) to (12) to be (5) to (11), cr. (5) (intro.) and (12), Register, May, 1988, No. 389, eff. 6-1-88; correction in (1) (b) 1. made under s. 13.93 (2m) (b) 7., Stats., Register, May, 1988, No. 389; am. (4) (c) 2. intro. and 4. a. and b., Register, February, 1991, No. 422, eff. 3-1-91; am. (4) (c) 3.a., Register, August, 1991, No. 428, eff. 9-1-91; am. (1) (intro.), (a), (4) (a) to (c) 1., (5) (a), (b) and Tables 82.20-1 and 82.20-2, renum. (4) (d) and (e) to be (4) (d) 1. a. and b. and am. (4) (d) 1. a., cr. (4) (d) 2., Register, February, 1994, No. 458, eff. 3-1-94; correction in (7) made under s. 13.93 (2m) (b) 7., Stats., Register, February, 1994, No. 458; corrections made under s. 13.93 (2m) (b) 7., Stats., Register, October, 1996, No. 490; am. Tables 82.20-1, 2, (1) (b) 2., Register, February, 1997, No. 494, eff. 3-1-97; correction in (13) made under s. 13.93 (2m) (b) 7., Stats., Register, February, 2000, No. 530; am. Tables 82.20-1 and 82.20-2, r. (4) (b), Register, July, 2000, No. 535, eff. 9-1-00; cr. (4) (e), r. and recr. (11) and (12), am. Table 82.20-1, Register, December, 2000, No. 540, eff. 1-1-01; CR 02-002: am. (1) (intro.) and Tables 82.20-1 and 82.20-2, r. and recr. (1) (a), r. (1) (b) 2. and (4) (d), renum. (1) (b) (intro.), and 1., (4) (c), (e) and (13) to be (1) (b) 1. and 2., (4) (b), (d) and (14) and am. (4) (b) (intro.) and 2. (intro.), cr. (1) (c), (4) (c) and (13) Register April 2003 No. 568, eff. 5-1-03; CR 02-129: am. (title), (1) (intro) and (c), and (13) (e) Register January 2004 No. 577, eff. 2-1-04.

**Comm 82.21 Testing and maintenance. (1) TESTING OF PLUMBING SYSTEMS.** Except as provided in par. (a), all new plumbing and all parts of existing systems which have been altered, extended or repaired shall be tested as specified in par. (d) to disclose leaks and defects before the plumbing is put into operation.

(a) *Waiver of testing.* 1. The testing of the plumbing shall not be required where the installation does not include the addition, replacement, alteration or relocation of any water distribution, drain or vent piping.

2. a. Field testing the installation of a storm building sewer and a storm private interceptor main sewer is not required.

b. The joints and connections to be employed for storm building sewer piping shall conform with s. Comm 84.40 (1) (a).

(b) *Local inspection.* Where the plumbing is installed in a municipality having a local inspector, the testing of the plumbing shall be done in the presence of a plumbing inspector, except as provided in subd. 1. b.

1. Notice of inspection. a. The plumber responsible for the installation shall notify the plumbing inspector in person, by telephone or in writing when the work is ready for inspection.

b. If the inspection is not made by the end of the normal business day following the day of notification, not including Saturday, Sunday or legal holidays, the plumber may proceed with the testing and the installation.

2. Preparations for inspection. When the installation is ready for inspection, the plumber shall make such arrangements as will enable the plumbing inspector to inspect all parts of the plumbing system. The plumber shall have present the proper apparatus and appliances for making the tests, and shall furnish such assistance as may be necessary in making the inspection.

3. Rough-in inspection. A rough-in inspection shall be made when the plumbing system is roughed-in and before fixtures are set. Except as provided in subd. 1., plumbing work shall not be closed in, concealed, or covered until it has been inspected and approved by the plumbing inspector and permission is granted to do so.

4. Final inspection. a. Upon completion of the plumbing installation and before final approval is given, the plumbing inspector shall inspect the work.

b. Municipalities may require that a final test be conducted in accordance with par. (d) 8. and that the final test, when required by the municipality, shall be observed by the plumbing inspector.

5. Reinspections. Whenever the plumbing official finds that the work or installation does not pass any initial test or inspection, the necessary corrections shall be made to comply with this chapter. The work or installation shall then be resubmitted for inspection to the plumbing inspector.

(c) *Inspection of one- and 2-family dwellings.* The inspection of plumbing installations for one- and 2-family dwellings shall be in accordance with ss. Comm 20.08 to 20.11.

(d) *Testing provisions.* 1. General. The testing of plumbing installations shall be conducted in accordance with this paragraph.

a. Equipment, material and labor for tests. All equipment, material and labor required for testing a plumbing system or part thereof shall be furnished by the plumber responsible for the installation.

b. Exposure of work. Except as provided in subds. 2. and 5., all new, altered, extended or replaced plumbing shall be left uncovered and unconcealed until it has been tested. Where the work has been covered or concealed before it is tested, it shall be exposed for testing.

2. Sanitary building sewer and sanitary private interceptor main sewer. A sanitary building sewer and a sanitary private interceptor main sewer shall be tested for leaks and defects with water or air before or after being covered in accordance with either subd. 2. a. or b. The test for leaks and defects may be applied to the entire building sewer or private interceptor main sewer or in sections. For the purposes of this subdivision, the testing of a building sewer or private interceptor main sewer is not required to include the manholes serving the sewer.

a. The building sewer or private interceptor main sewer shall be tested by insertion of a test plug at the point of connection with the public sewer. The sewer shall then be filled with water under a head of not less than 10 feet. The water level at the top of the test head of water shall not drop for at least 15 minutes.

b. The air test shall be made by attaching an air compressor testing apparatus to any suitable opening, and, after closing all other inlets and outlets to the system, forcing air into the system until there is a uniform gauge pressure of 3 pounds per square inch. This pressure shall be held without introduction of additional air for a period of at least 15 minutes.

3. Building drain. The entire building drain with all its branches, receptacles and connections shall be brought so far as practical to the surface or grade of the basement floor and shall be tested with water or air in accordance with subd. 7.

4. Drain and vent systems. The piping of a drain and vent systems, including conductors, shall be tested upon completion of the rough piping installation with water or air in accordance with subd. 7.

5. Private water mains and water services. Private water mains and water services shall be inspected before being covered. The private water mains and water services shall be tested and proven water tight under water pressure not less than the working pressure under which it is to be used. The water used for testing shall be obtained from a potable source of supply.

6. Water distribution system. The piping of a water distribution system shall be tested and proved water tight under a water pressure not less than the working pressure under which it is to be used. The water used for tests shall be obtained from a potable source of supply.

7. Test methods for drain and vent systems. A test for water tightness shall be applied to the entire drain and vent system at one time or to the entire system in sections after the rough piping has been installed in accordance with either subd. 7. a. or b.

a. If applied to the entire system, all openings in the piping shall be tightly closed, except the highest opening, and the system shall be filled with water to the point of overflow. If the system is tested in sections, each opening shall be tightly plugged except the highest opening of the section under test, and each section shall be filled with water, but a section shall not be tested with less than a 10 foot head of water. In testing successive sections, at least the upper 10 feet of the next preceding section shall be tested, so that no joint or pipe in the building, except the uppermost 10 feet of the system, is subjected to a test of less than a 10 foot head of water. The water shall be kept in the system or in the portion under test for at least 15 minutes before inspection starts. The system shall then be tight at all points.

b. The air test shall be made by attaching an air compressor testing apparatus to any suitable opening, and, after closing all other inlets and outlets to the system, forcing air into the system until there is a uniform gauge pressure of 5 pounds per square inch or sufficient to balance a column of mercury 10" in height. This pressure shall be held without introduction of additional air for a period of at least 15 minutes.

8. Final test. Where required by the local plumbing inspector, after the plumbing fixtures have been installed and the traps filled with water, the connections shall be tested and proved gas and watertight by either one of the methods specified in subd. 8. a. or b.

a. The smoke test shall be made by introducing a pungent, thick smoke, produced by one or more smoke machines, into the completed system. When the smoke appears at stack openings on the roof, the openings shall be closed and a pressure equivalent to a one inch water column shall be built and maintained for the period of the inspection.

b. The air test shall be made by attaching a gauge to any suitable opening and, after closing all other inlets and outlets in the system, adding air into the system until a pressure equivalent to a one inch water column exists. The pressure shall remain constant for at least a 5-minute test period without the introduction of additional air.

**(2) MAINTENANCE AND REPAIRS.** All plumbing systems, both existing and new, and all parts thereof, shall be maintained in a safe and sanitary condition. All devices or safeguards which are required by this chapter shall be maintained in good working order. The owner shall be responsible for the maintenance of plumbing systems.

(a) *Existing systems.* 1. Except as specified in subd. 2., any existing plumbing system shall be permitted to remain and maintenance continue if the maintenance is in accordance with the original system design and any of the following apply:

a. The plumbing system was installed in accordance with the code in effect at the time of installation.

b. The plumbing system conforms to the present code.

2. When a hazard to life, health or property exists or is created by an existing system, that system shall be repaired or replaced.

(b) *Fixtures replaced.* When an old or defective fixture is removed, to be replaced by a new fixture, and no other fixture or piping is to be added or remodeled, it is not necessary to reconstruct the drain or vent piping to make it conform to the provisions of this chapter, unless the drain or vent piping is in a defective condition. Where the existing drain or vent piping does not conform to the provisions of this chapter, the department may require the new fixtures to be provided with deep seal traps.

(c) *Reconstruction.* When old or defective plumbing is to be remodeled, additional fixtures installed, or the whole plumbing

system moved to another part of the building, the remodeled system shall be made to conform to this chapter.

(d) *Plumbing reused.* 1. Except as provided in subd. 2., plumbing materials removed and found to be in good condition, may be reused if such reuse is approved by the department or a local plumbing inspector. The owner of the building or facility in which the reused materials are to be installed shall provide written consent.

2. Water supply piping materials may only be reused when intended for uses having an equal or higher degree of hazard than the previous use as specified in Table 82.70-1.

(e) *Existing building sewers and drains.* Existing building sewers and drains may be used in connection with new buildings only when they are found on examination and test to conform to the requirements of this chapter governing building sewers and drains. If the existing work is found defective, the local or state inspector shall notify the owner of the changes necessary to make it conform to the requirements of this chapter.

(f) *Repairs.* All repairs to fixtures or piping shall be done in conformance with the provisions of this chapter, except repair clamps or bands may be used for emergency situations.

(g) *Demolition of structures.* When a structure is demolished or removed, all sanitary sewer, storm sewer and water supply connections shall be sealed and plugged in a safe manner.

(h) *Dead ends.* If a dead end is created in the removal of any part of a drain system, all openings in the drain system shall be properly sealed.

**(3) MAINTENANCE AND TESTING OF CROSS CONNECTION CONTROL DEVICES.** (a) The maintenance and performance testing requirements of this subsection apply to all cross connection control devices regardless of date of installation.

*Note:* For further clarification, see Table 82.21-1.

(b) 1. A performance test shall be conducted for the devices listed in Table 82.21-1 at all of the following intervals:

a. At the time of installation.

b. Immediately after repairs or alterations to the device have occurred.

c. At least annually.

2. The performance test shall be conducted using the appropriate test standard for the device as specified in Table 82.21-1.

3. A cross connection device performance test shall be conducted by an individual registered by the department in accordance with s. Comm 5.99.

4. a. The results of the cross connection device performance test shall be submitted as specified in Table 82.21-1 in a format prescribed by the department.

*Note:* Test results shall be submitted on the Cross Connection Control Device Performance Test form (SBD-9927), available on request from the department at the Safety and Buildings Division, P.O. Box 7302, Madison WI 53707-7302; Fax (608) 267-0592, S&B web address: <http://www.commerce.state.wi.us/SB/SB-Forms.html>.

b. As specified in Table 82.21-1, the results of the cross connection device performance test shall be submitted to the department and purveyor within 60 days of completion of the test.

5. The results of performance tests for the devices or assemblies listed in Table 82.21-1 shall be made available upon request to the department, its agent, or the local governmental unit.

(c) The maintenance and performance testing requirements of this subsection shall also apply to those cross connection control devices or assemblies installed prior to the effective date of this subsection.



**Table 82.21-1**  
**TESTING AND SUBMITTING REQUIREMENTS FOR CROSS CONNECTION**  
**CONTROL DEVICES OR ASSEMBLIES**

Industry Common Name of Assembly	ASSE Standard Name and Number	CAN/CSA Standard Name and Number	ASSE Test Standard	Test Results Submitted To Department and Purveyor
			5010-1015-1,	No <sup>a</sup>
DCV	Double check backflow prevention assembly ASSE 1015	Backflow preventer, double check valve type (DCVA) CAN/ CSA-B64.5-94	5010-1015-2, 5010-1015-3, 5010-1015-4	
			5010-1048-1,	No <sup>a</sup>
DCV detector	Double check detector assembly backflow preventer ASSE 1048	— —	5010-1048-2, 5010-1048-3, 5010-1048-4	
PVB	Pressure vacuum breaker assembly ASSE 1020	Vacuum breaker, pressure type (PVB) CAN/CSA-B64.1.2-94	5010-1020-1	Yes
RP	Reduced pressure principle backflow preventer ASSE 1013	Backflow preventer, reduced pressure principle type (RP) CAN/CSA-B64.4-94	5010-1013-1	Yes
RP Detector	Reduced pressure detector backflow preventer ASSE 1047	— —	5010-1047-1	Yes
SVB	Backsiphonage backflow vacuum breaker ASSE 1056	— —	Per department approved guidelines	Yes

<sup>a</sup> The results of the performance test shall be maintained at the site where the device is installed.

**History:** Cr. Register, February, 1985, No. 350, eff. 3-1-85; r. and recr. (1) (d) 5., am. (1) (d) 7. intro., Register, May, 1988, No. 389, eff. 6-1-88; correction in (1) (c) made under s. 13.93 (2m) (b) 7., Stats., Register, May, 1988, No. 389; renum. (1) (a) and (2) (b) to (i) to be (1) (a) 1. and (2) (a) to (h), r. (2) (a), cr. (1) (a) 2. and (3), r. and recr. (1) (d) 1. (intro.), am. (1) (d) 2. (intro.), Register, February, 1994, No. 458, eff. 3-1-94; am. (3) (b) 3., Register, October, 1996, No. 490, eff. 11-1-96; am. (3), Register, February, 1997, No. 494, eff. 3-1-97; r. and recr. (2) (a) and (3), cr. Table 82.21-1, Register, December, 2000, No. 540, eff. 1-1-01; CR 02-002: r. and recr. (1) (b) 4. b. and (2) (d), am. (1) (d) 8. b. Register April 2003 No. 568, eff. 5-1-03.

### Subchapter III — Drain and Vent Systems

**Comm 82.30 Sanitary drain systems. (1) SCOPE.** The provisions of this section set forth the requirements for the design and installation of sanitary drain systems, including building drains and building sewers.

**Note:** The provisions for storm and clear water drain systems are specified in s. Comm 82.36.

**(2) MATERIALS.** All sanitary drain systems shall be constructed of approved materials in accordance with ch. Comm 84.

**(3) LOAD ON DRAIN PIPING. (a) Intermittent flow fixtures.** The load factor on drain piping shall be computed in terms of drainage fixture unit values specified in Table 82.30-1 for the corresponding fixture listed. Drainage fixture unit values for intermittent flow fixtures not listed in Table 82.30-1 shall be computed on the basis of one fixture unit equalling 7.5 gallons per minute of flow.

**(b) Continuous flow devices.** Drainage fixture unit values for continuous or semicontinuous flow devices such as pumps, ejectors, air conditioning equipment or similar devices shall be computed on the basis of one fixture unit for each 2 gallons per minute of flow rate of discharge into the drain system.

**TABLE 82.30-1  
DRAINAGE FIXTURE UNIT VALUES  
BY FIXTURE TYPE**

Type of Fixture	Drainage Fixture Unit Value (dfu)	Trap Size Minimum Diameter (inches)
Automatic clothes washers:		
Commercial, individual	4	2
Commercial, large capacity	a	a
Self Service Laundry	3	1 1/2
Residential	3	1 1/2
Autopsy Table	h	h
Bathroom Group, includes: water closet, lavatory, bathtub or shower	6	
Bathtubs, all types <sup>b</sup>	2	1 1/2
Bedpan Washer	6	2
Beer Tap	1/2	1 1/4
Bidet	2	1 1/2
Bottle Cooler	1/2	1 1/4
Campsite Receptor	6	4
Coffee Maker	1/2	1 1/4
Cuspidor, fountain or dental	1	1 1/4
Dipper Well	1	1 1/4
Dishwasher, commercial type	c	c
Dishwasher, residential type	2	1 1/2
Drinking Fountain	1/2	1 1/4
Exhaust Hood Washer	4	2
Floor Drain:		
2 inch	2	2
3 inch	3	3
4 inch	4	4
Larger than 4 inch	4	d
Glass Filler	1/2	1 1/4
Glass Washer	2	1 1/2
Health Care Fixtures:		
Clinic sink	6	NA
Exam/treatment sink	1	1 1/4
Sitz bath	2	1 1/2
Ice Chest	1/2	1 1/2
Laundry Tray, 1 or 2 compartment	2	1 1/2
Lavatory	1	1 1/4
Mobile Home	11	NA
Refrigerated Food Display Case	1	1
Shower Stall:		
Residential	2	2
Public, individual	2	2
Public, group	2 per shower head	2
Sinks: <sup>i</sup>		
Breakroom (single compartment)	1	1 1/2
Cup	1/2	1 1/4
Factory, wash, per set of faucets	1	1 1/2
Fountain wash up	1	1 1/2
Fountain or Bar, 4 compartments or less	3	1 1/2
Food Waste Grinder, commercial 2 HP or less	2	f
Food Waste Grinder, commercial 3 HP or more	3	f

**TABLE 82.30-1 (Continued)  
DRAINAGE FIXTURE UNIT VALUES  
BY FIXTURE TYPE**

Type of Fixture	Drainage Fixture Unit Value (dfu)	Trap Size Minimum Diameter (inches)
Laboratory	2	1 1/2
Laboratory, school	2	1 1/2
Classroom	1	1 1/4
Pack or plaster	3	2
Residential, with or without food waste grinder	2	1 1/2
Restaurant, Scullery, pots and pans — 4 compartments or less	3	f
Food, rinsing, cleaning or thawing	3	2
Service Sink, Flushing Rim	6	3
Service Sink, 2 inch diameter, wall outlet	2	2
Service Sink, 3 inch diameter, wall outlet	3	3
Service Sink, 2 inch diameter, floor outlet	2	2
Service Sink, 3 inch diameter, floor outlet	3	3
Shampoo Sink, barber or beauty parlor	2	1 1/2
Surgeons, wash up	3	1 1/2
Wash Fountain, circular and semi-circular	2	1 1/2
Receptors of Indirect Wastes, gravity flow discharge:		
1 1/4 inch receptor outlet diameter	1	1 1/4
1 1/2 inch receptor outlet diameter	2	1 1/2
2 inch receptor outlet diameter	3	2
3 inch receptor outlet diameter	4	3
4 inch receptor outlet diameter	6	4
Larger than 4 inch receptor outlet diameter	8	f
Soda Dispenser	1/2	1 1/4
Sterilizers:		
Bedpan	4	2
Garbage can washer	3	3
Instrument or water	1	
Urinal	2	g
Water Closet, nonpublic	4	g
Water Closet, public	6	g

NA = not applicable  
<sup>a</sup> Based on discharge rate of the fixture.  
<sup>b</sup> Includes foot, sitz and infant baths and regular bathtubs with or without showers or whirlpool circulation piping.  
<sup>c</sup> Based on discharge rates and number of outlets; a 4" diameter trap and drain pipe minimum recommended.  
<sup>d</sup> Trap size corresponds to the size of the floor drain.  
<sup>f</sup> Trap size corresponds to the size of the drain outlet.  
<sup>g</sup> Trap size specified in referenced standards of s. Comm 84.20.  
<sup>h</sup> Trap size corresponds to the size of the drain outlet. Use the dfu value of the receptor serving the autopsy table.  
<sup>i</sup> Sinks not specified in this table shall be assigned 1 dfu for 1 1/4" tailpiece, 2 dfu for 1 1/2" tailpiece and 3 dfu for 2" tailpiece.

**(4) SIZE OF DRAIN PIPING.** (a) *Maximum loading.* 1. The total drainage load in any portion of drain piping shall not exceed the limits specified in Tables 82.30-2 and 82.30-3.  
 2. The drainage fixture unit values assigned to a receptor which is to receive only the indirect waste discharge from a relief valve on a domestic water heater may be disregarded when determining the minimum size of the building drain and building sewer. Any drain piping between the receptor and the building drain shall be sized by including the assigned fixture unit values for the type of receptor.  
 Note: See s. Comm 82.31 (17) for sizing requirements of combination drain and vent systems.  
 Note: See Appendix for further explanatory material.

(b) *Minimum size of underground drain piping.* Any pipe of the drain system installed underground, other than the building sewer, shall not be less than 2" in diameter. Any portion of underground drain piping which is 2" in diameter shall not exceed a length of 20 feet.

Table 82.30-2

**HORIZONTAL AND VERTICAL DRAIN PIPING**

Pipe Diameter (inches)	Maximum Number of Drainage Fixture Units Which May Drain Through Any Portion of Horizontal and Vertical Drain Piping			
	Horizontal Drain Piping <sup>a</sup>	Vertical Drain Piping of 3 Branch Intervals or Less <sup>b</sup>	Vertical Piping in Drain Stacks of More Than 3 Branch Intervals <sup>b</sup>	
			Total Discharge from Side Connections into One Branch Interval	Total Discharge through Any Portion
1 1/4	1	2	1	2
1 1/2	3	4	2	8
2	6	10	6	24
3	20	48	20	72
4	160	240	90	500
5	360	540	200	1,100
6	620	960	350	1,900
8	1,400	2,200	600	3,600
10	2,500	3,800	1,000	5,600
12	3,900	6,000	1,500	8,400

<sup>a</sup> Does not include building drains and building sewers.

<sup>b</sup> Drain stacks may be reduced in size as the drainage load decreases to a minimum diameter of one half of the diameter required at the base of the stack, but not smaller than that required for a stack vent under s. Comm 82.31 (14) (a).

Table 82.30-3

**BUILDING DRAINS, BUILDING SUBDRAINS, BUILDING SEWERS AND PRIVATE INTERCEPTOR MAIN SEWERS<sup>a</sup>**

Pipe Diameter (inches)	Maximum Number of Drainage Fixture Units Which May Drain Through Any Portion of a Building Drain, Building Subdrain, Building Sewer or Private Interceptor Main Sewer			
	Pitch (inch per foot)			
	1/16	1/8	1/4	1/2
2	NP <sup>b</sup>	NP	6	9
3	NP	36	42	50
4	NP	180	216	250
5	NP	390	480	575
6	NP	700	840	1,000
8	1,400	1,600	1,920	2,300
10	2,500	2,900	3,500	4,200
12	3,900	4,600	5,600	6,700
15	7,000	8,300	10,000	12,000

<sup>a</sup> Private interceptor main sewers 6 inches or less in diameter, see s. NR 110.13 for private interceptor main sewers 8 inches or larger in diameter.

<sup>b</sup> NP means Not Permitted.

Note: For further explanatory material see Appendix A-82.30 (4).

(c) *Minimum size of building sewers.* 1. Gravity flow sewers. The minimum size of a gravity flow sanitary building sewer shall be 4" in diameter. A municipality or sanitary district by ordinance may require that portion of the building sewer between the lot line and the public sewer to be larger than 4" in diameter.

2. Pressurized sewers. a. Sewers pressurized through the use of sewage ejectors, sewage pumps or sewage grinder pumps shall be sized to maintain a minimum flow velocity of 2 feet per second and shall be in accordance with the ejector or pump manufacturer's recommendations.

b. Pressurized building sewers shall be sized not less than 2" in diameter for sewage ejectors and sewage pumps, and 1 1/4" in diameter for all sewage grinder pumps.

(d) *Minimum size of private interceptor main sewers.* 1. Except as provided in subd. 3., the minimum size of a gravity flow private interceptor main sewer shall be 4" in diameter.

2. Except as provided in subd. 3., the minimum size of pressurized private interceptor main sewer shall be such so as to maintain a minimum flow velocity of 2 feet per second.

3. A municipality or a sanitary district may by ordinance, require the minimum size of a private interceptor main sewer to be larger than 4" in diameter.

4. Private interceptor main sewers 6" or less in diameter may not exceed the drainage fixture limits in Table 82.30-3.

5. Private interceptor main sewers 8" or larger in diameter shall conform with the design criteria specified in s. NR 110.13.

Note: See Appendix A-82.30 (4) (d) for further explanatory material.

(e) *Future fixtures.* Where provisions are made for the future installation of fixtures, the drainage fixture unit values of such fixtures shall be considered in determining the required sizes of drain and vent pipes. Construction to provide for future installations shall be terminated with a plugged fitting or fittings.

(5) **PITCH OF HORIZONTAL DRAIN PIPING.** All horizontal drain piping 4" or larger in diameter shall be installed at a pitch which produces a computed velocity of at least 2 feet per second when flowing half full.

(a) *Horizontal branch drains.* 1. The minimum pitch of horizontal branch drains 2" or less in diameter shall be 1/4" per foot.

2. The minimum pitch of horizontal branch drains larger than 2" in diameter shall be 1/8" per foot.

(b) *Building drains and building sewers.* 1. The minimum pitch of building drains shall be in accordance with Table 82.30-3.

2. a. The minimum pitch of building sewers 10" or less in diameter shall be in accordance with Table 82.30-3.

b. The minimum pitch of building sewers 12" or larger in diameter shall conform with the minimum pitch specified for municipal sewers in s. NR 110.13.

Note: See also s. Comm 82.30 (4) (d) 5. for further explanatory material.

(c) *Private interceptor main sewers.* 1. The minimum pitch of private interceptor main sewers 6" or less in diameter shall be in accordance with Table 82.30-3.

2. The minimum pitch of private interceptor main sewers 8" or larger in diameter shall conform with the minimum pitch specified for municipal sewers in s. NR 110.13.

Note: See Appendix A-82.30 (4) (d) for further explanatory material.

(6) **OFFSETS IN VERTICAL DRAINS.** Offsets in vertical drain piping shall be in accordance with this subsection.

(a) *Offsets of 45° or less.* 1. An offset in a vertical drain, with a change in direction of 45° or less from the vertical, shall be sized as a vertical drain piping in accordance with sub. (4).

2. Where a horizontal branch connects to a stack within 2 feet above or below an offset with a change of direction of 30 to 45° from the vertical and the offset is located below 2 or more branch intervals, a relief vent shall be installed in accordance with s. Comm 82.31 (5).

(b) *Offsets of more than 45°.* A drain stack with an offset of more than 45° from the vertical shall be installed in accordance with subds. 1. to 5.

1. That portion of the stack above the highest offset fitting shall be sized as for vertical drain piping in accordance with sub. (4).

2. That portion of the offset between and including the offset fittings shall be sized as horizontal drain piping in accordance with sub. (4).

3. That portion of stack below the offset shall be not less than the size of the offset and not less than the size required for vertical drain piping in accordance with sub. (4).

4. No horizontal branch drain may connect to the stack offset downstream from the offset's highest fitting within the distance equal to 10 pipe diameters of the offset.

5. Where an offset is located below 2 or more branch intervals, a relief vent and a yoke vent shall be installed in accordance with s. Comm 82.31 (5).

Note: See Appendix for further explanatory material.

(7) **HORIZONTAL BRANCH DRAIN CONNECTION AT BASE OF A STACK.** (a) A horizontal branch drain may not connect downstream from the base fitting of a drain stack 2" or larger in diameter within the distance equal to 10 pipe diameters of the drain to which the horizontal branch drain connects.

(b) A building drain branch or building subdrain branch may not connect to a building drain or building subdrain downstream from the base fitting of a drain stack 2" or larger in diameter within the distance equal to 20 pipe diameters of the building drain or building subdrain.

Note: See Appendix for further explanatory material.

(8) **PIPING CHANGES IN DIRECTION.** Changes in the direction of drain piping shall be accomplished in accordance with the requirements of this subsection.

(a) *Fittings.* All changes in direction of flow in drain piping shall be made by the appropriate use of 45 degree wyes, long or short sweep quarter bends, sixth, eighth, or sixteenth bends, or by a combination of these or other equivalent fittings. Except as provided in subds. 1. to 3., fittings which change the direction of flow for drain piping 8" or less in diameter shall conform to the minimum radii specified in Table 82.30-4.

Note: See Appendix for further explanatory material.

1. The minimum radius for the first 90° fitting downstream from a trap serving a lavatory or sink shall be 1-3/4" for drain piping 1-1/2" in diameter. The fitting shall be a tee or quarter bend.

2. The minimum radius for the first 90° bend or elbow downstream from a water closet shall be 2-1/2" for drain piping 3" in diameter.

3. The minimum radius for the first 90° bend or elbow downstream from a water closet shall be 3" for drain piping 4" in diameter.

**Table 82.30-4  
MINIMUM RADII OF FITTINGS (in inches)**

Diameter of pipe (inches)	Changes in Direction of Flow	
	Horizontal to Vertical	Vertical to Horizontal and Horizontal to Horizontal
1-1/4	1-1/8	2-1/4
1-1/2	1-3/8	2-3/4
2	1-7/8	3-1/4
3	2-7/8	4-1/16
4	3-3/4	4-7/8
5	4-1/2	6-1/2
6	5	7
8	6	8

(b) *Blowout type fixtures.* Where blowout type fixtures are installed back to back, appropriate fittings shall be installed to prevent the passage of wastes from one fixture to the other.

(9) **DRAIN FITTINGS AND CONNECTIONS.** Drain fittings, connections, devices and methods of installation shall not obstruct or retard the flow of water, wastes, sewage or air in the drain system or venting system in an amount greater than the normal frictional resistance to flow, unless as otherwise permitted in this chapter or unless approved by the department.

(a) *Closest bend.* The reduction of a 4 x 3 inch closet bend or collar fitting from 4" to 3" shall not be considered an obstruction.

(b) *Side inlet tees or bends.* The side inlet of a low pattern or high pattern tee or bend shall not be used as a vent connection when the side inlet is placed in a horizontal position or when any arrangement of piping or fittings produces a similar effect.

Note: See Appendix for further explanatory material.

(c) *Prohibited fittings and connections.* The types of fittings and connections specified in subds. 1. to 4. shall not be used for drain piping:

1. A heel inlet bend when the heel inlet is in the horizontal position;

2. A fitting or connection which has an enlargement chamber or recess with a ledge or shoulder, or reduction in pipe area in the direction of flow;

3. A fitting which has running threads; and

4. A connection by means of drilling and tapping of a drain or vent pipe, unless as otherwise approved by the department.

(d) *Saddles.* If a pipe saddle is used to connect drain piping together, the saddle shall be installed in accordance with s. Comm 84.30 (5) (d).

(10) **SUMPS, EJECTORS AND PUMPS.** (a) *Sumps.* 1. General. All sanitary building subdrains shall discharge into an approved,

vented sump with an airtight cover. The sump shall be so located as to receive the sewage by gravity flow, and shall be located at least 25 feet from any water well.

2. Capacity. Except as provided in pars. (c) and (d), the minimum capacity of the sump shall be determined in accordance with the provisions of subd. 2. a. to e.

a. The water supply fixture unit method shall be used to determine peak input flow in gallons per minute; only the fixtures that drain to the sump shall be included.

**Note:** When converting water fixture units to gallons per minute it is permissible to calculate the load as a supply system with predominantly flush tanks.

b. The capacity of the sump shall be such that the pump when actuated by the lowest "pump on" switch runs at least 20 seconds.

c. Between the highest "pump on" switch level and the sump inlet, the sump shall hold the amount of input that exceeds the discharge of the pumping equipment in a 5 minute peak input period, but in no case shall the vertical distance between the switch and the inlet be less than 3".

d. The low water level shall be maintained in accordance with the pump manufacturer's requirements, but shall not be less than 4" above the sump bottom.

e. Minimum sump diameter. Sumps containing one pump shall have an inside diameter of at least 24". Sumps containing 2 pumps shall have an inside diameter of at least 30".

**Note:** See Appendix for further explanatory material.

3. Vents. All sumps and all drains leading to a sump shall be vented in accordance with s. Comm 82.31.

4. Materials. All sumps shall be constructed in a watertight manner of approved materials in accordance with ch. Comm 84.

5. Removable covers. Penetrations through the top of removable sump covers shall be limited to those for the electrical supply, the vent piping and the discharge piping for the pump or pumps.

(b) *Ejectors and pumps.* 1. Where required. The liquid from all sanitary building sumps shall be lifted and discharged into the building sanitary drain system by automatic ejectors, pumps or any other equally efficient method approved by the department.

2. Duplex equipment. a. Duplex ejector or pumping equipment shall be installed in a public building where 3 or more water closets or more than 20 drainage fixture units discharge into a sump.

b. Duplex ejector or pumping equipment shall be installed where the sanitary wastes of 2 or more one- or 2-family dwellings discharge into a sump.

c. Where duplex ejector or pumping equipment is installed, appropriate devices shall be installed to automatically alternate operation of the pumps or ejectors and to operate both pumps or ejectors when one unit cannot handle the load.

d. Where duplex pumping equipment is installed, an audible or visual alarm system with a manual control reset shall be installed to indicate pump failure.

3. Size. The size and design of an ejector or pump shall be determined by the capacity of the sump to be served, the discharge head and discharge frequency. All ejectors and pumps shall provide a minimum flow velocity of 2 feet per second in the forced discharge piping.

**Note:** See Appendix A-82.30 (10) (b) 3. for velocity in relation to flow rate by various pipe sizes.

**Note:** Ejectors or pumps discharging to septic tanks may disturb the settling properties of the tank environment; contact the Safety and Buildings Division for more information.

a. All sewage grinder pumps shall have a minimum 1 1/4" diameter discharge opening and discharge piping.

b. All nongrinder-type sewage pumps serving water closets shall be capable of passing a 2" diameter solid ball and shall have a minimum 2" diameter discharge opening and discharge piping. All other pumps handling sanitary wastes shall be rated by the manufacturer as an effluent pump, shall be capable of passing a 1/2" diameter solid ball and shall have a minimum 1 1/4" diameter discharge opening and discharge piping.

4. Discharge connections. a. The discharge pipe from the ejector or pump shall be connected to the gravity drain by means of a wye pattern fitting. Where the fitting connects to a horizontal drain, the bottom of the wye branch of the fitting shall be located above the horizontal center line.

b. With the exception of exterior sumps, a full flow check valve shall be installed in the discharge piping from each ejector or pump.

c. Where duplicate ejector or pumping equipment is installed, each discharge pipe from an ejector or pump shall be provided with a gate or ball type valve installed downstream of each full flow check valve.

5. Discharge pipe air relief. Air relief valves shall be provided at all high points in the discharge piping of an ejector or pump where the piping arrangement creates an air trap.

6. Prohibited connections. No fixtures may be connected to the discharge pipe between the ejector or pump and the point where it enters the gravity drain.

7. Maintenance. All ejectors, pumps and like appliances shall receive care as needed to keep them in a satisfactory operating condition.

(c) *Prefabricated pumps and sump systems.* The minimum capacity of a prefabricated pump and sump system shall be determined in accordance with all of the following:

1. The water supply fixture unit, wsfu, method shall be used to determine peak input flow in gallons per minute. The peak input shall include all the fixtures that drain to the sump.

2. Unless storage is provided as specified in par. (a) 2., the capacity of the prefabricated pump and sump system shall accommodate the peak input flow.

3. The low water level shall be maintained in accordance with the pump manufacturer's requirements.

(d) *Exterior sumps.* The minimum capacity of exterior sumps shall be determined in accordance with all of the following:

1. Peak input flow in gallons per minute shall be determined in accordance with either of the following:

a. The water supply fixture unit, wsfu, method of all the fixtures that drain to the sump.

b. The provisions as specified in s. Comm 83.43 (2) through (6).

2. In lieu of providing the duplex pumping equipment as specified in par. (b) 2., a one-day holding capacity may be provided above a high level alarm when installed on a simplex system.

(11) BUILDING DRAINS AND BUILDING SEWERS. (a) *Limitations.* No building sewer may pass through or under a building to serve another building, unless:

1. The building sewer serves farm buildings or farm houses, or both, which are all located on one property; or

2. The building sewer or private interceptor main sewer serves buildings located on the same property and a document, which indicates the piping and distribution arrangement for the property and buildings, shall be recorded with the register of deeds no later than 90 days after installation.

(b) *Building drains.* 1. Elevation. a. All building drains shall be installed below the lowest floor levels on which fixtures may be installed if the public sewer, POWTs or private interceptor main sewer elevation permits.

b. Where any portion of an above-ground building drain discharges to a vertical pipe, the building drain shall connect to the building sewer at an elevation at least 30" above the basement floor.

**Note:** See Appendix for further explanatory material.

2. Backwater protection. A building drain subject to backflow or backwater shall be protected with a backwater valve or with a sump with pumping equipment in accordance with sub. (10).

a. Backwater valves, when fully open, shall have a capacity not less than that of the pipes in which installed.

b. Backwater valves shall be so located as to be readily accessible for cleaning.

3. Floor drain required. a. Where a plumbing fixture or appliance is located on a floor which is entirely below grade, a floor drain shall be installed to serve that floor.

b. In any room containing the recessed or concealed portions of sterilizers located in health care or related facilities, at least one floor drain connecting to the drainage system shall be installed in a manner to adequately drain the entire floor area.

(c) Building sewers. 1. Minimum depth. a. The top of a building sewer shall be located at a depth of not less than 42" below finished grade, except as provided in subd. 1. b. or subd. 2.

b. The top of a building sewer which discharges to a septic tank, holding tank or grease interceptor shall be located at a depth of not less than 18" below finished grade.

2. Protection from frost. a. Except as provided in subd. 2. c. to e., a building sewer or private interceptor main sewer shall be protected from frost in accordance with subd. 3. in areas where the top of the building sewer or private interceptor main sewer is located less than 60" below a surface area from which snow will be cleared.

b. Except as provided in subd. 2. c. to e., a building sewer or private interceptor main sewer shall be protected from frost in accordance with subd. 3. in areas where the top of the building sewer or private interceptor main sewer is located less than 42" below a surface area which snow will not be cleared.

c. Where a building sewer or private interceptor main sewer discharges to a holding tank, POWTs treatment tank or grease interceptor, the portion of a building sewer or private interceptor main sewer which is within 30 feet from the connecting building drain and which is under a surface area from which snow will not be cleared shall not be required to be protected from frost.

d. Frost protection for a building sewer shall not be required where the predicted depth of frost as determined from Figure 82.30-1 and Table 82.30-6 does not extend below the top of the building sewer.

e. Where a building sewer or private interceptor main sewer is installed to serve summer use public facilities, frost protection requirements shall not apply.

Note: This exemption applies to frost sleeves as provided in s. Comm 82.35 (5) (a) 2.

3. Insulation for building sewers. Where required by subd. 2. a. or b., building sewer or private interceptor main sewer insulation for frost protection shall be provided in accordance with one of the methods specified in subd. 3. a. to d.

a. Extruded polystyrene foam insulation shall be installed at a depth of at least 18" below finished grade and at least 6" above the top of the sewer pipe. The minimum thickness and width of the foam insulation shall be determined from Figure 82.30-1 and Tables 82.30-5 to 82.30-7. If the insulation is to be installed more than 6" above the top of the sewer, the number of inches exceeding 6" shall be added to the width of insulation determined from Table 82.30-7.

Figure 82.30-1. Frost protection zones.

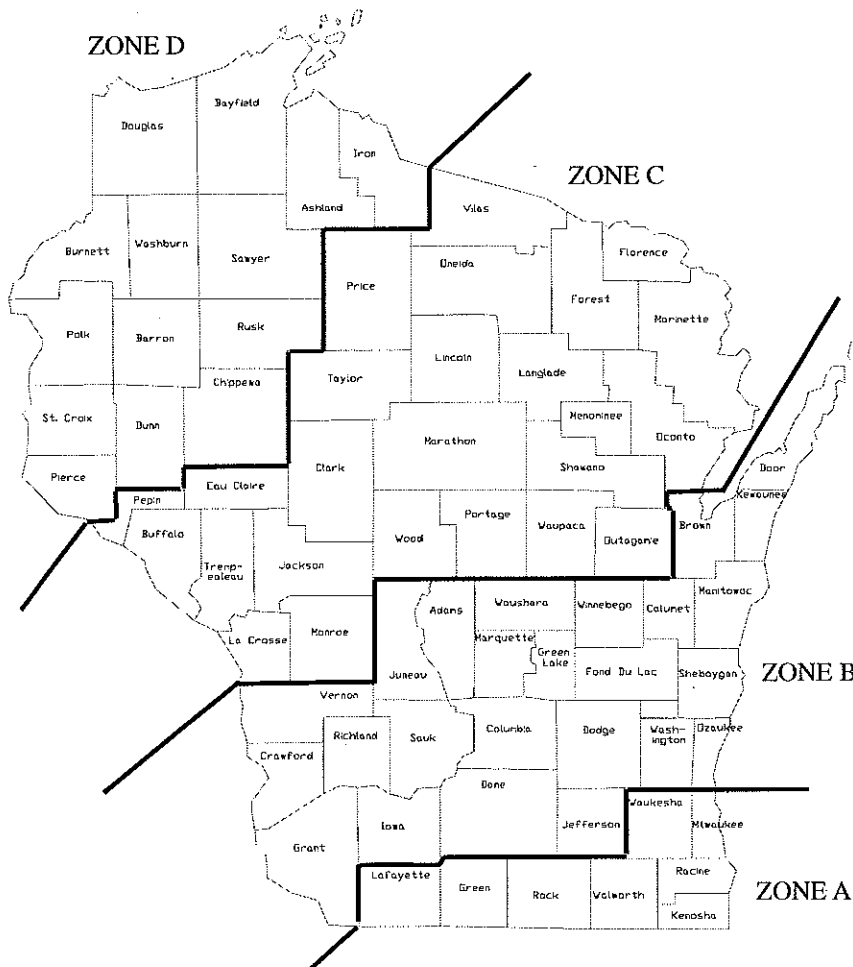

Table 82.30-5  
MINIMUM THICKNESS OF INSULATION

Frost Protection Zone	Extruded Polystyrene Foam (in inches)	Insulating Concrete (in inches)
A	1.0	6
B	1.5	9
C	2.0	12
D	2.5	15

Table 82.30-6  
PREDICTED DEPTH OF FROST IN VARIOUS TYPES OF BACKFILL SOIL (in feet)

Soil Type	Frost Protection Zone			
	A	B	C	D
Clay, Clay Loam	2.5	3.0	3.5	4.0
Silt Loam, Silty Clay Loam	3.5	4.0	4.5	5.5
Sandy Clay Loam	4.0	4.5	5.5	6.0
Sandy Loam, Loamy Sand	4.5	5.0	6.0	6.5
Sand	5.0	5.5	6.5	7.5
Gravelly Sand	6.0	7.5	9.0	10.0

b. Extruded polystyrene foam insulation shall be installed using a box method. The 3-sided box shall be formed with 3 lengths of polystyrene foam insulation where the top of the box extends horizontally to the farthest edge of both vertical sides. The insulation shall be installed at or below a depth of at least 12" below finished grade and 6" inches above the top and 6" from each side of the building sewer or private interceptor main sewer. The minimum thickness of the foam insulation shall be determined from Figure 82.30-1 and Table 82.30-5.

Note: See Appendix A-82.30 (11) (c) for further explanatory material.

c. Lightweight insulating concrete shall be installed to the depth of the spring line of the sewer and shall extend laterally at least 6" on both sides of the sewer. The minimum thickness of the insulating concrete shall be determined from Figure 82.30-1 and Table 82.30-5. The thickness shall be measured from the top of the sewer. The top of the insulation shall be installed at least 12" below finished grade.

d. Alternative methods of frost protection shall be approved by the department.

(d) *Location limitations.* Building drains, building sewers or private interceptor main sewers shall be separated from water wells by the applicable separation distances contained in chs. NR 811 and 812 or as otherwise approved by the department of natural resources.

Note: See s. Comm 82.40 for provisions regarding the separation of water supply piping, building sewers and private interceptor main sewers.

Note: See Appendix A-82.30 (11) (d) for further explanatory material. Section NR 812.08 may require additional setbacks.

(e) *Installation of building drains and building sewers.* 1. Trenching. All excavations for building drains and building sewers shall be open trench work, unless otherwise permitted by local ordinance or accepted by the local inspector.

2. Stable bottom. Where the bottom of the trench can be maintained in a stable condition and free of water during the time of installation the building drain and the building sewer shall be bedded and initially backfilled as specified in this subdivision. Grade, as used in this subdivision, shall mean the elevation of the bottom of the building drain or the building sewer.

a. Except where sand is encountered, the trench bottom throughout its length shall be excavated to a depth at least 3" below the grade elevation and shall be brought back to grade with sand, pea gravel, or a graded stone bedding. The bedding material shall be of a size that all the material shall pass a  $3/4$ " sieve. When sand is used as a bedding material it shall not contain excessive moisture and the bedding in the entire trench width shall be hand or mechanically tamped to compact it to a minimum of 90% Stan-

dard Proctor Density. All bedding shall be shaped to accommodate pipe bells or couplings. Initial backfill on the sides of the pipe and to a depth of 12" over the pipe shall be sand, gravel, crushed stone or excavated material which is neither corrosive nor organic in nature. A concrete floor may be placed over a building drain having less than 12" of initial backfill. Initial backfill material shall be of a size that all the material shall pass a one inch sieve. Initial backfill material shall be placed in increments not exceeding 6" in depth and shall be well tamped for the full width of the trench and for the full length of the sewer.

b. Where the trench bottom does not contain stone larger than one inch in size or where bedrock is not encountered, the trench may be excavated to grade. Where stone larger than one inch in size or when bedrock is encountered, the trench shall be excavated to a depth at least 3" below the grade elevation and shall be brought back to grade with a bedding of sand, gravel, or crushed stone which shall be of a size that all the material shall pass a  $3/4$ " sieve. The bedding material shall be shaped to accommodate the pipe bells or couplings. Initial backfill on the sides of the pipe and to a depth of 3" over the pipe for that part of the pipe laid on private property shall be well tamped sand, gravel, crushed stone or excavated material which is neither corrosive nor organic in nature. A concrete floor may be placed over a building drain having less than 3" of initial backfill. Initial backfill material shall be of a size that all the material shall pass a one inch sieve. For that portion of the sewer in the street right of way, the initial backfill material to a depth of 12" over the pipe shall be sand, gravel or crushed stone which shall be of a size that all the material shall pass a one inch sieve. Initial backfill material shall be placed in increments not exceeding 6" and shall be well tamped.

3. Unstable bottom. Where a mucky or unstable bottom is encountered in the trench, the required dry and stable foundation conditions shall be provided by sheathing driven and left in place to a depth of 48" below the trench bottom or to solid foundation at a lesser depth, the removal of wet and yielding material to a depth of 24" or to solid material, and replacement of the unstable material with limestone screenings, pea gravel or equivalent material for the bedding under the pipe. The trench bedding shall be shaped to accommodate pipe bells or couplings. In lieu of the foregoing, the required dry and stable foundation conditions may be provided by installation of a longitudinally reinforced concrete cradle the width of the trench and at least 3" thick or by installation of a longitudinally reinforced concrete slab the width of the trench at least 3" thick and bedding material as provided for in subd. 2. Initial backfill material and its placement shall conform to that

specified in subd. 2. All sheathing shall be cut off at a depth of 3 feet or more below the ground surface to prevent heaving due to frost action.

4. Backfill completion. Care shall be exercised in placing the

balance of the backfill to prevent breakage of the pipe. Large boulders or rock, concrete slabs, or frozen masses shall not be used in the backfill. At least 36" of backfill cover shall be provided over the top of the pipe before the pipe trench is wheel-loaded.

Table 82.30-7

MINIMUM WIDTH OF EXTRUDED POLYSTYRENE FOAM INSULATION (in feet)

Predicted Depth of Frost (feet)	Depth of Sewer (in feet)					
	2.0	2.5	3.0	3.5	4.0	4.5
2.5	2	NR				
3.0	3	2	NR			
3.5	4	3	2	NR		
4.0	5	4	3	2	NR	
4.5	6	5	4	3	2	NR
5.0	7	6	5	4	3	2
5.5	8	7	6	5	4	3
6.0	9	8	7	6	5	4
6.5	10	9	8	7	6	5
7.0	10	10	9	8	7	6
7.5	10	10	10	9	8	7
8.0	10	10	10	10	9	8
8.5	10	10	10	10	10	9
9.0	10	10	10	10	10	10
10.0	10	10	10	10	10	10

NR means Not Required.

5. Pipe openings protected. The ends of all pipes not immediately connected shall be closed so as to prevent the introduction of earth or drainage from an excavation.

(f) *Connection to public sewer.* The connections of building sewers to public sewers shall be in accordance with conditions of approval for the public sewer granted by the department of natural resources under s. 281.41, Stats.

1. Gravity public sewer. When a building sewer connection to the public sewer is not found within 3 feet of the point designated by the local governing body or its authorized representative, the connection shall be made in accordance with one of the provisions specified in subd. 1. a. to d.

a. A saddle fitting approved by the department and acceptable to the municipality or sanitary district shall be installed.

b. Where acceptable to the municipality or sanitary district a portion of the main sewer may be removed and a tee or wye fitting approved by the department may be inserted with compression joints in the public sewer acceptable to the municipality or the sanitary district. The insertion shall be made under the supervision of the authorized representative of the municipality or the sanitary district.

c. When the public sewer is concrete or clay, the end of the connecting sewer may be set upon or in an opening cut into the top half of the public sewer, but shall not protrude into the public sewer. The connection shall be secured by encasing the main sewer pipe and the connection in concrete at least 3" thick so as to assure permanency of the connection and adequate backing of the public sewer pipe.

d. In lieu of the use of a fitting and in the event that an opening cannot be located in the top half of the public sewer, a length of concrete or clay public sewer pipe may be removed and a section with a wye fitting shall be inserted in its place. The joints at the ends of the section shall be encased in concrete at least 3" thick. The connection or insertion shall be made under the supervision of the authorized representative of the municipality or the sanitary district.

2. Pressurized public sewer. Where a forced building sewer discharges to a pressurized public sewer, a full flow corporation

cock, full flow curb stop, check valve and dresser type coupling shall be installed. The curb stop, check valve and dresser type coupling shall be installed on the property as close as possible to the connection to the common forced main sewer. The check valve and dresser type coupling shall be accessible.

Note: See Appendix for further explanatory material.

(g) *Prohibited installations.* 1. Harmful discharge. No person may connect to a public sewer any building drain or building sewer through which is discharged any substance likely to cause undue corrosion, obstruction, nuisance, explosion or interference with sewage treatment processes.

2. Storm water and clear water connections. Except as provided in s. Comm 82.36 (3), storm drain piping and clear water drain piping may not discharge to a sanitary building drain which connects to a publicly-owned treatment works.

Note: See s. Comm 82.36 for provisions relative to storm sewers.

(12) PRIVATE INTERCEPTOR MAIN SEWERS. (a) The connection of a private interceptor main sewer to a public sewer shall be in accordance with the conditions of approval for the public sewer granted by the department of natural resources under s. 281.41, Stats.

(b) Private interceptor main sewers which discharge to a municipal treatment facility shall be designed in accordance with the appropriate water quality management plan.

(c) All private interceptor main sewers shall be tested in accordance with s. Comm 82.21.

(d) Private interceptor main sewers 6" or less in diameter shall be installed in accordance with the criteria for building sewers specified in sub. (11) (b) and (c) and (d) and (e).

(e) Private interceptor main sewers 8" or larger in diameter shall be:

1. Provided with frost protection in accordance with sub. (11) (c); and

2. Installed in accordance with the municipal sewer criteria specified in s. NR 110.13.

(f) No private interceptor main sewer may pass through or under a building to serve another building, unless one of the following conditions are met:



1. The private interceptor main sewer serves farm buildings, farm houses, or both which are located on one property.

2. The private interceptor main sewer serves buildings that are located on one property and a document, which indicates the piping and distribution arrangement for the property and buildings, shall be recorded with the register of deeds no later than 90 days after installation.

**(13) LOCATION OF DRAIN PIPING.** (a) Drain piping located below the ceilings of areas where food, ice or potable liquids are prepared, handled, stored or displayed shall be installed with the least number of joints and shall be installed in accordance with subs. 1. to 5.

1. All pipe openings through floors shall be provided with sleeves bonded to the floor construction and protruding not less than one inch above the top of the finish floor with the space between sleeve and the piping sealed.

2. Plumbing fixtures, except bathtubs and showers, shall be of the wall mounted type. Bathtubs shall have waste and overflow connections made above the floor and piped to a trap below the floor.

3. Floor and shower drains installed shall be equipped with integral seepage pans.

4. Cleanouts for piping shall be extended through the floor construction above.

5. Piping subject to operation at temperatures that will form condensation on the exterior of the pipe shall be thermally insulated.

(b) Where drain piping is located in ceilings of areas where food, ice or potable liquids are prepared, handled stored or displayed, the ceilings shall be of the removable type, or shall be provided with access panels in order to provide an access for inspection of the piping.

(c) Exposed drain piping shall not be located over a pool, surge tank or an open filter for a pool.

**History:** Cr. Register, February, 1985, No. 350, eff. 3-1-85; am. Table 82.30-1, (8) (a), (9) (c) (intro.) and 3., and (10) (b) 3. b., r. and recr. (4) (d) 2., Table 82.30-4, (10) (a) 2. b., (11) (intro.) and (f) 2., cr. (8) (a) 1. to 3. and (9) (d), r. (9) (c) 4., renum. (9) (c) 5. to be 4. and am., Register, May, 1988, No. 389, eff. 6-1-88; r. and recr. (4) (d), am. Table 82.30-3 and 82.30-7, r. (11) (intro.), renum. (11) (a) to (f) to be (b) to (g), cr. (11) (a) and (12) (f), Register, August, 1991, No. 428, eff. 9-1-91; am. Table 82.30-1, Register, April, 1992, No. 436, eff. 5-1-92; am. (7) (a) and (b), (11) (c) 1. a., (12) (e) 1. and Table 82.30-1, cr. (10) (a) 5., r. (11) (b) 1. b., renum. (11) (b) 1. c. to be (11) (b) 1. b., Register, February, 1994, No. 458, eff. 3-1-94; reprinted to restore dropped copy in (10) (b) 3. b., Register, July, 1994, No. 463; corrections in (11) (f) and (12) (g) made under s. 13.93 (2m) (b) 7., Stats., Register, April, 1998, No. 508; am. (11) (g) 2., Register, April, 2000, No. 532, eff. 7-1-00; CR 02-002: am. (4) (d) 5., (5) (b) 2. b., (c) 2., (10) (a) 2., (b) 4. b., (11) (b) 1. a., (c) 2. a. to c., 3. (intro.), (g) 2., (12) (f) (intro.) and 1., and Tables 82.30-1, 2, 3, 5 and 6, cr. (10) (b) 2. d., (c), (d), (11) (b) 3. b. and (c) 2. e., r. and recr. (11) (a) 2., (d), and (12) (f) 2., renum. (11) (b) 3., (c) 3. b. and c. to be (11) (b) 3. a., (c) 3. c. and d., Register April 2003 No. 568, eff. 5-1-03.

**Comm 82.31 Vents and venting systems. (1) SCOPE.** The provisions of this section set forth the requirements for the design and the installation of vents and venting systems.

**(2) MATERIALS.** All vents and venting systems shall be constructed of approved materials in accordance with ch. Comm 84.

**(3) GENERAL.** (a) *Vents.* Every trap and trapped plumbing fixture shall be provided with an individual vent, except as otherwise permitted in this chapter. Vents and venting systems shall be designed and installed so that the water seal of a trap shall be subject to a maximum pneumatic pressure differential equal to one inch of water column.

(b) *Main stack.* Each gravity-flow sanitary building sewer shall be served by at least one stack which extends from a building drain to a vent terminal or vent header. The stack shall be not less than 3" in diameter from the building drain to the vent terminal or vent header.

**(4) VENT STACKS AND STACK VENTS.** (a) *Where required.* Where individual vents, relief vents, or other branch vents are

required, a vent stack and a stack vent shall be installed to serve all drain stacks of 2 or more branch intervals.

(b) *Installation.* 1. The connection of the vent stack to a drain stack shall be at or below the lowest branch drain connection to the drain stack. The connection to the drain stack shall be by means of a wye pattern fitting installed in a vertical portion of the stack.

2. A vent stack and a stack vent shall:

a. Extend to a vent terminal in accordance with sub. (16);  
b. Connect to a vent stack which extends to a vent terminal;  
or

c. Connect to a stack vent at least 6" above the flood level rim of the highest fixture discharging into a drain stack.

3. Vent stacks and stack vents may connect into a common vent header and then shall extend to a vent terminal.

4. The connection of a vent stack with another vent may not be less than 38" above the next higher floor level where the plumbing fixtures are vented, but in no case lower than 2" above the elevation of the highest flood level rim of any fixture served by the vent.

**Note:** See Appendix for further explanatory material.

**(5) RELIEF AND YOKE VENTS FOR STACK OFFSETS.** (a) *Offsets of 30 to 45°.* Where a horizontal branch drain connects to a drain stack within 2 feet above or below a stack offset with a change of direction of 30 to 45° from the vertical and the offset is located below 2 or more branch intervals, a relief vent shall be installed in accordance with par. (c), except where an offset of more than 45° from the vertical is located in the drain stack within 12 feet above the offset of 30 to 45°.

(b) *Offsets of more than 45°.* Except as provided in subs. 1. and 2., where a drain stack has an offset of more than 45° from the vertical located below 2 or more branch intervals, a relief vent and a yoke vent shall be installed in accordance with par. (c).

1. Where an offset of more than 45° from the vertical is located in the drain stack within 12 feet above the lower stack offset, the installation of a yoke vent shall not be required.

2. Where the offset of more than 45° is located below the lowest branch drain connection, the installation of the relief vent shall not be required.

(c) *Installation.* 1. Relief vent. a. A relief vent serving a drain stack offset shall be installed as a vertical continuation of the portion of the stack below the offset or as a side connection to the portion of the stack below the offset. No drain connection may be installed between the offset and the side connection of the relief vent.

b. The connection of the relief vent to the drain stack shall be by means of a wye pattern fitting.

c. The connection of a relief vent with another vent may not be less than 38" above the next higher floor level where the plumbing fixtures are vented, but in no case lower than 2" above the elevation of the highest flood level rim of any fixture served by the vent.

2. Yoke vent. a. A yoke vent serving a drain stack offset shall connect to the drain stack at or below the lowest branch drain connection to the portion of the drain stack above the offset.

b. The connection of the yoke vent to the drain stack shall be by means of a wye pattern fitting.

c. The connection of the yoke vent to another vent may not be less than 38" above the next higher floor level where plumbing fixtures are installed that discharge into the drain stack.

**Note:** See Appendix for further explanatory material.

**(6) YOKE VENTS FOR STACKS OF MORE THAN 10 BRANCH INTERVALS.** Drain stacks of more than 10 branch intervals shall be provided with yoke vents.

(a) Yoke vents shall be installed not more than 10 branch intervals apart nor more than 10 branch intervals from the top or bottom of the drain stack.

(b) The connection of the yoke vent to the drain stack shall be by means of a wye pattern fitting.

(c) The connection of the yoke vent to another vent shall be not less than 38" above the next higher floor level where plumbing fixtures are installed that discharge into the drain stack.

**(7) RELIEF VENTS FOR BUILDING DRAINS.** A building drain with a change in elevation of 12 feet or more and at an angle of 45° or more from the horizontal shall be provided with a relief vent.

(a) The connection of the relief vent to the building drain shall be by means of a wye pattern fitting installed within 2 feet upstream of the top of the change in elevation.

(b) The connection of the relief vent to another vent shall be not less than 38" above the next higher floor level where plumbing fixtures are installed that discharge through the building drain.

Note: See Appendix for further explanatory material.

**(8) VENTS FOR SANITARY SUMPS.** (a) *Interior sanitary sumps.* Sanitary sumps shall be provided with a vent connecting either to the sump above the drain inlet or to the drain inlet within 12" of the sump.

(b) *Exterior sanitary sumps.* Sanitary sumps shall be provided with a vent that terminates in accordance with sub. (16) (h).

**(9) FIXTURE VENTS.** (a) *Developed length between vent and trap.* Each fixture trap shall be protected with a vent located in accordance with the provisions of subs. 1. and 2.

1. Each fixture trap which is not an integral part of the fixture shall be protected with a vent so located that the developed length of the fixture drain piping from the trap weir to the vent connection is within the limits set forth in Table 82.31-1.

2. Each fixture trap which is an integral part of the fixture shall be protected with a vent so located that the developed length of the fixture drain piping from fixture outlet to the vent connection is within the limits set forth in Table 82.31-1. For a floor outlet water closet or similar fixture, the point where the fixture drain piping turns horizontal shall be considered as the fixture outlet.

**Table 82.31-1  
MAXIMUM DEVELOPED LENGTH BETWEEN VENT AND TRAP (in feet)**

Diameter of Fixture Drain <sup>a</sup> (inches)	Vent Connecting to Horizontal Drain Piping			Vent Connecting to Vertical Drain Piping					
				by means of a Sanitary Tee Fitting			by means of a Wye Pattern Fitting <sup>b</sup>		
	Pitch of Fixture Drain (inch per foot)			Pitch of Fixture Drain (inch per foot)			Pitch of Fixture Drain (inch per foot)		
	1/8	1/4	1/2	1/8	1/4	1/2	1/8	1/4	1/2
1 1/4	NP <sup>c</sup>	5.0	2.5	NP	3.5	2.0	NP	1.5	1.0
1 1/2	NP	6.0	3.0	NP	5.0	3.0	NP	4.0	2.0
2	NP	8.0	4.0	NP	6.0	4.0	NP	4.5	4.0
3	24	12.0	6.0	10.0	8.0	6.0	8.0	6.0	6.0
4 <sup>d</sup>	32	16.0	8.0	12.0	10.0	8.0	10.0	8.0	8.0

<sup>a</sup> Diameters to be selected on the basis of the smallest drain pipe installed downstream from the trap serving a particular fixture.

<sup>b</sup> The wye pattern fitting refers to a tee-wye fitting, a combination wye and eighth bend fitting or a wye and eighth bend combination of fittings with no more than one inch between the wye fitting and eighth bend fitting.

<sup>c</sup> NP means Not Permitted.

<sup>d</sup> The maximum developed length for fixture drains larger than 4 inches in diameter shall be approved by the department.

(b) *Minimum distance.* A vent shall not connect to a fixture drain within the distance equal to 2 diameters of the drain piping from the weir of a trap.

Note: See Appendix for further explanatory material.

**(10) CIRCUIT VENTING.** In lieu of providing individual vents, a horizontal drain to which at least 2 but not more than 8 wall outlet fixtures or at least 2 but not more than 8 floor outlet fixtures, other than blowout type fixtures and wall-outlet carrier type water closets, are connected to the same horizontal branch drain, may be vented by a circuit vent in accordance with pars. (a) to (e).

(a) The circuit vent shall connect to the horizontal drain at a point between the 2 most upstream fixtures.

(b) 1. A circuit vented horizontal drain into which 4 or more fixtures discharge shall be provided with a relief vent. The relief vent shall connect to the circuit vented horizontal drain downstream of the most downstream fixture drain which is vented by the circuit vent and upstream of any other drain connections.

2. Two circuit vented horizontal drains serving a total of 8 fixtures, 4 on each branch, shall be provided with at least one relief vent, unless the horizontal drains connect to a drain stack with no other drain connections located above the circuit vented horizontal drains. One relief vent may serve both horizontal drains, if installed downstream of the point where the 2 horizontal drains are joined.

Note: See Appendix for further explanatory material.

(c) A horizontal drain served by a circuit vent shall not diminish in size from the connection to the drain stack to the circuit vent connection. Where a relief vent is installed, the horizontal drain

served by the circuit vent shall not diminish in size from the relief vent connection to the circuit vent connection.

(d) Fixture drains served by a circuit vent shall conform to the provisions of sub. (9). The connection of the fixture drain to the branch drain served by the circuit vent shall be considered as the vent connection.

(e) Additional wall outlet fixtures with a drainage fixture unit value of one or less which are served by individual vents or common vents may discharge into a horizontal drain served by a circuit vent.

**(11) COMMON VENTS.** In lieu of providing individual vents, fixtures may be common vented in accordance with pars. (a) and (b).

(a) *Vertical drains.* A common vent may serve a maximum of 2 fixtures where both fixture drains connect to a vertical drain at the same elevation. Where this connection is by means of a sanitary tee fitting with a side inlet, the centerline of the side inlet opening may not be below the centerline of the larger opening. The drain connection of a blowout type fixture or a kitchen sink served by a common vent may not be by means of a double sanitary tee fitting.

(b) *Horizontal branches.* The fixture drains from 2 wall-outlet fixtures, each with a drainage fixture unit value of one or less, or the fixture drains from 2 traps serving a kitchen sink with or without a dishwasher may connect to a horizontal branch without individual vents provided a common vent connects to the branch drain downstream of both fixture drains. Both fixture drains shall be of

the same diameter. The developed length of the drain from the vent to the farthest trap shall conform to sub. (9).

Note: See Appendix for further explanatory material.

**(12) RETURN VENTS.** Plumbing fixtures may be vented in accordance with pars. (a) to (d).

(a) Wall outlet fixtures may be vented by extending an individual vent, vertical wet vent or a common vent as high as possible under the fixture enclosure and returning the vent vertically downward and connecting the vent to the fixture drain or branch drain by means of a wye pattern fitting.

(b) Horizontal vent piping shall connect to the vertical section of the fixture vent and extend to a point where it can extend vertically to a vent terminal in accordance with sub. (16) or connect to another vent in accordance with sub. (15).

(c) Drainage fittings shall be used on all sections of the vent pipe below the floor level and a minimum slope of  $\frac{1}{4}$ " per foot to the drainage point shall be provided.

(d) Cleanouts shall be provided on the vent piping in accordance with s. Comm 82.35.

Note: See Appendix for further explanatory material.

**(13) WET VENTING.** In lieu of providing individual vents, fixtures may be wet vented in accordance with pars. (a) to (c).

(a) *Vertical wet vents.* 1. Where 2 wall outlet fixtures are located on the same floor level with their fixture drains connecting to the same vertical drain pipe at different elevations, the lower fixture drain may be wet vented in accordance with subd. 1. a. to e.

a. No other fixtures may discharge into the vertical drain pipe above or between the 2 wall outlet fixtures. Additional fixtures may discharge into the vertical drain pipe below the 2 wall outlet fixtures.

b. A branch vent shall connect to the vertical drain pipe immediately above the higher fixture drain connection.

c. The drain between the 2 fixtures shall be at least one pipe size larger than the upper fixture drain, but not smaller than 2" in diameter.

d. Both fixture drains shall conform to sub. (9). The connection of the lower fixture drain to the vertical drain shall be considered as the vent connection.

e. The higher fixture drain may not serve a water closet or urinal.

Note: See Appendix for further explanatory material.

(b) *Horizontal wet vents.* A drain from a lavatory or lavatories which are either provided with individual vents or a common vent may serve as the wet vent for not more than 2 bathtubs or showers and not more than 2 water closets in accordance with subds. 1. to 7. No other fixtures may discharge into or be served by the wet vent.

1. All of the fixtures shall be located in nonpublic bathroom groups.

2. The lavatories and bathtubs or showers shall have a common horizontal drain with the drain for the lavatories serving as a wet vent for the bathtubs or showers.

3. Where 2 bathtubs or showers are served by the same wet vent, their fixture drains shall connect independently to the common horizontal drain downstream of the vertical drain serving the lavatory or lavatories.

4. Where 2 bathtubs or showers and 2 water closets are served by the same wet vent a relief vent shall be provided, unless the wet vented horizontal drain connects to a drain stack with no other drain connections located above the wet-vented horizontal drain. The relief vent shall connect to the horizontal drain at a point downstream of the fixture drains for the water closets and upstream of any other fixture drain connections.

5. One or 2 water closets may connect to the common horizontal drain with the drain from the lavatories and bathtubs or showers also serving as a wet vent for the water closets. Where 2 water closets are served by the same wet vent, their fixture drains shall connect independently to the common horizontal drain at the same point.

6. The wet vent shall be at least 2" in diameter. No more than 4 drainage fixture units may discharge into a 2" diameter wet vent.

7. A branch vent shall connect immediately above the highest fixture drain connection and shall be sized in accordance with sub. (14).

(c) *Other types of wet vents.* An individual vent serving a floor outlet fixture, a common vent serving floor outlet fixtures, a circuit vent, a relief vent serving a circuit vented drain or a relief vent serving a wet vented horizontal drain may serve as a wet vent in accordance with subds. 1. to 4.

1. No more than 2 wall outlet fixtures, each fixture with a drainage fixture unit value of one or less, may have their fixture drains connected into the individual vent, common vent, circuit vent or relief vent.

2. The wet vent shall be at least 2" in diameter.

3. The branch vent to which the wet vent connects shall be sized in accordance with sub. (14). The branch vent may serve the wall outlet fixtures in lieu of individual vents or a common vent.

4. The fixtures discharging into the wet vent shall be located on the same floor level as the fixtures served by the wet vent.

**(14) VENT SIZE.** (a) *Stack vents and vent stacks.* Stack vent and vent stack pipe sizes shall be determined in accordance with Table 82.31-2 on the basis of developed length and the diameter of the drain stack at its base.

1. The developed length of the stack vent shall be measured along the vent pipe, from the highest drain branch connection to the vent terminal or to the connection to a vent header.

2. The developed length of the vent stack shall be measured along the vent pipe from the vent stack base connection to the vent terminal or to the connection to a vent header.

Note: See Appendix for further explanatory material.

(b) *Vent headers.* 1. Vent header pipe sizes shall be determined in accordance with Table 82.31-3 with the number of drainage fixture units being the sum of the fixture unit loads of the stacks vented through that portion of the header. The diameter of a vent header shall not be less than any vent connecting to it.

2. The developed length of the vent header shall be measured along the pipe from the most distant vent stack or stack vent base connection to the vent terminal.

Note: See Appendix for further explanatory material.

(c) *Branch vents.* Branch vent pipe sizes shall be determined in accordance with Table 82.31-3. The developed length of the branch vent shall be measured along the pipe from the furthest fixture drain served by the branch vent to the point where it connects to a vent pipe of a larger diameter or to a vent terminal.

Note: See Appendix for further explanatory material.

(d) *Individual vents.* Individual vent pipe sizes shall be determined in accordance with Table 82.31-3. The developed length of an individual vent shall be measured along the vent pipe from the fixture drain served by the vent to the point where it connects to a vent pipe of a larger diameter or to a vent terminal.

Note: See Appendix for further explanatory material.

(e) *Common vents.* Common vent pipe sizes shall be determined in accordance with Table 82.31-3. The developed length of a common vent shall be measured along the vent pipe from the drain served by the vent to the point where it connects to a vent pipe of a larger diameter or to the vent terminal.

**Table 82.31-2**  
**SIZE AND LENGTH OF VENT STACKS AND STACK VENTS**

Diameter of Drain Stack at Base (inches)	Maximum Developed Length of Vent (feet)									
	Diameter of Vent (inches)									
	1 1/4	1 1/2 <sup>a</sup>	2	3	4	5	6	8	10	12
1 1/2	50	150	NL <sup>b</sup>							
2	NP <sup>c</sup>	50	150	NL						
3		NP	50	400	NL					
4		NP	20	180	700	NL				
5			NP	50	200	700	NL			
6			NP	20	70	200	700	NL		
8				NP	25	60	250	800	NL	
10					NP	25	60	250	800	NL
12						NP	25	100	300	900

<sup>a</sup> Not more than 2 water closets or similar flush action type fixtures of 4 or more drainage fixture units.  
<sup>b</sup> NL means No Limit.  
<sup>c</sup> NP means Not Permitted.

**Table 82.31-3**  
**MINIMUM DIAMETERS AND MAXIMUM LENGTH OF INDIVIDUAL, COMMON, BRANCH AND CIRCUIT VENTS AND VENT HEADERS**

Drainage Fixture Units (dfu)	Maximum Developed Length of Vent (feet)									
	Diameter of Vent (inches)									
	1 1/4 <sup>a</sup>	1 1/2 <sup>b</sup>	2	3	4	5	6	8	10	
2	50	NL <sup>c</sup>								
4	40	200	NL							
8	NP <sup>d</sup>	150	250	NL						
10	NP	100	200	NL						
24	NP	50	150	NL						
42	NP	30	100	500	NL					
72		NP	50	400	NL					
240		NP	40	250	NL					
500		NP	20	180	700	NL				
1100			NP	50	200	700	NL			
1900			NP	20	70	200	700	NL		
3600				NP	25	60	250	800	NL	
5600					NP	25	60	250	800	800

<sup>a</sup> No water closets permitted.  
<sup>b</sup> Not more than 2 water closets or similar flush action type fixtures of 4 or more drainage fixture units.  
<sup>c</sup> NL means No Limit.  
<sup>d</sup> NP means Not Permitted.

(f) *Circuit vents.* Circuit vent pipe sizes shall be determined in accordance with Table 82.31-3. The developed length of the circuit vent shall be measured along the vent from the connection with the branch drain served by the vent to the point where it connects to a vent pipe of a larger diameter or to a vent terminal.

(g) *Relief vents.* Relief vents shall be sized in accordance with the provisions of subds. 1. to 4. The developed length of a relief vent shall be measured along the vent from the connection with the branch drain served by the vent to the point where it connects to a vent pipe of a larger diameter or to a vent terminal.

1. *Circuit vented branch drain.* The diameter of a relief vent for a branch drain served by a circuit vent shall be at least one half the diameter of the branch drain. The maximum developed length shall be determined from Table 82.31-3 based on the number of drainage fixture units served by the vent.

2. *Drain stacks.* A relief vent serving a drain stack shall be sized as a stack vent in accordance with par. (a).

3. *Building drain.* The diameter of a relief vent serving a building drain, as required in sub. (7), shall be at least one half the diameter of the building drain. The maximum developed length shall be determined from Table 82.31-3 based on the number of drainage fixture units served by the vent.

4. *Horizontal wet vent.* The diameter of a relief vent serving a horizontal wet vent shall be at least 1 1/2". The maximum developed length shall be determined from Table 82.31-3 based on the number of drainage fixture units served by the vent.

(h) *Yoke vents.* A yoke vent serving a drain stack shall be sized as a vent stack in accordance with par. (a).

(i) *Vents for sumps.* 1. a. Except as provided in subd. 1. b., the size of a vent for a sanitary pump with other than a pneumatic ejector, shall be determined in accordance with Table 82.31-4.

b. The size of a vent for a sanitary sump located outside with other than a pneumatic ejector shall be determined in accordance with Table 82.31-4, but shall not be less than 2" in diameter.

2. The air pressure relief pipe from a pneumatic ejector shall not be connected to vent or vent system serving a sanitary drain system, storm drain system or chemical waste system.

a. The relief pipe shall be of a size to relieve the air pressure inside the ejector to atmospheric pressure, but shall not be less than 2" in diameter where the ejector is located outside and 1 1/4" in diameter for all other ejector locations.

b. The vent shall terminate in accordance with the provisions of sub. (16).

(j) *Vents for chemical basins.* The size of vents serving chemical dilution or neutralizing basins shall be determined in accordance with Table 82.31-3 and based upon the number of drainage fixture units discharging into the basins.

(15) **VENT GRADES AND CONNECTIONS.** (a) *Vent grade.* All vent and branch vent pipes shall be graded and connected so as to drain back to a drain pipe by means of gravity.

(b) *Installation.* Vents shall be installed in accordance with subds. 1. to 3.

1. Except for wet vent piping, the connection of a vent to horizontal drain piping shall be at a point above the horizontal center line of the drain piping.

(b) *Waterproof flashings.* The penetration of a roof system by a vent shall be made watertight with an approved flashing.

(c) *Prohibited uses.* Vent terminals shall not be used as flag poles, support for antennas or other similar purposes.

(d) *Location of vent terminals.* 1. A vent shall not terminate under the overhang of a building.

2. All vent terminals shall be located:

a. At least 10 feet from an air intake;

b. At least 5 feet from a power exhaust vent;

c. At least 10 feet horizontally from or 2 feet above roof scuttles, doors and openable windows; and

d. At least 5 feet from or 2 inches above parapet walls.

3. Where a structure has an earth covered roof extending from surrounding grade, the vent extension shall run at least 7 feet above grade and terminate with an approved vent cap. The portion of vent pipe outside the structure shall be without joints, except one fitting may be installed where the pipe leaves the top or side of the structure.

(e) *Extension through wall.* Where approved by the department, a vent may terminate through an exterior wall. Such a vent shall terminate at least 10 feet horizontally from any lot line and shall terminate downward. The vent shall be screened and shall comply with par. (d).

(f) *Extensions outside buildings.* Drain or vent pipe extensions shall not be located or placed on the outside of an exterior wall of any new building, but shall be located inside the building.

(g) *Frost closure.* For protection against frost closure, each vent terminal shall be at least 2" in diameter. Where it is necessary to increase the diameter of the vent, the change in diameter shall be made at least 6" inside the building.

Note: See Appendix for further explanatory material.

(h) *Penetrations through grade.* Except when installation is in accordance with par. (d) 3., penetrations through grade shall terminate at least 12" above finished grade and terminate with a vent cap or return bend.

(17) **COMBINATION DRAIN AND VENT SYSTEMS.** In lieu of providing individual vents, fixtures may be vented in accordance with pars. (a) to (c).

(a) *Stacks.* 1. A drain stack may serve as a combination drain and vent system for fixtures in accordance with subd. 1. a. to f.

a. The drain stack shall not serve more than 3 fixtures. Each fixture shall be located on a separate floor level.

b. The drain stack shall be limited to serving fixtures with a drainage fixture unit value of no greater than 2.0. A urinal may not discharge into the combination drain and vent portion of the stack. The largest drainage fixture unit value served by the stack shall determine the stack size as specified in Table 82.31-5.

c. The drain stack shall not be offset horizontally above the lowest fixture drain connection.

d. The developed length of any fixture drain from the trap weir to the drain stack shall not exceed the limits specified in Table 82.31-1.

e. The drain stack and its attendant stack vent shall be sized in accordance with Table 82.31-5.

Note: See Appendix for further explanatory material.

**Table 82.31-5  
STACK SIZING BY DFU VALUE**

Drainage Fixture Unit (dfu) Value	Size of Stack (inches)
0.5	1 1/2
1.0	2
2.0	3

**Table 82.31-4**

**SIZE AND LENGTH OF VENTS FOR SANITARY SUMPS**

Discharge Capacity of Ejector (gpm)	Maximum Developed Length of Vent <sup>a</sup> (feet)				
	Diameter of Vent (inches)				
	1 1/4 <sup>d</sup>	1 1/2 <sup>d</sup>	2	3	4
10	NL <sup>b</sup>				
20	270	NL			
40	72	160	NL		
60	31	75	270	NL	
80	16	41	150	NL	
100	10	25	97	NL	
150	NP <sup>c</sup>	10	44	370	NL
200		NP	20	210	NL
250		NP	10	132	NL
300		NP	10	88	380
400			NP	44	210
500			NP	24	130

<sup>a</sup> The developed length of the vent is measured along the pipe from the connection to the sump, to the point where it connects to a vent pipe of a larger diameter.

<sup>b</sup> NL means No Limit.

<sup>c</sup> NP means Not Permitted.

<sup>d</sup> Diameter not permitted for exterior sumps.

2. Except as provided in subds. (12) and (17), vent piping serving a wall-outlet fixture may not offset horizontally less than 36" above the floor, but in no case lower than the elevation of the highest flood level rim of any fixture served by the vent.

3. Vent piping may not connect to a branch vent less than 38" above the floor, but in no case lower than 2" above the elevation of the highest flood level rim of any fixture served by the vent.

Note: See Appendix for further explanatory material.

(16) **VENT TERMINALS.** All vents and vent systems shall terminate in the open air in accordance with this subsection.

(a) *Extension above roofs.* Extensions of vents through a roof shall terminate at least 8" above the roof. Where the roof is to be used for any purpose other than weather protection, the vents shall extend at least 7 feet above the roof.

f. For the purpose of this subdivision a vent stack shall not be required to serve this type of combination drain and vent arrangement.

2. A drain stack may serve as a combination drain and vent system for a kitchen sink and a laundry tray in accordance with subd. 2. a. to d.

a. One kitchen sink within a dwelling unit, with or without a food waste grinder or dishwasher connection shall connect to the drain stack above the laundry tray. No other fixtures may connect to the drain stack.

b. The drain stack shall be at least 2" in diameter below the kitchen sink connection and it shall be at least 4" in diameter below the laundry tray connection.

c. In lieu of the minimum sizes as required in subd. 2. b., the entire stack below the kitchen sink connection may be 3" in diameter.

d. The drain stack shall not offset horizontally above the fixture drain connection for the laundry tray.

(b) *Building drains.* A building drain or a building subdrain may serve as a combination drain and vent system for floor drains and floor outlet fixtures in accordance with subds. 1. to 6.

1. A vent stack or a drain stack at least 2" in diameter shall be connected upstream of any building drain branch or building subdrain branch.

2. No more than 2 water closets may connect to the building drain or building subdrain by means of building drain branches or building subdrain branches.

3. a. That portion of the building drain or building subdrain between the connection of the building drain branch or building subdrain branch and the vent stack or drain stack required in subd. 1. shall be at least one pipe size larger than the minimum size permitted in Table 82.30-3 based on the total drainage fixture unit load.

b. The vent stack or drain stack required in subd. 1. shall be at least one-half the diameter of that portion of the building drain or building subdrain which is vented by the stack, but may not be less than 2" in diameter.

c. A stack vent serving a drain stack required in subd. 1. shall be at least one half the diameter of that portion of the building drain or building subdrain which is vented by the stack, but may not be less than 2" in diameter.

4. The trap of a floor drain or a floor outlet fixture, except a water closet, connected to a building drain branch or building subdrain branch shall be at least 3" in diameter.

5. A building drain branch or building subdrain branch may not connect to a building drain or building subdrain downstream from the base fitting of a drain stack 2" or larger in diameter within the distance equal to 20 pipe diameters of the building drain or building subdrain.

6. The pitch and the developed length of the building drain branch or building subdrain branch may not exceed the limits specified in Table 82.31-1.

Note: See Appendix for further explanatory material.

(c) *Laboratory sink venting.* A horizontal drain may serve as a combination drain and vent system for island laboratory sinks in accordance with subds. 1. to 7.

1. A vent stack or a drain stack at least 2" in diameter shall be connected upstream of any fixture drain vented by the combination drain and vent system.

2. a. That portion of the horizontal drain between the connection of fixture drain and the vent stack or drain stack required in subd. 1. shall be at least one pipe size larger than the minimum size permitted in Table 82.30-2 based on total drainage fixture unit load.

b. The vent stack or drain stack required in subd. 1. shall be at least one-half the diameter of that portion of the horizontal

drain which is vented by the stack, but may not be less than 2" in diameter.

c. A stack vent serving a drain stack required in subd. 1. shall be at least one half the diameter of that portion of the horizontal drain which is vented by the stack, but may not be less than 2" in diameter.

3. All fixture drains vented by the horizontal drain shall be at least 3" in diameter.

4. Fixture drains to be vented by the horizontal drain shall connect individually to the horizontal drain.

5. An individual vent or common vent shall be extended as high as possible under the sink enclosure and then returned vertically downward and connected to the horizontal drain. A cleanout shall be provided on the vent piping.

6. In lieu of connecting the vent to the horizontal drain which forms the combination drain and vent system, the vent may connect to a horizontal fixture drain vented by the combination drain and vent system. The pitch and developed length of the horizontal fixture drain shall not exceed the limits specified in Table 82.31-1.

7. Fixture drains to be vented by the horizontal drain shall not connect to a horizontal drain downstream from the base fitting of a drain stack 2" or larger in diameter within the distance equal to 20 pipe diameters of the horizontal drain serving the stack.

Note: See Appendix for further explanatory material.

(18) **PROHIBITED USES.** A vent or vent system shall not be used for purposes other than the venting of the plumbing system.

(a) *Boiler blowoff basin vents.* Vent piping from boiler blowoff basins shall not be connected to a vent or vent system serving a sanitary drain system, storm drain system or chemical waste system.

(b) *Chemical waste vents.* Vent piping for chemical waste systems shall not be connected to a vent system serving a sanitary drain system or storm drain system.

(c) *Steam vents.* Vents serving steam operated sterilizers, cleansing or degreasing equipment, pressing machines or any other apparatus which normally discharges steam into the vent shall not be connected to a vent or a vent system serving a sanitary drain system, storm drain system or chemical waste system.

**History:** Cr. Register, February, 1985, No. 350, eff. 3-1-85; am. (11) (a), (17) (b) 3. b. and (c) 2. b., r. and recr. (11) (b), r. (13) (a) 2., cr. (17) (b) 3. c. and (c) 2. c., Register, May, 1988, No. 389, eff. 6-1-88; reprinted to correct (17) (c) 4., Register, February, 1991, No. 422; cr. (4) (b) 4. and (17) (a) 1. f., r. and recr. (5) (c) 1. c. and (17) (c) 4., am. (5) (c) 2. c., (10) (intro.), (b) 1., (11) (b), (17) (a) 1. e. and (17) (b), Register, August, 1991, No. 428, eff. 9-1-91; am. (6) (c), (7) (b), (10) (intro.), (a), (b) 1., (e), (13) (a) 1. c., (c) (intro.), 1. and 4., r. (16) (h), Register, February, 1994, No. 458, eff. 3-1-94; CR 02-002: renum. (8) to be (8) (a) and am., cr. (8) (b), (14) (j) and (16) (h), am. (11) (a), (12) (intro.), (a), (13) (c) 1. (17) (a) 1. (intro.) to b., and Table 82.31-4, r. and recr. Table 82.31-5, Register April 2003 No. 568, eff. 5-1-03.

### Comm 82.32 Traps and direct fixture connections.

(1) **SCOPE.** The provisions of this section set forth the requirements for the types and installation of traps and direct fixture connections.

(2) **MATERIALS.** All traps and fixture connections shall be of approved materials in accordance with ch. Comm 84.

(3) **GENERAL.** Each plumbing fixture, each compartment of a plumbing fixture and each floor drain shall be separately trapped by a water seal trap, except as provided in par. (a) or as otherwise permitted by this chapter. A fixture shall not be double trapped.

(a) *Trap exceptions.* The plumbing fixtures listed in subds. 1. to 3. shall not be required to be separately trapped:

1. Fixtures having integral traps;

2. Compartments of a combination plumbing fixture installed on one trap, provided:

a. No compartment is more than 6" deeper than any other;

b. The distance between the compartments' waste outlets farthest apart does not exceed 30"; and

c. No compartment waste outlet is equipped with a food waste grinder.

3. Storm drains as provided in s. Comm 82.36 (14) (b).

(b) *Trap seals.* Each trap shall provide a liquid seal depth of not less than 2" and not more than 4", except as otherwise specified in this chapter.

(c) *Loss of trap seal.* A trap seal primer valve may be installed on a trap subject to high rates of evaporation.

1. A trap seal primer valve or other means of trap seal protection acceptable to the department shall be provided for a trap subject to seal loss due to evaporation.

**Note:** Liquids acceptable to use for reducing trap seal evaporation include mineral oil, vegetable oil, propylene glycol and glycerin.

2. Trap seal primer valves shall conform to ASSE 1018.

**Note:** A list of referenced standards is contained in ch. Comm 81.

(d) *Design.* Traps shall be self-scouring and shall not have interior partitions, except where such traps are integral with the fixture. Uniform diameter P-traps shall be considered self-scouring.

(e) *Size.* Traps shall be of diameters not less than those specified in Table 82.30-1 of s. Comm 82.30.

(f) *Prohibited traps.* The installation of the types of traps listed in subds. 1. to 6. shall be prohibited:

1. Bell traps;
2. Drum traps, except where specifically approved by the department;
3. S-traps which are not integral parts of fixtures;
4. Separate fixture traps which depend on interior partitions for the trap seal;
5. Traps which depend upon moving parts to maintain the trap seal; and
6. Traps which in case of defect would allow the passage of sewer air.

(4) **INSTALLATION.** (a) *Setting of traps.* All traps shall be rigidly supported and set true with respect to the water level and so located as to protect the water seals, and shall be protected from freezing and evaporation.

(b) *Distance from fixture drain outlets.* 1. Vertical distance. Except as provided in subd. 1. a. to c., the vertical distance between the top of the fixture drain outlet and the horizontal center line of the trap outlet shall not exceed 15".

a. The vertical distance between the top of the strainer of a floor drain or the opening of a standpipe receptor and the horizontal center line of the trap outlet shall not exceed 36".

b. The vertical distance between the top of the fixture drain outlet of a pedestal fixture or a cuspidor and the horizontal center line of the trap outlet shall not exceed 60".

c. The vertical distance between the water level in the bowl of a floor outlet water closet and the center line of the horizontal portion of the fixture drain shall not exceed 36".

d. The vertical distance from the inlet to the horizontal center line of the fixture drain for a campsite receptor, exterior storm drain inlet, or a receptor for a sanitary dump station may exceed 3 feet so as to permit the trap to be installed below the predicted depth of frost.

2. Horizontal distance. Except as provided in subd. 2. a. and b., the horizontal distance between the vertical centerline of a fixture drain outlet and the vertical centerline of the trap inlet shall not exceed 15".

a. The horizontal distance for a pedestal drinking fountain shall not exceed 24".

b. The horizontal distance for an exterior sanitary area drain or a residential garage floor drain discharging through an interior trap shall not exceed 25 feet.

**Note:** See Appendix for further explanatory material.

(5) **DIRECT FIXTURE DRAIN CONNECTION.** Except as provided in s. Comm 82.33, all plumbing fixtures and appliances discharging wastes shall connect directly to a drain system.

(a) *Floor drains.* 1. Floor drains shall be so located as to be accessible for cleaning purposes.

2. A floor drain receiving the wash from garbage cans shall be at least 3" in diameter.

(b) *Kitchen sinks.* Horizontal drain piping serving a kitchen sink trap shall not connect to vertical drain piping by means of a double sanitary tee.

(c) *Water closets.* A water closet shall discharge through a drain pipe or fitting with a minimum diameter of 3".

1. A floor mounted wall outlet water closet shall connect to a 4 inch or 4 x 3 inch closet collar fitting or to a horizontal or vertical carrier type fitting.

2. A floor outlet water closet shall connect to a 4 inch or 4 x 3 inch closet collar fitting. A 4 x 3 inch closet bend fitting may be installed where a 4 inch closet collar fitting is used.

3. A wall mounted wall outlet water closet shall connect to a horizontal or vertical carrier type fitting.

4. Two water closets discharging to a vertical drain from opposite sides by means of the same fitting shall be installed in accordance with subd. 4. a. and b.

a. Where the vertical drain is 3" in diameter, the fitting for floor outlet water closets shall be a 3 inch double wye pattern fitting.

b. Where the water closets are wall outlet types the fitting shall be a double wye pattern fitting or a carrier-type fitting.

(d) *Blowout-type fixtures.* Blowout-type plumbing fixtures shall be installed in accordance with the approval of the department.

**History:** Cr. Register, February, 1985, No. 350, eff. 3-1-85; am. (4) (a), cr. (5) (intro.) and (d), Register, May, 1988, No. 389, eff. 6-1-88; am. (4) (b) 1. b., Register, April, 2000, No. 532, eff. 7-1-00; CR 02-002: r. and recr. (3) (c) 1. and (4) (b) 2., am. (4) (b) 1. b., cr. (4) (b) 1. d., Register April 2003 No. 568, eff. 5-1-03; CR 02-129: am. (3) (intro.) Register January 2004 No. 577, eff. 2-1-04.

### Comm 82.33 Indirect and local waste piping.

(1) **SCOPE.** (a) The provisions of this section set forth the requirements for the installation of indirect waste piping and local waste piping.

(b) Indirect waste piping and local waste piping draining the fixtures, appliances and devices having a public health concern, including but not limited to those listed in Table 82.33-1, shall be considered as plumbing and shall comply with the provisions of this section.

**Table 82.33-1**

#### TYPES OF FIXTURES, APPLIANCES AND DEVICES OF A PUBLIC HEALTH CONCERN

Refrigerated food storage rooms and compartments	Coffee makers and urns
Refrigerated food display cases	Food processing equipment
Ice compartments	Baptismal fountains
Vending machines	Clothes washers and extractors
Steam tables and kettles	Dishwashers
Food preparation sinks	Stills
Potato peelers	Sterilizers
Egg boilers	Bar and soda fountains

#### Boiler blowoff basin outlet drains

(2) **MATERIALS.** Indirect waste piping more than 30" in length and all local waste piping shall be of approved materials in accordance with ch. Comm 84.

(3) **SIZE.** Except as provided in pars. (a) and (b), indirect waste piping more than 30" in length and all local waste piping shall be sized in accordance with s. Comm 82.30.

(a) Indirect or local waste piping not exceeding 20 feet in length for refrigerated food display cases may not be less than one inch in diameter.

(b) Indirect waste piping, attached to an appliance, appurtenance or equipment through which pressurized waste is discharged, shall be sized in accordance with specifications of the manufacturer of the appliance, appurtenance or equipment.

(4) **INSTALLATION.** Indirect waste piping and local waste piping shall be so installed as to permit access for flushing and cleaning.

(5) **TRAPS.** (a) *Indirect waste piping.* 1. Gravity flow indirect waste piping more than 30" in length shall be provided with a trap in accordance with s. Comm 82.32 (4), except indirect waste piping draining a sterilizer shall not be trapped.

2. All indirect waste piping draining a refrigerated food storage room, compartment or display case shall be provided with a trap in accordance with s. Comm 82.32 (4).

(b) *Local waste piping.* Local waste piping handling sanitary wastes and more than 30" in length shall be provided with a trap in accordance with s. Comm 82.32 (4).

(6) **MAXIMUM LENGTH.** Indirect waste piping and local waste piping handling sanitary wastes shall not exceed 30 feet in length horizontally nor 15 feet in length vertically.

Note: See Appendix for further explanatory material.

(7) **AIR-GAPS AND AIR-BREAKS.** All indirect waste piping and all local waste piping shall discharge by means of an air-gap or air-break into a receptor.

(a) *Air-gap installation.* 1. The distance of an air-gap between indirect waste piping one inch or less in diameter and the receptor shall be at least twice the diameter of the indirect waste piping.

2. The distance of an air-gap between indirect waste piping larger than one inch in diameter and the receptor shall be not less than 2".

(b) *Air-break installation.* The air-break between indirect waste piping or local waste piping and the receptor shall be accomplished by extending the indirect waste piping or local waste piping below the flood level rim of the receptor and terminating at an elevation above the trap outlet.

Note: See Appendix for further explanatory material.

(8) **RECEPTORS.** A receptor receiving the discharge from indirect waste piping or local waste piping shall be of a shape and capacity as to prevent splashing or flooding. Receptors shall be installed in accordance with this subsection and shall be accessible.

(a) *Waste sinks and standpipes.* A waste sink or a standpipe serving as a receptor shall have its rim at least one inch above the floor.

(b) *Floor sinks.* A floor sink serving as a receptor shall be equipped with a removable metal basket over which the indirect waste piping or local waste piping is to discharge, or the floor sink shall be equipped with a dome strainer. Indirect waste piping or local waste piping shall not discharge through a traffic grate, but shall terminate over an ungrated portion of the floor sink.

(c) *Local waste piping.* Local waste piping may not receive discharge from another local waste pipe.

(d) *Other receptors.* A plumbing fixture may not be used as a receptor for indirect or local waste piping, except as provided in subs. 1. to 5.

1. The indirect waste piping of a portable dishwasher or water treatment device serving one or 2 outlets may discharge into a kitchen sink of a dwelling unit or to a branch tail piece serving a kitchen sink.

2. The indirect waste piping of an automatic clothes washer or water treatment device may discharge into a laundry tray.

3. The indirect or local waste piping serving a cross connection control device or assembly, water treatment device, air conditioner, humidifier or furnace condensate may discharge into a branch tailpiece serving a laundry tray.

4. The local waste piping serving a water heater temperature and pressure relief valve, water treatment device, cross connection control device or assembly, humidifier, sterilizer, or a furnace or air conditioner may discharge into the riser of a floor drain when installed in accordance with sub. (7) (b).

5. The indirect or local waste piping serving a water heater temperature and pressure relief valve, water treatment device, cross connection control device or assembly, or a furnace or air conditioner may discharge to a floor served by a floor drain so as not to create a health or safety hazard.

Note: See Appendix A-82.33 (8) (a) to (d) for further explanatory material.

(9) **INDIRECT WASTE PIPING REQUIRED.** (a) *Boilers, pressure tanks and relief valves.* Boilers, pressure tanks, relief valves and similar equipment discharging to a drain system shall be by means of an air-gap.

1. Steam pipes shall not connect or discharge to any part of a plumbing system.

2. a. Except as provided in subd. 2. b., wastewater more than 160° F in temperature shall be discharged by means of indirect waste to the plumbing system.

b. Steam condensate blow down shall be cooled to 160°F in temperature prior to discharging to a plumbing system.

(b) *Clear water.* When discharging to a plumbing system, all clear water shall discharge by means of an air-gap.

(c) *Clothes washers.* 1. Residential types. Residential-type clothes washers shall discharge into the sanitary drain system by means of an air-break.

a. A standpipe receptor may not extend more than 36" nor less than 18" above the top of the trap weir.

b. A 1½-inch diameter standpipe receptor shall terminate at least 32" but not more than 48" above the floor on which the clothes washer is located.

c. A 2-inch or larger diameter standpipe receptor shall terminate at least 26" but not more than 48" above the floor on which the clothes washer is located. A 2-inch trap and fixture drain shall be installed downstream of the standpipe.

2. Self-service laundries. Pumped-discharge automatic clothes washing equipment in laundrettes, laundromats and self-service laundry establishments shall have the wastes discharge to a drain system by means of standpipes. The standpipes shall be installed in accordance with subd. 1.

a. The maximum number of washers which may be connected to a trap shall be in accordance with Table 82.33-2.

b. Washer wastes shall not be discharged to gutters, troughs, local waste piping, indirect waste manifold or other similar connections.

3. Commercial. Gravity discharge-type clothes washing equipment shall discharge by means of an air-break or by other approved methods into a floor receptor, trench or trough.

a. The receptor shall be sized to hold one full simultaneous discharge load from every machine draining into the receptor.

b. The size of the receptor drain shall be determined by the manufacturer's discharge flow rate and the frequency of discharge.

Note: See Appendix for further explanatory material.

c. All wastes from the washers shall flow through a Commercial laundry interceptor as specified in s. Comm 82.34.

Table 82.33-2

WASHER CONNECTIONS

Trap Diameter	Maximum Number of Washers
---------------	---------------------------



2 inches	2 machines
3 inches	3 machines
4 inches	4 machines

(d) *Dishwashing machines.* All dishwashing machines shall discharge to the sanitary drain system.

1. Residential type. The indirect waste piping from a residential-type dishwashing machine shall not exceed a developed length of 10 feet. The indirect waste piping from a residential-type dishwashing machine shall be installed in accordance with one of the following methods:

a. Where an air-gap or air-break is located below the counter top, the indirect waste piping from the dishwashing machine shall discharge to a standpipe. The standpipe shall be at least 1 ½ inches in diameter and shall extend at least 15 inches above the trap weir.

b. Where an air-gap or air-break is located above the counter top, the indirect waste piping from the dishwashing machine shall discharge to local waste piping. The local waste piping shall connect to the kitchen sink branch tailpiece above the trap inlet, the standpipe or to the dishwashing machine connection of a food waste grinder. When the local waste piping discharges to a stand pipe, the standpipe shall be at least 1 ½ inches in diameter and shall extend at least 15 inches above the trap weir. Where a hose is used for local waste piping, the developed length shall not exceed 18 inches.

2. Commercial. Commercial dishwashing machines shall discharge into a sanitary drain system by means of an air-gap or air-break into a trapped and vented receptor. The indirect waste piping may not be more than 30 inches in length.

(e) *Drips and drain outlets.* Appliances, devices and apparatus not defined as plumbing fixtures which have drip or drain outlets, which discharge to the plumbing system, shall discharge into an approved receptor by means of an approved air-gap or air-break.

(f) *Elevator drains.* 1. All drains serving elevator pits shall discharge to the storm drain system as specified in s. Comm 82.36 (3).

2. Drains serving elevator pits shall not connect directly with the storm drain system by means of gravity flow piping.

3. A sump may not be located in an elevator machine room.

4. A drain serving an elevator pit that discharges to a sump shall have a submerged inlet constructed to maintain a minimum 6" trap seal.

5. A sump located in an elevator pit may only receive storm or clear water waste from the elevator pit or the elevator machine room, or both.

Note: See Appendix for further explanatory material.

(g) *Food handling establishments.* Plumbing fixtures, devices and appurtenances installed in food handling establishments engaged in the storage, preparation, selling, serving or processing of food shall be installed in accordance with this paragraph.

1. Bar and soda fountain sinks. Where a bar or soda fountain sink is so located that the trap for the sink cannot be vented as specified in s. Comm 82.31, the sink drain shall discharge to the sanitary drain system through indirect waste piping.

a. Where the indirect waste piping is not trapped, the wastes shall be discharged by means of an air-gap.

b. Where the indirect waste piping is trapped, the wastes shall be discharged by means of an air-gap or air-break.

2. Beer taps, coffee makers, glass fillers and soda dispensers. The drip pan from a beer tap, coffee maker, glass filler, soda dispenser or similar equipment shall discharge to the sanitary drain system through indirect waste piping by means of an air-break or air-gap.

3. Novelty boxes, ice compartments and ice cream dipper wells. Novelty boxes, ice compartments and ice cream dipper wells shall discharge to the sanitary drain system through indirect waste piping by means of an air-gap.

a. The indirect waste piping shall not exceed 30" in length.

b. The indirect waste piping draining a novelty box or ice compartment may not discharge or connect to the indirect waste piping or local waste piping of any other fixture, appliance or device other than a novelty box or ice compartment.

4. Refrigerated food storage rooms, compartments and display cases. Drains serving refrigerated food storage rooms, compartments or display cases shall discharge to the sanitary drain system through indirect waste piping. The indirect waste piping shall drain by gravity to a receptor by means of an air-gap or air-break. Where an air-break is installed, the flood level rim of the receptor shall be at least 2" below the top of the fixture strainer or drain opening in the refrigerated room, compartment or display case.

5. Enclosed food processing equipment. Coffee urns, egg boilers, potato peelers, steam kettles, steam tables, vending machines and similar types of enclosed food processing equipment shall be discharged to the sanitary drain system through indirect waste piping by means of an air-gap.

6. Food preparation. Open culinary sink compartments for thawing or washing food shall discharge to the sanitary drain system through an independent connection by means of an air-gap. The fixture drain upstream of the air-gap shall not exceed a length of 30".

Note: See Appendix for further explanatory material.

(h) *Sterilizers.* Appliances, devices or apparatus, such as stills, sterilizers and similar equipment requiring waste connections and used for sterile materials, shall discharge through indirect waste piping to the sanitary drain system by means of an air-gap.

Note: See s. Comm 82.50 regarding sterilizer wastes.

(i) *Cross connection control devices or assemblies.* Where a receptor is provided, the vent port discharge from cross connection control devices or assemblies shall discharge to the receptor by means of an air-gap.

(j) *Vacuum systems—central units.* Central vacuum units shall discharge by means of an air-gap or air break.

(k) *Swimming pools.* 1. The backwash and drain wastewater from a swimming pool, wading pool or whirlpool shall discharge in accordance with Table 82.38-1.

2. The discharge from deck drains serving indoor pools shall be directed to the sanitary sewer via an air-gap.

3. The discharge from deck drains serving outdoor pools shall be directed to the storm sewer by way of an air-gap or to grade.

4. The requirements for sewer connections as specified in ch. Comm 90 applies to all public swimming pools.

(10) *WATER TREATMENT DEVICES.* (a) The waste discharge of a water treatment device to the drain system shall be protected in accordance with s. Comm 82.41 with respect to cross connection control.

Note: See Appendix A-82.30 (11) (d) for further explanatory material. Section NR 812.08 may require additional setbacks from wells for water treatment devices.

(b) The indirect waste piping or tubing from a water treatment device shall be of a material conforming to one or more of the standards listed in Tables 84.30-8 or 84.30-11.

Note: For appliances, devices and equipment not included in this section or other sections contact the department for information and proposed installation review.

History: Cr. Register, February, 1985, No. 350, eff. 3-1-85; r. and recr. Table 82.33-1 and (9) (g) 5., cr. (8) (c) 3., (9) (g) 6. and (k), Register, May, 1988, No. 389, eff. 6-1-88; r. and recr., (3), am. (9) (c) 1. a., (d) 2. and (g) 4., Register, August, 1991, No. 428, eff. 9-1-91; am. (8) (d) 1., 2. and (9) (g) 3. b., r. (9) (k), cr. (10), Register, February, 1994, No. 458, eff. 3-1-94; correction in (9) (i) 5., made under s. 13.93 (2m) (b) 7., Stats., Register, February, 1994, No. 458; r. and recr. (9) (f), Register, April, 1998, No. 508, eff. 5-1-98; correction in (9) (i) 5., made under s. 13.93 (2m) (b) 7., Stats., Register, April, 1998, No. 508; r. and recr. (9) (f), cr. Table 82.33-3, Register, December, 2000, No. 540, eff. 1-1-01; CR 02-002: am. (5) (a) 2., (7) (b), (9) (c) 1. b., (e), (g) 6., renum. (8) (a) 1., (9) (a) 2. and (10) to be (8) (a), (9) (a) 2. a. and (10) (a) and am. (9) (a) 2. a., r. (8) (a) 2., r. and recr. (8) (c), (d), (9) (b), (d) 1. and (i), cr. (9) (a) 2. b., (c) 1. c., and (10) (b) Register April 2003 No. 568, eff. 5-1-03; CR 02-129: am. (9) (c) 1. b., r. (9) (d) 3. and table 82.33-3, cr. (9) (k) Register January 2004 No. 577, eff. 2-1-04.

**Comm 82.34 Wastewater treatment devices.**  
(1) **SCOPE.** The provisions of this section set forth the requirements for design and installation of plumbing wastewater treatment devices, appurtenances and systems, including but not lim

ited to interceptors, catch basins, and dilution and neutralizing basins.

(2) **MATERIALS.** All piping, devices and appliances for waste water treatment devices, appurtenances and systems shall be of approved materials in accordance with ch. Comm 84.

(3) **GENERAL.** Any deleterious waste material which is discharged into a plumbing system shall be directed to a wastewater treatment device. The wastewater treatment device shall be capable of separating, diluting or neutralizing the deleterious waste material to a degree that the wastewater is no longer deleterious. Wastewater treatment devices that retain any waste materials shall be designed and installed to facilitate periodic removal or treatment, or both.

(a) *Treatment for reuse.* 1. Except as provided in subd. 2., wastewater discharged from water closets or urinals shall not be reused for drinking water or treated for reuse.

2. All treatment works permitted by the department of natural resources, or a POWTS which includes an in situ soil dispersal or treatment component may treat wastewater discharged from water closets or urinals for reuse.

(b) *Deleterious waste materials.* For the purpose of this sub section, deleterious waste materials include any waste material, other than that from dwelling units, which may:

1. Congeal, coagulate or accumulate in drains and sewers, thereby, creating stoppages or retarding the discharge flow;

2. Retard or interfere with municipal sewage treatment processes;

3. Pass through a treatment process and pollute the water course receiving the treatment effluent;

4. Create explosive, flammable, noxious, toxic or other hazardous mixtures of materials; or

5. Damage, destroy or deteriorate sewers or piping materials or structures.

**Note:** See ch. Comm 10 as to flammable and combustible liquids.

(c) *Private disposal systems.* The special or industrial wastes from any plumbing system which are not discharged into a public sewer system shall be treated or disposed in compliance with the rules of the state agency having jurisdiction. The treatment or disposal system shall be installed so as not to endanger any water supply which is or may be used for drinking, culinary or bathing purposes, or which may create a nuisance, unsanitary conditions or water pollution.

(d) *Velocity control.* Interceptors, catch basins and other similar devices shall be designed, sized and installed so that flow rates shall be developed and maintained in a manner that solid and floating materials of a harmful, hazardous or deleterious nature will be collected in the interceptor for disposal.

(e) *Maintenance.* All devices installed for the purpose of intercepting, separating, collecting, or treating harmful, hazardous or deleterious materials in liquid or liquid-borne wastes shall be operated and cleaned of intercepted or collected materials or of any residual from treatment at such intervals which may be required to prevent their passage through the interceptor.

(f) *Service reassembly.* Any fixed orifice, vent or trap of an interceptor, catch basin or other similar device shall remain intact and shall not be removed or tampered with except for cleaning purposes. After service, all parts of the interceptor, collector or treatment device, such as baffles, weirs, orifice plates, channels, vents, traps, tops, and fastening bolts or screws shall be replaced in proper working position.

(g) *Location.* 1. Interceptors, catch basins and other similar devices shall be accessible for service, maintenance, repair and inspection.

a. No interceptor, catch basin or similar device may be surrounded or covered as to render it inaccessible for service or inspection.

b. No interceptor, catch basin or similar device may have its top located more than 6 feet above the surrounding floor.

c. Enough space shall be provided to enable the removal of any interior parts of the interceptor, catch basin or similar device.

d. At least 18" of clear space shall be provided above the top of the interceptor, catch basin or similar device.

2. An interceptor, catch basin, or similar device shall not be located within 25 feet of a water well.

(h) *Disposition of retained materials.* Deleterious waste materials retained by an interceptor, catch basin or similar device shall not be introduced into any drain, sewer or natural body of water without approval of the state agency having jurisdiction.

(4) **GARAGE FLOOR AREA WASTEWATER.** (a) *Garages for public buildings and facilities.* 1. Where a drain will be installed to receive the wastewater from floor areas of public buildings and facilities on which self-propelled land, air or water vehicles can be driven, the wastewater shall discharge using one of the following methods:

a. In areas where vehicles will be serviced, the wastewater shall discharge through a garage catch basin or oil interceptor connected to a municipal sewer or holding tank approved to receive industrial wastewater.

b. In areas where vehicles will be driven or stored, the wastewater shall discharge through a floor drain equipped with a solid bottom sediment bucket, garage catch basin or oil interceptor.

2. Garage catch basins design shall conform to all of the following:

a. The holding area of the catch basin shall be watertight.

b. The catch basin shall have a minimum inside diameter of 36".

c. The minimum depth of the basin shall be 24" measured from the lowest portion of the trap on the outlet of the basin.

d. The outlet of the basin shall be at least 4" in diameter and trapped with a water seal of at least 6" and constructed on the interior or exterior of the basin. Where an external trap is provided, the trap shall be within 36" of the basin.

e. Except as provided in subd. 5., the water line in the basin shall be at least 2" below all horizontal drains discharging into the basin. Where an external trap is provided, the measurement point on the horizontal drain shall be upstream of the trap.

f. The basin shall be provided with a cover at least 24" square or 24" in diameter.

g. Gravity drains from fixtures serving garage floor areas located on different floors from the basin may discharge into the basin if the drain stack carrying the wastewater is located at a distance equal to at least 20 times the inside diameter of the horizontal piping upstream of the basin.

h. Catch basins with solid covers shall be vented in accordance with sub. (8) (c).

3. Drains with traps may connect to the garage catch basin under all of the following conditions:

a. The trap shall be a minimum of 3" in diameter.

b. Except as provided in subd. 3. c., the developed length from all trap outlets to the basin shall not exceed the distance as specified in Table 82.31-1.

c. Where the maximum distance exceeds that as specified in Table 82.31-1, the trap shall be vented in accordance with s. Comm 82.31 (3) and the connection to the basin shall form a 6-inch trap seal. The trap seal may be constructed on either the interior or exterior of the basin, but within 36" of the basin.

4. Drains without traps may discharge into a garage catch basin under all of the following conditions:

a. The fixture drain shall have a minimum 4-inch inside diameter.

b. The fixture drain shall be piped with a 6-inch water seal constructed either on the interior or exterior of the basin.

c. An exterior trap shall be constructed within 36" of the basin.

d. The developed length of the fixture drain shall not exceed the distance equal to 24 times the diameter of the fixture drain.

e. Fixture drains shall individually discharge into a garage catch basin.

5. Pressurized drains from garage floor areas discharging to a garage catch basin shall conform to all of the following conditions:

a. The pressurized drain piping shall terminate inside the basin with a 6-inch submerged inlet. The termination shall be at least 12" above the floor of the basin.

b. The pressurized equipment, devices and piping shall be designed and installed to produce a maximum velocity of 2 feet per second at the point of connection to the basin.

*Note:* Plans for garage floor discharge-holding tanks may require plan approval by the department of natural resources.

(b) *Garages for one- and 2-family dwellings.* 1. Floor drains serving garages for one- and 2-family dwellings shall be provided with a solid bottom sediment basket.

*Note:* See Appendix for further explanatory material.

2. Catch basins serving garages for one- and 2-family dwellings shall be designed and installed in accordance with par. (a) 2.

(c) *Grates for garage catch basins, floor drains and trenches.* A garage catch basin, floor drain and trench drain shall be provided with an approved, removable cast iron or steel grate of a thickness and strength for the anticipated loads. The grate shall have an available inlet area equal to at least the outlet drain for the catch basin, floor drain or trench drain.

(5) **GREASE INTERCEPTORS.** All plumbing installations for occupancies, other than dwelling units, where grease, fats, oils or similar waste products of cooking or food are introduced into the drain system shall be provided with interceptors in accordance with this subsection. All drains and drain piping carrying oil, grease or fats shall be directed through one or more interceptors as specified in par. (a).

(a) *General.* 1. Public sewers. All new, altered or remodeled plumbing systems which discharge to public sewers shall be provided with one or more exterior grease interceptors or one or more interior grease interceptors.

a. Where one or more exterior grease interceptors are provided all and only kitchen wastes shall be discharged to an exterior interceptor.

b. Where one or more interior grease interceptors are provided the wastes from a food waste grinder or a sanitizing compartment of a sink, or both, may bypass the interceptor or interceptors.

2. Private onsite wastewater treatment systems. All new, altered or remodeled plumbing systems which discharge to private onsite wastewater treatment systems shall be provided with exterior grease interceptors.

a. Except as provided in subd. 2. b., only kitchen and food wastes shall be discharged to an exterior grease interceptor.

b. Where approved by the department combined kitchen wastes and toilet wastes may be discharged directly to a septic tank or tanks which conform to par. (b). The required capacity of a grease interceptor shall be added to the required septic tank capacity as specified in ch. Comm 83.

3. Existing installations. The department may require the installation of either interior or exterior interceptors for existing plumbing installations where the waterway of a drain system, sewer system or private onsite wastewater treatment system is reduced or filled due to congealed grease.

(b) *Exterior grease interceptors.* Exterior grease interceptors shall receive the entire waste discharge from kitchens or food processing areas. All exterior interceptors shall be designed and

constructed in accordance with this paragraph, so as to constitute an individual structure.

1. Design. a. The liquid depth of the interceptor shall not be less than 42" nor more than an average of 72".

b. A rectangular interceptor tank shall have a minimum width of 36" and a minimum length of 72". The longest dimension of the tank shall be parallel to the direction of waste flow.

c. A horizontal-cylindrical interceptor tank shall have a minimum inside diameter of 52" and a minimum length of 72". The longest dimension of the tank shall be parallel to the direction of waste flow.

d. Vertical-cylindrical interceptor tanks shall have a minimum inside diameter of 72".

e. Each prefabricated interceptor tank shall be clearly marked to indicate liquid capacity and the name and address or registered trademark of the manufacturer. The markings shall be impressed into or embossed onto the outside wall of the tank immediately above the outlet opening. Each site-constructed concrete tank shall be clearly marked at the outlet opening to indicate the liquid capacity. The marking shall be impressed into or embossed onto the outside wall of the tank immediately above the outlet opening.

f. The inlet and outlet openings of interceptor tanks or tank compartments shall be provided with, open-end sanitary tee fittings or baffles, so designed and constructed as to distribute the flow and retain the grease in the tank or tank compartments. The sanitary tee fittings or baffles shall extend at least 6" above the liquid level. At least 2" of clear space shall be provided above the top of the sanitary tee fittings or baffles. The sanitary tee fitting or baffle at the inlet opening shall extend below the liquid level of the tank a distance equal to  $\frac{1}{3}$  of the total liquid depth. The sanitary tee fitting or baffle at the outlet opening shall extend below the liquid level of the tank a distance equal to  $\frac{2}{3}$  of the total liquid depth. The waterline in the interceptor shall be at least 2" below the horizontal drain discharging to the interceptor.

g. Each compartment of an interceptor tank shall be provided with at least one manhole opening located over either the inlet or outlet opening. Additional manhole openings shall be provided such that no interior compartment wall of a tank is more than 4 feet from the edge of the manhole opening. The distance between manhole openings serving the same compartment shall not exceed 8 feet. Manhole openings shall be not less than 23" in the least dimension. Manholes shall terminate at or above ground surface and be of approved materials. Steel tanks shall have a minimum 2" collar for the manhole extensions permanently welded to the tank. The manhole extension on fiberglass tanks shall be of the same material as the tank and an integral part of the tank. The collar shall have a minimum height of 2".

h. Manhole risers for interceptor tanks shall be provided with a substantial, fitted, watertight cover of concrete, steel, cast iron or other approved material. Manhole covers shall terminate at or above grade and shall have an approved locking device.

i. A minimum 4 x 6 inch permanent label shall be affixed to the manhole cover, identifying the interceptor tank with the words GREASE INTERCEPTOR. Where the tank acts as the septic tank and grease interceptor the label shall identify it as such. The wording used on the warning label shall be approved by the department, as part of the materials approval for the tank under ch. Comm 84.

j. An inlet or outlet opening which does not have a manhole opening as specified in subd. 1. g. shall be provided with an air tight inspection opening located over the inlet or outlet. The inspection opening shall be at least 4" in diameter. The inspection opening shall terminate at or above grade.

*Note:* See Appendix for further explanatory material.

2. Capacity and sizing. The minimum liquid capacity of a grease interceptor shall be determined in accordance with the provisions of this subdivision, except no grease interceptor may have a capacity of less than 1000 gallons if the interceptor is to discharge to a private onsite wastewater treatment system or less than

750 gallons if the interceptor is to discharge to a municipal sewer system and treatment facility.

a. The minimum capacity of a grease interceptor serving a restaurant with seating shall be equal to C, where

$$C = S \times H \times A$$

where, S = Number of seats, with each drive-in car service space counting as 3 seats and each drive-up service window counting as 60 seats.

H = Hours per day that meals are served, at least 6 hours but not more than 12 hours.

A = Appliance factor:

0.75 for a kitchen with no dishwashing machine and no food waste grinder.

1.0 for a kitchen with either a dishwashing machine or a food waste grinder.

1.25 for a kitchen with both a dishwashing machine and a food waste grinder.

b. The minimum capacity of a grease interceptor serving a dining hall, hospital, nursing home, school kitchen, church kitchen or a kitchen for carryout or delivery service shall be equal to C, where:

$$C = \frac{M \times G \times H}{2 \times P}$$

where, M = Meals served per day.

G = 3 gallons per meal served.

H = Hours per day that meals are served, at least 6 hours but not more than 12 hours.

P = Meal periods per day; 1, 2 or 3.

c. The minimum capacity of a grease interceptor as determined in subd. 2. a. or b. may be halved for establishments with all paper service, but may not be less than 1000 gallons if the interceptor is to discharge to a private sewage system or less than 750 gallons if the interceptor is to discharge to a municipal sewer system and treatment facility.

3. Installation. a. Grease interceptor tanks may not be located within 5 feet of a building or any portion of the building or swimming pool; 10 feet of a water service; 2 feet of a lot line; 10 feet of a cistern or 25 feet of a reservoir or high water mark of a lake, stream, pond or flowage.

Note: The department of natural resources under ch. NR 113 requires a minimum setback of 25 feet between a grease interceptor and a well.

b. Where a grease interceptor tank is installed in groundwater, the tank shall be adequately anchored.

c. Grease interceptor tanks shall be installed on a bedding of at least 3" in depth. The bedding material shall be sand, gravel, granite, limerock or other noncorrosive materials of a size that all will pass through a 3/4" sieve.

d. The backfill material for steel and fiberglass grease interceptor tanks shall be as specified in subd. 3. c. for bedding and shall be tamped into place. The backfill material for concrete grease interceptor tanks shall be soil material, of a size that will pass through a 4 inch screen and shall be tamped into place.

e. All joints on concrete risers and manhole covers for a grease interceptor shall be tongue and groove or shiplap type and sealed watertight using neat cement, mortar or bituminous compound. All joints on steel risers for a grease interceptor shall be welded or flanged and bolted and be watertight. All steel manhole extensions from a grease interceptor shall be bituminous coated inside and outside. All methods of attaching fiberglass risers for a grease interceptor shall be watertight and approved by the department.

Note: See Appendix A-82.30 (11) (d) for material reprinted from s. NR 812.08. Section NR 812.08 may have additional setback requirements to wells.

(c) *Interior grease interceptors.* 1. Flow rating. An interior grease interceptor shall be capable of accommodating a flow of at least 15 gallons per minute, but not less than the manufacturer's specifications.

2. Flow rate related to connected capacity. Three-fourths of the total holding capacity in gallons of all fixtures and devices discharging to an interior grease interceptor, shall not exceed the value of the maximum flow rate which the interceptor can accommodate.

3. Grease holding capacity as related to flow rate. The grease holding capacity in pounds shall not be less than double the value of the maximum flow rate which the interceptor can accommodate.

4. Flow controls. Where required by the manufacturer, devices which control the rate of flow through an interior grease intercept shall be installed.

a. The flow control devices shall be accessible for inspection, service and cleaning.

b. Flow controls shall be installed in the drain branch leading to each fixture and shall be so rated that the combined flow from all combinations of discharge will not develop either sufficient static or velocity head so the established flow rate of the interceptor can be exceeded.

Note: See Appendix for further explanatory material.

5. Flow control vents. Orifice type flow controls for an interior grease interceptor shall be vented in accordance with s. Comm 82.31.

6. Prohibited locations and types. No water-cooled grease interceptor may be installed. No grease interceptor may be located where the surrounding temperatures, under operating conditions, are less than 40° F.

(d) *Prohibited treatment.* The introduction of grease or fat emulsifiers into a grease interceptor shall be prohibited.

(6) **AUTOMATIC CAR WASHES.** The wastes of floor drains and drain inlets of automatic car washes shall discharge through an approved car wash interceptor.

(a) *Design.* Except as provided in subds. 1. and 2. and par. (b), car wash interceptors shall be constructed and installed in accordance with sub. (4) (a) 2.

1. The interceptor's outlet shall be submerged to form a trap with a water seal of at least 15".

2. The bottom of the trap's water seal shall be at least 30" above the bottom of the interceptor.

(b) *Capacity.* The minimum liquid capacity of the interceptor shall be based on the maximum flow rate of water through the interceptor in gallons per minute.

1. Between the waterline and the bottom of the trap seal of the outlet, the interceptor shall have a capacity value equal to at least 5 times the maximum flow rate.

2. Below the bottom of the trap seal of the outlet, the interceptor shall have a capacity value equal to at least 15 times the maximum flow rate.

Note: See Appendix for further explanatory material.

(c) *Hand-held car washing wands.* The wastes of floor drains and drain inlets serving 2 or more hand-held car washing wands shall discharge through an approved car wash interceptor. The wastes of one hand-held car washing wand may discharge to a garage catch basin.

(d) *Recirculated water.* Where recirculated water is used for washing, the recirculated water shall be drawn from a separation chamber located upstream from the car wash interceptor.

(7) **COMMERCIAL LAUNDRIES.** Wastes from gravity dump-type clothes washing equipment shall be discharged through an approved laundry interceptor in accordance with this subsection.

(a) *Screening apparatus.* A laundry interceptor shall be equipped with a wire basket or other device which will prevent the

passage of solids, 1/2" or larger in diameter, string, buttons and other detrimental materials into the drain system.

(b) *Trench type interceptors.* A floor receptor, trench or trough as specified in s. Comm 82.33 (9) (c) 3., may serve as a laundry interceptor, if no oils or quantities of sand are discharged into it.

Note: See Appendix for further explanatory material.

(c) *In-line interceptor.* 1. In-line interceptors shall have a minimum inside diameter or horizontal dimension of 24".

2. An in-line interceptor shall be provided with an air-tight cover.

3. An in-line interceptor shall be provided with a vent.

a. The vent shall extend from above the flow line to a vent terminal in accordance with s. Comm 82.31 (16) or shall be connected to the venting system serving the sanitary drain system.

b. The diameter of the vent shall be at least one-half of the diameter of the interceptor's outlet, but not less than 2".

4. The outlet for an in-line interceptor shall be at least 4" in diameter. The outlet shall be submerged to form a trap with a water seal of at least 12". The bottom of the trap's water seal shall be at least 12" above the bottom of the interceptor.

5. The waterline in an in-line interceptor shall be at least 2" below the bottom of the inlet opening for the interceptor.

(8) **OIL AND FLAMMABLE LIQUIDS.** Oily and flammable waste water that discharges to a building sewer shall be intercepted or treated by a means acceptable to the department.

(a) *Site-constructed interceptors.* Site-constructed interceptors shall be designed in accordance with the requirements in sub. (4) (a) 2.

(b) *Prefabricated oil interceptors and separators.* Prefabricated oil interceptors and separators shall be manufactured with adequate capacity for the anticipated load.

(c) *Venting.* Oil and flammable interceptors and separators shall be so designed to prevent the accumulation of explosive gases.

1. A covered interceptor or separator shall be provided with an individual vent of at least 3 inches in diameter. The vent shall extend from the top of the interceptor or separator or as high as possible, from the side of the interceptor or separator to a point at least 12 feet above grade.

2. The drain pipe to the interceptor or separator shall be provided with a fresh air inlet connected within 2 feet of the inlet of the interceptor or separator. The fresh air inlet shall terminate at least one foot above grade, but not less than 6 feet below the terminating elevation of the vent serving the interceptor or separator. The fresh air inlet shall be at least 3 inches in diameter.

Note: See Appendix for further explanatory material.

(9) **BOTTLING ESTABLISHMENTS.** Wastes containing glass of bottling establishments shall be discharged through an interceptor.

(10) **DAIRY PRODUCT PROCESSING PLANTS.** Dairy wastes from dairy product processing plants shall be discharged through an interceptor.

(11) **MEAT PROCESSING PLANTS AND SLAUGHTERHOUSES.** The wastes from meat processing areas, slaughtering rooms and meat dressing rooms shall be discharged through an approved interceptor to prevent the discharge of feathers, entrails, blood and other materials.

(12) **SAND INTERCEPTORS.** Sand interceptors and other similar interceptors for heavy solids shall be so designed and located as to be accessible for cleaning. The outlet for the interceptor shall be submerged to form a trap with a water seal of at least 12".

(13) **PLASTER AND HEAVY SOLIDS TRAP TYPE INTERCEPTORS.** Plaster sinks shall be provided with plaster and heavy solids trap type interceptors.

(a) The interceptor shall be installed as the fixture trap.

(b) The drain piping between the sink and the interceptor shall not exceed a length of 36".

Note: See Appendix for further explanatory material.

(14) **CHEMICAL WASTE PIPING SYSTEMS.** All chemical wastes having a pH level of less than 5.5 or more than 10.0 shall discharge to a holding tank for proper disposal or to a drain system in accordance with this subsection.

(a) *Chemical dilution and neutralizing basins.* 1. All chemical wastes discharging into a drain system shall be diluted, neutralized or treated to a pH level of 5.5 to 10.0 by passing through an approved dilution or neutralizing basin before discharging to a building sewer.

2. Dilution and neutralizing basins shall have the minimum retention capacities as specified in Table 82.34. For quantities of fixtures exceeding 150 sinks or for special uses or installations, the department shall be consulted as to the minimum capacity of the basin.

3. Where a sufficient supply of diluting water cannot be provided to a dilution or neutralizing basin, the basin shall be filled with marble or limestone chips of not less than one inch nor more than 3" in diameter to the level of the basin's outlet.

4. Either the inlet or outlet of a dilution or neutralizing basin shall be submerged to form a trap with a water seal of at least 4".

Table 82.34

**MINIMUM CAPACITIES FOR DILUTION AND NEUTRALIZING BASINS**

Maximum Number of Sinks	Minimum Retention Capacity in Gallons
1	5
4	15
8	30
16	55
25	100
40	150
60	200
75	250
100	350
150	500

(b) *Vents.* Vents for chemical waste systems shall be sized and installed in accordance with all of the following:

1. Dilution and neutralizing basins with submerged inlets shall have a sanitary vent connected to the basin and a chemical waste vent connected to the inlet pipe. The pitch and the developed length of the drain between the submerged basin inlet and the chemical waste vent shall be in accordance with Table 82.31-1.

2. Dilution and neutralizing basins with submerged outlets shall have a chemical waste vent connected to the basin and a sanitary vent connected to the outlet pipe. The pitch and the developed length of the drain between the submerged basin outlet and the sanitary vent shall be in accordance with Table 82.31-1.

Note: See Appendix for further explanatory material.

3. The vents for a chemical waste basin shall be sized based on the number of drainage fixture units discharging into the basin and installed in accordance with s. Comm 82.31.

History: Cr. Register, February, 1985, No. 350, eff. 3-1-85; am. (4) (a) 2. b., (5) (b) 2. intro., c. and (c) 4. b., Register, August, 1991, No. 428, eff. 9-1-91; am. (4) (a) 2. c. and g., 3. a., (5) (b) 1. f. and j., 3. a., (c) 1., (8) (a) 2. c., r. and recr. (5) (a) 1., r. (5) (b) 3. e. and (c) (intro.), renum. (5) (b) 3. f. to be (5) (b) 3. e., Register, February, 1994, No. 458, eff. 3-1-94; am. (5) (a) 2. (intro.), 3. and (b) 2. (intro.), Register, April, 2000, No. 532, eff. 7-1-00; am. (4) (b) 2., Register, December, 2000, No. 540, eff. 1-1-01; CR 02-002: r. and recr. (1), (2), (4) (a), (8) (a) and (b), am. (3) (intro.), (6) (a) (intro.) and (14) (b) (intro.), renum. (3) (a) to (f) to be (3) (b) to (g), cr. (3) (a) and (14) (b) 3., r. (3) (g), Register April 2003 No. 568, eff. 5-1-03; CR 02-129: am. (4) (a) 2. b. and (5) (b) 1. g. Register January 2004 No. 577, eff. 2-1-04.

**Comm 82.35 Cleanouts.** (1) **SCOPE.** The provisions of this section set forth the requirements for the installation of cleanouts and manholes for all drain piping.

(2) **MATERIALS.** Cleanouts shall be constructed of approved materials in accordance with ch. Comm 84.

(3) WHERE REQUIRED. (a) *Horizontal drains.* All gravity horizontal drains within or under a building shall be accessible through a cleanout. The developed length of drain piping between cleanouts may not exceed 75 feet. For the purpose of this requirement, cleanouts in drain stacks may serve horizontal drains.

Note: See Appendix for further explanatory material.

(b) *Sanitary building sewers.* 1. Sanitary building sewers 6" or less in diameter shall be provided with cleanouts or manholes such that:

- a. Cleanouts are located not more than 100 feet apart;
- b. Manholes are located not more than 400 feet apart;
- c. The distance from a cleanout to a manhole located upstream is not more than 200 feet; or
- d. The distance from a manhole to a cleanout located upstream is not more than 300 feet.

2. Sanitary building sewers 8" or larger in diameter shall be provided with manholes at:

- a. Every change in direction of 45° or more;
- b. Every change in pipe diameter; and
- c. Intervals of not more than 400 feet.

(c) *Storm building sewers.* 1. Storm building sewers 10" or less in diameter shall be provided with cleanouts or manholes such that:

- a. Cleanouts are located not more than 100 feet apart;
- b. Manholes are located not more than 400 feet apart;
- c. The distance from a cleanout to a manhole located upstream is not more than 200 feet; or
- d. The distance from a manhole to a cleanout located upstream is not more than 300 feet.

2. Storm building sewers 12" or larger in diameter shall be provided with manholes or storm drain inlets with an inside diameter of at least 36" at:

- a. Every change in direction of 45° or more;
- b. Every change in pipe diameter; and
- c. Intervals of not more than 400 feet.

(d) *Private interceptor main sewers.* 1. Private interceptor main sewers 5" or less in diameter shall be provided with an exterior cleanout or manhole upstream of the point of the creation of the private interceptor main sewer and such that:

- a. Cleanouts are located not more than 100 feet apart;
- b. Manholes are located not more than 400 feet apart;
- c. The distance from a cleanout to a manhole located upstream is not more than 200 feet; or
- d. The distance from a manhole to a cleanout located upstream is not more than 300 feet.

2. Private interceptor main sewers 6" or larger in diameter shall be provided with a manhole at:

- a. The most upstream point of the private interceptor main sewer;
- b. Every change in direction;
- c. Every change in pipe diameter; and
- d. Intervals of not more than 400 feet.

(e) *Junction of building drain and building sewer.* A cleanout shall be provided near the junction of a building drain and a building sewer.

1. The cleanout shall be located within 5 feet of where the building drain and the building sewer connect. The cleanout may be located either inside or outside the building.

2. A cleanout in a drain stack may serve as the cleanout at the junction of the building drain and building sewer, if the stack is within 5 feet of where the building drain and building sewer connect.

(f) *Stacks.* Where a cleanout is provided in a drain stack, the cleanout shall be located 28 to 60 inches above the lowest floor penetrated by the stack.

(g) *Branches.* 1. Except as provided in subd. 2., cleanouts shall be provided in connection with batteries of fixtures at such points that all parts of the branch drain may be accessible for cleaning or removal of stoppages. For the purposes of this requirement, removable fixture traps may serve as cleanout openings.

2. A cleanout shall not be required for a branch drain when the fixtures on the branch include one floor outlet fixture and any fixtures discharging into an accompanying wet vent.

(h) *Greasy wastes.* Drain pipes carrying greasy wastes shall be provided with cleanouts located not more than 40 feet apart and at all changes in direction of more than 45°.

(i) *Double sanitary tees.* A cleanout shall be provided immediately above or below a double sanitary tee drain fitting which is installed in a vertical drain pipe of less than 3" in diameter, unless a stack cleanout is provided in accordance with par. (f).

(j) *Traps and fixture drains.* 1. All traps shall be constructed or installed so that stoppages may be removed from the traps and the horizontal portions of fixture drains.

2. If a trap is not accessible for removal or does not contain a removable dip, a cleanout or a removable inlet shall be installed to enable cleaning of the trap passageway and the horizontal portions of the fixture drain.

(k) *Conductors.* Where a cleanout is provided in a conductor, the cleanout shall be located 28 to 60" above the lowest floor penetrated by the conductor.

(L) *Sampling manholes.* Municipalities or sanitary sewage districts by ordinance or rule may require the installation of sampling manholes for periodic sewage monitoring.

Note: The installation of sampling manholes may be needed for the monitoring of industrial wastes under chs. NR 200 to 299. See Appendix for further explanatory material.

(m) *Catch basins and interceptors.* The fixture drain from all interceptors designed in accordance with s. Comm 82.34 (4) (a) 2. shall be provided with an accessible cleanout located outside of the basin and not more than 15 inches from the weir of the trap.

(4) **DIRECTION OF FLOW.** Every cleanout shall be installed so as to open in the direction of the waste flow or at a right angle thereto.

(5) **ACCESSIBILITY.** Cleanout plugs shall not be covered with cement, plaster, or any other similar permanent finishing material.

(a) *Underground piping.* Cleanouts installed in underground drain piping shall be extended vertically to or above the finish grade.

1. All interior and exterior cleanouts where the vertical distance between the centerline of the horizontal drain pipe being served and the top of the cleanout opening exceeds 18" in length, shall connect to the drain piping through a fitting as specified in Table 82.30-4.

2. A cleanout located outside of a building shall be provided with a frost sleeve.

a. The frost sleeve shall be of a material approved for building sewers in accordance with s. Comm 84.30 (2) (c).

b. Where a cleanout is located in an area subject to vehicular traffic the top of the frost sleeve shall terminate in a concrete pad at least 4" thick and extending at least 9" from the sleeve on all sides, sloping away from the sleeve.

c. The bottom of the frost sleeve shall terminate 6" to 12" above the top of the drain piping or at least 6" below the predicted frost depth in accordance with s. Comm 82.30 Table 82.30-6.

d. The frost sleeve shall have a removable watertight top of sufficient thickness and strength to sustain the weight of anticipated traffic.

Note: See Appendix for further explanatory material.

(b) *Concealed piping.* Cleanout access for drain piping located in concealed spaces shall be provided by either extending the cleanout to at least the surface of a wall or floor or by providing

access panels of a sufficient size to permit removal of the cleanout plug and proper cleaning of the pipe.

(6) **CLEANOUT SIZE.** Cleanouts and cleanout extensions shall be sized in accordance with Table 82.35.

(7) **PROHIBITED USE OF CLEANOUT OPENINGS.** Cleanout openings shall not be used for the installation of fixtures or floor drains, except where another cleanout of equal access and capacity is provided.

(8) **MANHOLES.** (a) *Diameter.* The minimum diameter of manholes shall be 42". A manhole shall have a minimum access opening of 24".

(b) *Materials.* Manholes shall be constructed of approved materials in accordance with ch. Comm 84 and in accordance with the design provisions of s. NR 110.13.

**Note:** The provisions of s. NR 110.13 regarding the manhole's flow channel, watertightness, and drop pipe indicate the following specifications:

—The flow channel through manholes shall be made to conform to the shape and slope of the sewer.

—Solid watertight manhole covers are to be used wherever the manhole tops may be flooded by street runoff or high water. Where groundwater conditions are unfavorable, manholes of brick or block shall be waterproofed on the exterior with plastic coatings supplemented by a bituminous waterproof coating or other approved coatings. Inlet and outlet pipes are to be joined to the manhole with a gasketed flexible watertight connection or any watertight connection arrangement that allows differential settlement of the pipe and manhole wall to take place.

—An outside drop pipe is to be provided for a sewer entering a manhole where the invert elevation of the entering sewer is 2 feet or more above the spring line of the outgoing sewer. The entire drop connection shall be encased in the concrete. Inside drop connection may be approved on a case-by-case basis.

**Note:** See Appendix for further explanatory material.

**Table 82.35**  
**CLEANOUT SIZES**

Diameter of Pipe Served by Cleanout (inches)	Minimum Diameter of Cleanout Extension (inches)	Minimum Diameter of Cleanout Opening (inches)
1½	1½	1½
2	1½	1½
3	3	2½
4	4	3½
5	5	4
6	6	5
8 and larger	6	6

**History:** Cr. Register, February, 1985, No. 350, eff. 3-1-85; am. (3) (i), r. and rec. (3) (j), Register, May, 1988, No. 389, eff. 6-1-88; am. (5) (a) 2. a., Register, August, 1991, No. 428, eff. 9-1-91; r. and rec. (3) (j) and (5) (a) 2. c., Register, February, 1994, No. 458, eff. 3-1-94; CR 02-002: am. (3) (a) and (d) 1. (intro.), renum. (3) (g) to be (3) (g) 1. and am., cr. (3) (g) 2. and (m), r. and rec. (5) (a) 1. Register April 2003 No. 568, eff. 5-1-03.

### Comm 82.36 Storm and clear water drain systems.

(1) **SCOPE.** The provisions of this section set forth the requirements for the design and installation of storm and clear water drain systems including storm building drains and sewers.

(2) **MATERIALS.** All storm and clear water drain systems shall be constructed of approved materials in accordance with ch. Comm 84.

(3) **DISCHARGE.** When discharged to a plumbing system, storm water, groundwater and clear water shall be discharged as specified in Table 82.38-1 and in accordance with all of the following conditions:

(a) *Discharge to sanitary sewer.* Clear water may be discharged to a sanitary drain system which connects to a publicly-owned treatment works, if the clear water discharge from the building is not more than 50 gallons per day.

(b) *Segregation of wastewater.* 1. a. Except as provided in subd. 1. b., where a sanitary drain system and a storm drain system are available, the piping carrying storm water, groundwater or clear water may not connect to any part of the sanitary drain system.

b. Where a combined sanitary-storm sewer system is available, storm water, groundwater, clear water and sanitary wastewater may not be combined prior to discharging to the building sewer.

2. When discharged by gravity, storm water may not be combined with clear water prior to discharging to the storm building drain.

(4) **LOAD ON DRAIN PIPING.** (a) *Storm water drainage.* The load factor on storm water drain piping shall be computed in terms of gallons per minute or on the square footage of the horizontal projection of roofs, paved areas, yards and other tributary areas based on a minimum of 3.7" per hour and the surface area to gallons per minute (gpm) conversion factors in Tables 82.36-1 to 82.36-3.

(b) *Continuous flow devices.* Where there is a continuous or semicontinuous discharge into the storm building drain or storm building sewer, as from a pump, air conditioning unit, or similar device, each gallon per minute of such discharge shall be computed as being equivalent to 26 square feet of roof area.

(5) **SELECTING SIZE OF STORM AND CLEAR WATER DRAIN PIPING.** (a) *Horizontal storm water drain piping.* The pipe size for horizontal drain piping for storm water shall be determined from Tables 82.36-1 to 82.36-4a, or a detailed engineering analysis acceptable to the department.

(b) *Vertical conductors for storm water.* 1. A vertical conductor for storm water shall not be smaller than the largest horizontal branch connected thereto.

2. Vertical conductors shall be sized in accordance with Table 82.36-5 or the diameter D, where

$$D = 1.128 \sqrt{\frac{A}{X}}$$

where, A = the area of the roof in square feet

X = 300 square feet per square inch for a roof covered with gravel or slag and with a pitch not exceeding ¼ inch per foot; or

= 250 square feet per square inch for a roof covered with gravel or slag and with a pitch of greater than ¼ inch per foot; or

= 200 square feet per square inch for a roof with a metal, tile, brick or slate covering and of any pitch.

(c) *Clear water drain piping.* Drain piping for clear water shall be sized in accordance with s. Comm 82.30 (3) and (4).

**Table 82.36-1**  
**MINIMUM SIZE OF STORM WATER HORIZONTAL DRAIN PIPING SERVING ROOF AREAS**

Pipe Diameters (in inches)	Maximum Roof Areas (in square feet)			
	Pitch of Piping Per Foot			
	1/16 inch	1/8 inch	1/4 inch	1/2 inch
3	650	910	1,300	1,820
4	1,300	1,950	2,990	3,770
5	2,470	3,640	5,070	7,020
6	4,160	5,980	8,320	11,700
8	9,320	13,000	18,200	26,000
10	17,680	24,700	33,800	50,440
12	27,300	41,080	57,200	81,900
15	52,000	72,800	105,300	146,640
18	85,800	121,550	174,200	247,000
21	156,520	179,660	256,880	374,400
24	187,200	261,560	382,200	546,000

Note: Divide square footage by 26 to obtain flow in gpm.

**Table 82.36-2**  
**MINIMUM SIZE OF STORM WATER HORIZONTAL DRAIN PIPING SERVING PAVED OR GRAVELED GROUND SURFACE AREAS**

Pipe Diameters (in inches)	Maximum Surface Areas (in square feet)			
	Pitch of Piping Per Foot			
	1/16 inch	1/8 inch	1/4 inch	1/2 inch
3	810	1,140	1,625	2,270
4	1,625	2,430	3,740	4,720
5	3,090	4,550	6,350	8,760
6	5,200	7,470	10,400	14,600
8	11,650	16,250	22,750	32,600
10	22,100	30,850	44,250	63,000
12	34,150	52,300	71,500	102,200
15	65,000	91,000	131,500	183,000
18	107,000	152,000	210,800	321,000
21	195,000	224,000	321,000	468,000
24	234,000	336,000	478,000	682,000

Note: Divide square footage by 32.5 to obtain flow in gpm.

(d) *Minimum size of underground drain piping.* Any portion of a storm or clear water drain system installed underground shall not be less than 2" in diameter. Underground drain piping which is 2" in diameter shall not exceed a length of 20 feet.

(e) *Minimum size of storm building sewers.* The pipe size for storm building sewers shall be determined from Tables 82.36-1 to 82.36-4a. Storm building sewers transporting combined storm water, groundwater or clear water shall be sized in accordance with Tables 82.36-4 and 82.36-4a.

1. Gravity flow sewers. a. The minimum size of a gravity flow storm building sewer shall be 3" in diameter between the

building and lot line and 4" in diameter between the lot line and public sewer or private interceptor main sewer. A municipality or sanitary district by ordinance may require that portion of the storm building sewer between the lot line and public sewer or private interceptor sewer to be larger than 4" in diameter.

b. A gravity flow storm building sewer shall not be smaller than any storm building drain connected thereto, except a decrease in diameter in the direction of flow will be permitted if the increase in slope is sufficient to maintain the volume rate of flow. A reduction in diameter for the storm building sewer shall be made in a manhole.

2. Pressurized or forced sewers. Pressurized storm building sewers shall be not less than 1 1/4" in diameter.

**Table 82.36-3**  
**MINIMUM SIZE OF STORM WATER HORIZONTAL DRAIN PIPING SERVING LAWNS, PARKS AND SIMILAR LAND SURFACES**

Pipe Diameters (in inches)	Maximum Surface Areas (in square feet)			
	Pitch of Piping Per Foot			
	1/16 inch	1/8 inch	1/4 inch	1/2 inch
3	2,600	3,640	5,200	7,280
4	5,200	7,800	11,960	15,080
5	9,880	13,560	20,280	28,080
6	16,640	23,920	33,280	46,800
8	37,280	52,000	72,800	112,000
10	69,720	98,800	135,200	201,760
12	109,200	164,320	228,800	327,600
15	208,000	291,200	421,200	586,560
18	343,200	490,200	596,800	988,000
21	626,080	718,640	1,027,520	1,497,600
24	748,800	1,046,240	1,528,800	2,184,000

Note: Divide square footage by 104 to obtain flow in gpm.

**Table 82.36-4**  
**MAXIMUM CAPACITY OF STORM WATER HORIZONTAL DRAIN PIPING FLOWING FULL**

Pipe Diameters (in inches)	Maximum Capacities (in gallons per minute)			
	Pitch of Piping Per Foot			
	1/16 inch	1/8 inch	1/4 inch	1/2 inch
3	25	35	50	70
4	50	75	115	145
5	97	140	195	270
6	160	230	320	450
8	355	500	700	1,000
10	680	950	1,300	1,940
12	1,050	1,580	2,200	3,150
15	2,000	2,800	4,050	5,640
18	3,300	4,675	6,700	9,500
21	6,020	6,910	9,880	14,400
24	7,200	10,060	14,700	21,000



**Table 82.36-4a**  
**MAXIMUM CAPACITY OF STORM WATER**  
**HORIZONTAL DRAIN PIPING FLOWING FULL**  
**FOR ELLIPTICAL REINFORCED CONCRETE PIPE**

Pipe Diameters in inches (circular pipe equivalent)	Maximum Capacities (in gallons per minute)			
	Pitch of Piping Per Foot			
	1/16 inch	1/8 inch	1/4 inch	1/2 inch
14 X 23 (18)	3,300	4,675	6,700	9,500
19 X 30 (24)	7,200	10,060	14,700	21,000
24 X 38 (30)	13,250	18,740	26,500	37,475
29 X 45 (36)	21,545	30,475	43,095	60,940
34 X 53 (42)	32,500	45,965	65,000	91,925
38 X 60 (48)	46,405	65,625	92,800	131,245
43 X 68 (54)	63,525	89,840	127,050	179,800
48 X 76 (60)	84,135	118,985	168,270	237,965

**(6) PITCH OF HORIZONTAL DRAIN PIPING.** All horizontal drain piping shall be installed at a pitch which will produce a computed velocity of at least one foot per second when flowing full.

**(a) Storm water drain piping.** The minimum pitch of horizontal drain piping shall be in accordance with Tables 82.36-1 to 82.36-4a, or as otherwise approved by the department.

**(b) Clear water drain piping.** The minimum pitch of horizontal clear water drain piping less than 3" in diameter shall be 1/8" per foot. The minimum pitch of horizontal drain piping 3" or larger in diameter shall be 1/16" per foot.

**(7) CHANGES IN DIRECTION OF FLOW.** Changes in direction of flow for storm and clear water drain piping shall be in accordance with s. Comm 82.30 (8).

**(8) DRAINAGE FITTINGS AND CONNECTIONS.** Drain piping fittings and connections shall be in accordance with s. Comm 82.30 (9).

**(9) STACK OFFSETS.** Stack offsets in clear water drain piping shall comply with s. Comm 82.30 (6).

**(10) FIXTURE BRANCH CONNECTIONS NEAR BASE OF STACK.** Branch drains from interior clear water inlets shall not connect downstream from the base fitting or fittings of a drain stack or conductor within the distance equal to 20 pipe diameters of the building drain.

**(11) SUMPS AND PUMPS.** **(a) Sumps.** 1. General. All storm building subdrains shall discharge into a sump, the contents of

which shall be automatically lifted and discharged into the storm drain system.

2. Construction and installation. a. Except as specified in subd. 2. b., the sump shall have a rim extending at least one inch above the floor immediately adjacent to the sump. The sump shall have a removable cover of sufficient strength for anticipated loads. The sump shall have a solid bottom.

b. Where the sump is installed in an exterior meter pit or elevator pit, the rim shall be level with the floor.

3. Location. All sumps installed for the purpose of receiving clear water, or basement or foundation drainage water shall be separated from any reservoir or water well by the applicable separation distances contained in chs. NR 811 and 812 or as otherwise approved by the department of natural resources.

**Note:** See Appendix A-82.30 (11) (d) for material reprinted from s. NR 812.08. Section NR 812.08 may have additional setback requirements.

4. Size. The size of each clear water sump shall be as recommended by the sump pump manufacturer, but may not be smaller than 16" in diameter at the top, 14" in diameter at the bottom, and 22" in depth.

5. Removable covers. a. Except as specified in subd. 5. b., penetrations through the top of removable sump covers shall be limited to those for the electrical supply, the vent piping and the discharge piping for the pump or pumps.

b. A sump installed in an exterior meter pit or an elevator pit may be provided with an open grate cover.

**Note:** In accordance with s. Comm 18.21, a sump may not be located in an elevator machine room.

**(b) Sump pump systems.** 1. Pump size. The pump shall have a capacity appropriate for anticipated use.

2. Discharge piping. Where a sump discharges into a storm building drain or sewer, a free flow check valve shall be installed.

**(12) SUBSOIL DRAINS.** Where a foundation drain is subject to backwater, it shall be protected by an accessible backwater valve or a sump with pump.

**(13) STORM BUILDING DRAINS AND SEWERS.** **(a) Limitations.** No storm building sewer or private interceptor main storm sewer may pass through or under a building to serve another building, unless:

1. The storm building sewer or private interceptor main storm sewer serves farm buildings or farm houses or both which are all located on one property; or

2. The storm building sewer or private interceptor main storm sewer serves buildings which are all located on one property and a document, which indicates the piping and distribution arrangement for the property and buildings, will be recorded with the register of deeds no later than 90 days after installation.

**Table 82.36-5**  
**MINIMUM DIAMETER OF VERTICAL CONDUCTORS**

Type of Roof	Maximum Roof Areas (in square feet)					
	Pipe Diameters (in inches)					
	2 1/2	3	4	5	6	8
Roofs covered with gravel, slag, or similar material and with a pitch of 1/4" per foot or less.	1,645	2,120	3,780	5,885	8,490	15,125
Roofs covered with gravel, slag or similar material and with a pitch greater than 1/4" per foot.	1,220	1,770	3,150	4,905	7,075	12,600
Roofs covered with metal, tile, brick, slate or similar material and of any pitch.	975	1,415	2,520	3,925	5,660	10,080

**Note:** Divide square footage by 26 to obtain flow in gpm.

**(b) Extensions to grade.** 1. The connection of a storm water leader discharging to a storm building sewer shall be made above the finished grade.

2. The diameter of the drain piping connecting a storm water leader to a storm building drain or sewer shall be in accordance with sub. (5).

(c) *Other requirements.* 1. Elevation. The elevation of storm building drains shall comply with s. Comm 82.30 (11) (b) 1.

2. Backflow protection. Storm building drains subject to backflow or backwater shall be protected in accordance with s. Comm 82.30 (11) (b) 2.

3. The location of storm building drains and building sewers shall be in accordance with s. Comm 82.30 (11) (d).

4. Storm building drains and building sewers shall be installed in accordance with s. Comm 82.30 (11) (e).

5. Storm building sewers shall be connected to main sewers in accordance with s. Comm 82.30 (11) (f).

**(14) TRAP REQUIREMENTS.** (a) Traps shall be required for interior drain inlets receiving clear water.

(b) Except for exterior loading dock drains, traps shall be required for exterior drain inlets located within 10 feet of an air inlet, door or openable window. Where a trap is required, the trap may be located inside the building. More than one drain inlet may discharge to the same trap.

*Note:* Traps may be located inside the building.

(c) Where a foundation drain discharges by gravity to a storm sewer the drain shall be trapped. Such a trap shall be provided with a cleanout.

**(15) VENTS.** (a) Except as provided in par. (b), a trap located inside a building shall be vented in accordance with s. Comm 82.31. Vent piping for clear water or stormwater systems shall not connect to other venting systems.

(b) Vents shall not be required for traps which receive only storm water or groundwater.

**(16) INTERIOR DRAIN INLETS.** Interior clear water drain inlets shall terminate at least one inch above the finished floor.

**(17) AREA DRAIN INLETS.** (a) *Drain inlet design and construction.* 1. General. Storm water area drain inlets shall be constructed in a watertight and substantial manner of approved materials in accordance with ch. Comm 84.

2. Inlet base. All site-constructed storm water area drain inlets subject to vehicular traffic shall be set on a 6" thick air-entrained concrete base with a minimum estimated compressive strength at 28 days of 3000 psi or on an approved precast concrete base.

3. Size. The size of masonry or concrete inlet basins shall be in accordance with subd. 3. a. and b.

a. Inlet basins 36" or less in depth shall have a minimum inside diameter of 24". Basins shall be provided with an open bar grate not less than 18" in diameter.

b. Inlet basins with a depth greater than 36" shall have a minimum inside diameter of 36". Basins shall be provided with an open bar grate not less than 24" in diameter.

4. Inlet grates. All inlets shall have an approved, well fitted, removable cast iron or steel grate of a thickness and strength to sustain anticipated loads. The grate shall have an available inlet area equal to or greater than the required waste outlet of the inlet.

*Note:* See Appendix for further explanatory material.

(b) *Subsurface areas of 50 square feet or less.* All subsurface areas, exposed to the weather, other than stairwells, with areas not exceeding 50 square feet shall be drained. These areas may drain to subsoil drains through a minimum 2 inch diameter pipe or a continuous layer of gravel or may drain to the storm building drain, storm subdrain, or storm sewer through a minimum 3 inch diameter pipe.

(c) *Subsurface areas of more than 50 square feet and stairwells.* An area drain shall be provided in subsurface areas, greater than 50 square feet in area, and all stairwells which are exposed to the weather. These areas shall be drained to the storm building drain, storm subdrain or storm sewer. If no storm sewer exists, the discharge shall be in accordance with sub. (3) (b). The fixture drain shall have a minimum inside diameter of 3" and shall not discharge into a subsoil, footing or foundation drain.

**(18) ROOF DRAINS.** (a) *General roofs.* Roof drains shall be equipped with strainers extending not less than 4" above the surface of the roof immediately adjacent to the roof drain. Strainers shall have an available inlet area above the roof of not less than 1-1/2 times the area of the conductor to which the drain connects.

(b) *Flat decks.* Roof drain strainers for use on sun decks, parking decks and similar areas may be of the flat surface type level with the deck, and shall have an available inlet area of not less than twice the area of the conductor to which the drain connects.

**(19) CONTROLLED FLOW ROOF DRAIN SYSTEMS.** (a) *Application.* In lieu of sizing the roof storm drain piping on the basis of actual maximum horizontal projected roof areas as specified in sub. (4), the roof drain piping may be sized based on the equivalent adjusted maximum horizontal projected roof areas which result from controlled flow and storage of storm water on the roof.

*Note:* See chs. Comm 61 to 65 as to provisions relating to the structural design of the roof for controlled flow drain systems.

(b) *Installation.* Control of storm water runoff shall be by control devices. Control devices shall be protected by strainers.

(c) *Sizing.* Not less than 2 drains shall be installed in roof areas 10,000 square feet or less and at least 4 drains in roofs over 10,000 square feet in area.

*History:* Cr Register, February, 1985, No. 350, eff. 3-1-85; r. and recr. (3) (a) and (b) 1., (c) 1. and (11) (a) 4., cr. (3) (c) 3., Register, May, 1988, No. 389, eff. 6-1-88; renum. (13) (a) and (b) to be (b) and (c) and am. (b) 1., cr. (3) (b) 3. and (13) (a), r. (3) (c) 3. and (13) (intro.), Register, August, 1991, No. 428, eff. 9-1-91; reprinted to correct error in (5) (e) 2., Register, October, 1991, No. 430; am. (3) (b) 1., (c) 1. a., (13) (b) 1. and (c), cr. (11) (a) 5., Register, February, 1994, No. 458, eff. 3-1-94; r. and recr. (11) (a) 2. and 5., Register, April, 1998, No. 508, eff. 5-1-98; renum. and am. (3) (b) 3. a. to be (3) (b) 3. and (3) (b) 3. b. to be (3) (b) 4., Register, April, 2000, No. 532, eff. 7-1-00; am. (3) (b) 3., (4) (a), (5) (a) and (6) (a), cr. (3) (b) 5. and Table 82.36-4a, Register, December, 2000, No. 540, eff. 1-1-01; CR 02-002: r. and recr. (3), (11) (a) 3., (13) (a) 2., (15) (a) and (b), am. (5) (e) (intro.), (10), (12), (14) and Table 82.36-4 Register April 2003 No. 568, eff. 5-1-03.

**Comm 82.37 Sanitation facilities and camp grounds.** **(1) COMPOSTING SYSTEMS.** (a) Composting systems which employ water or other liquids as a transport medium for wastes shall conform with this subsection.

*Note:* Composting systems where water or other liquids are not employed as a transport medium are addressed under ch. Comm 91.

(b) The materials, design, construction and performance of a composting system which employs water or other liquids as a transport medium for wastes shall conform to NSF Standard 41.

(c) All composting systems shall be listed by a testing agency acceptable to the department.

*Note:* Listing agencies acceptable to the department include the American Gas Association; Canadian Standards Association; NSF International; Underwriter's Laboratories; and Warnock Hersey.

(d) 1. Components for the storage or treatment of wastes shall be continuously ventilated.

2. Ventilation ducts or vents for the composting system shall conform to s. Comm 82.31 (16).

(e) 1. The disposal of the end product from a composting system shall be in accordance with 40 CFR Part 503, Standards for the Use or Disposal of Sewage Sludge.

*Note:* EPA materials relating to EPA 503, including, "Domestic Septage Regulatory Guidance: A Guide to the EPA 503 Rule", are available from the Office of Water Resource, US EPA, 401 M Street SW, Washington D.C. 20460.

2. The disposal of any liquid from a composting system shall be either to a publicly owned treatment works or a POWTS conforming to ch. Comm 83.

(f) The connection of potable water supplies to a composting system shall be protected in accordance with s. Comm 82.41.

(g) The drainage systems for the composting system shall conform to the applicable requirements of ss. Comm 82.30 to 82.36 and the manufacturer's specifications.

**(2) SANITARY DUMP STATIONS.** (a) Sanitary dump stations which are used to receive domestic wastes and domestic wastewater from the holding tanks of travel trailers, recreational vehicles or other similar mobile vehicles, and transfer containers shall conform with this subsection.

(b) The drain receptor for a sanitary dump station shall be at least 4" in diameter.

(c) 1. The drain receptor shall be provided with a self-closing cover.

2. The cover for the drain receptor shall be operable without touching the cover with one's hands.

(d) The drain receptor shall be surrounded by an impervious pad at least 6 feet in diameter. The pad shall be:

1. Pitched toward the drain receptor with a minimum slope of 1/4" per foot; and

2. Of sufficient strength to sustain anticipated loads.

(e) The drain receptor shall be trapped in accordance with s. Comm 82.32.

(f) The drain receptor for a sanitary dump station that is installed within an enclosed structure shall be vented in accordance with s. Comm 82.31.

(g) A supply of water shall be provided to wash down the drain receptor and pad. The water supply shall be:

1. Provided with cross connection control in accordance with s. Comm 82.41; and

2. Labeled indicating that the supply is not for drinking purposes.

(h) 1. Aboveground drains shall be constructed of approved materials in accordance with s. Comm 84.30 (2) (a).

2. Aboveground water supply piping shall be constructed of approved materials in accordance with s. Comm 84.30 (4) (e).

**(3) CAMPGROUNDS.** (a) *Drain systems.* Sewers serving campgrounds shall comply with the provisions in s. Comm 82.30 and all of the following:

1. A drain line serving a recreational vehicle shall discharge to a minimum 4-inch diameter campsite receptor by means of an indirect waste pipe.

2. One campsite receptor shall be designed to serve no more than 4 recreational vehicles.

3. Where 2 or more drain lines are designed to discharge into the same campsite receptor, an increaser shall be installed in the vertical portion of the trap riser to accommodate the drains.

4. The rim of a campsite receptor shall terminate no less than 4 inches above the finished grade.

5. The rim of a campsite receptor shall not terminate at an elevation that is higher than the water supply termination serving the same site.

6. A vent is not required to serve the trap serving a campsite receptor.

7. When not in use, a campsite receptor shall be capped.

(b) *Water supply systems.* Water supply systems serving campgrounds shall comply with the provisions in s. Comm 82.40 and all of the following:

1. An accessible control valve shall be installed at the most upstream point of the campground water supply distribution system and downstream of the municipal meter or pressure tank.

2. If water is provided to a campsite, individual approved backflow protection shall serve each hose connection in accordance with s. Comm 82.41.

3. A campsite water supply riser shall terminate no less than 12" above finished grade.

**Note:** See Appendix A-82.37 (3) for further explanatory material.  
**History:** Cr. Register, April, 2000, No. 532, eff. 7-1-00; CR 02-002: cr. (2) (h) and (3) Register April 2003 No. 568, eff. 5-1-03.

**Comm 82.38 Discharge points. (1) PURPOSE.** The purpose of this section is to establish allowable discharge points for wastewater discharging from plumbing systems.

**(2) SCOPE.** The provisions of this section set forth the requirements for the discharge points for wastewater based on the use of the fixtures, appurtenances, appliances and devices discharging into the plumbing system.

**(3) GENERAL REQUIREMENTS.** (a) Wastewater from plumbing systems shall be discharged as specified in Table 82.38-1.

(b) Wastewater from uses other than those listed in Table 82.38-1, shall be discharged as specified by the department on a site-specific basis.

Table 82.38 – 1  
ALLOWABLE DISCHARGE POINTS BY FIXTURE OR SPECIFIC USES

Use or Fixture	Allowable Discharge Points					
	POWTS <sup>a</sup>	Municipal Sanitary Sewer	Municipal Storm Sewer	Ground Surface	Combined Sanitary-Storm Sewer	Subsurface Dispersal
1. Cross connection control device or assembly [see s. Comm 82.33 (9) (i)]	X	X		X <sup>b, c, e</sup>	X	
2. Domestic wastewater	X	X			X	
3. Condensate from high efficiency furnace or water heater	X	X			X	
4. Drinking fountain	X	X	X	X <sup>b</sup>	X	X <sup>d</sup>
5. Elevator pit drain [see s. Comm 82.33 (9) (f)]			X	X <sup>b</sup>	X	X <sup>d</sup>
6. Enclosed public parking levels	X	X		X <sup>b</sup>	X	X <sup>d</sup>
7. Industrial wastewater <sup>h</sup>	X <sup>f</sup>	X			X	
8. Municipal well pump house floor drain and sink	X	X		X <sup>b</sup>	X	X <sup>d</sup>
9. One- and 2-family garage floor area [see s. Comm 82.34 (4) (b)]	X	X		X <sup>b</sup>	X	
10. Storm water, groundwater and clear water	X	X <sup>g</sup>	X <sup>c</sup>	X <sup>b</sup>	X	X <sup>d</sup>
11. Swimming pool or wading pool-- diatomaceous earth filter backwash	X	X			X	
12. Swimming pool or wading pool-- drain wastewater	X	X <sup>b</sup>	X <sup>b, c</sup>	X <sup>b, c</sup>	X <sup>b</sup>	X <sup>d</sup>
13. Swimming pool or wading pool-- sand filter backwash	X	X <sup>b</sup>	X <sup>b, c</sup>	X <sup>b, c</sup>	X <sup>b</sup>	X <sup>d</sup>
14. Water heater temperature and pressure relief valve [see s. Comm 82.40 (5)]	X	X	X	X <sup>b</sup>	X	X <sup>d</sup>
15. Wastewater from water treatment device	X	X	X <sup>c</sup>	X <sup>b, c</sup>	X	X <sup>d</sup>
16. Whirlpool backwash drain and wastewater	X	X	X <sup>c</sup>	X <sup>b, c</sup>	X	
17. Discharges not specifically listed above				Contact the department		

<sup>a</sup> Allowed when the POWTS is designed to include designated wastewater.

<sup>b</sup> Unless prohibited by local municipality and when no nuisance is created.

<sup>c</sup> A discharge permit may be required by the department of natural resources.

<sup>d</sup> For public buildings or facilities, allowed after receiving plan approval from the department. See also s. Comm 82:20.

<sup>e</sup> Allowed for exterior installation and when no sanitary sewer is in the building.

<sup>f</sup> Refer to the department of natural resources for discharge regulations.

<sup>g</sup> Fifty gpd clear water as specified under s. Comm 82.36 (3) (b).

<sup>h</sup> The department of natural resources may require WPDES permits for industrial discharges and may allow other options.

History: CR 02-002: cr. Register April 2003 No. 568, eff. 5-1-03; CR 02-129: am. Table 82.38-1 line 15 Register January 2004 No. 577, eff. 2-1-04.

#### Subchapter IV — Water Supply Systems

**Comm 82.40 Water supply systems. (1) SCOPE.** The provisions of this section set forth the requirements for the design and installation of water supply systems.

Note: Chapter NR 811 governs the design and construction of community water systems or waterworks.

**(2) MATERIALS.** All water supply systems shall be constructed of approved materials in accordance with ch. Comm 84.

**(3) GENERAL. (a) Potable water required.** 1. Every outlet providing water shall be provided with water of the quality as specified under s. Comm 82.70 (3) for the intended use.

2. Nonpotable water may be supplied to water treatment devices or systems designed to treat water for compliance with Table 82.70-1.

(b) *Hot water required.* Except as provided in subds. 1. and 2., hot water shall be provided to all plumbing fixtures, appliances and equipment used for personal washing, culinary purposes or laundering.

1. Tempered water. a. Tempered water or hot water shall be provided to lavatories, wash fountains and shower heads which are not located in dwelling units or living units.

b. Tempered water supplied to serve multiple lavatories, wash fountains and shower heads shall be provided by means of thermostatic mixing valves.

2. Lavatories located in park shelters and bath houses which are not open during the period from November 15 to March 15 and which are not places of employment shall not be required to be provided with hot water.

3. Lavatories located in waysides which are not places of employment shall not be required to be provided with hot water.

*Note:* The exception of providing hot water under subds. 1. to 3. does not supercede the requirements of other state agencies for providing hot water.

(c) *Protection.* 1. Pursuant to s. NR 811.09 (2) the interconnection of 2 or more water supply systems, one system served by a public supply source and the other system served by another supply source is prohibited, unless approved in writing by the department of natural resources.

2. A water supply system shall be designed and installed in accordance with s. Comm 82.41 and maintained to prevent non-potable liquids, solids or gases from being introduced into the potable water supply system through cross connections.

3. a. Except as provided in subd. 3. b., when a connection between 2 water supply systems exists, one system having a higher degree of hazard than the other system as specified in s. Comm 82.41, the water supply system with a lower degree of hazard shall be protected as specified in s. Comm 82.41.

b. When a water treatment device is provided to lower the concentration of a health-related contaminant, cross connection control shall not be required to protect the water supply system downstream of the treatment device from the upstream contaminated source.

(d) *Identification.* 1. Where buildings or facilities contain water supply systems where the water supply systems have different degrees of hazard, all water supply systems shall be labeled in accordance with this section.

a. All aboveground piping supplying nonpotable water shall be labeled by tags or yellow bands. The yellow bands shall be at least 3 inches wide and shall bear text identifying the water and the specific use or uses.

b. The tags or colored bands shall be placed at intervals of not more than 25 feet. Where piping passes through a wall, the piping shall be so identified on each side of the wall and within each compartment.

c. The tags or colored bands identifying nonpotable water and potable water piping shall be placed at intervals of not more than 25 feet and at each side where the piping passes through a wall, floor or roof.

d. All valves and outlets supplying nonpotable water shall be identified nonpotable by tags.

e. All valves, except fixture stop valves, supplying potable water shall be identified potable by tags.

f. Tags used to identify nonpotable water outlets, valves and piping shall be of metal or plastic in the shape of an equilateral triangle with 4 inch sides and bearing the legend "water unsafe" or other similar wording approved in writing by the department. The lettering on the tags shall be raised or indented and at least 1/2" in height.

g. Tags used to identify potable water valves shall be of metal or plastic in the shape of a 3-inch diameter circle bearing the legend "safe water" or other similar wording approved in writing by the department. The lettering on the tags shall be raised or indented and at least 1/2" in height.

h. A hose bibb intended to discharge water that does not meet drinking water quality as specified in s. Comm 82.70, shall be labeled as nonpotable or so identified for the specific use or uses, and shall be equipped with a removable key handle.

2. Where a building or a structure is served by 2 distribution systems, one system supplied by a public water supply and the other system supplied by a private well, each water distribution system shall be identified to indicate the supply source.

3. The installation of each reduced pressure principle backflow preventer, reduced pressure detector backflow preventer, pressure vacuum breaker assembly, and back siphonage backflow vacuum breaker shall display a department assigned identification number. The provisions of this subdivision shall take effect September 1, 2001.

a. The method to display the department assigned identification number shall be a weather-resistant tag, securely attached to the cross connection control assembly.

b. The tag shall contain at least the following information.

<p style="text-align: center;">Wisconsin Department of Commerce          Identification/Object Number _____          Cross Connection Control Assembly          Do Not Remove This Tag</p>
--

c. The department assigned identification number shall be printed in the blank area with a permanent, waterproof marker or similar indelible method.

*Note:* To obtain a department assigned identification number for a cross connection control assembly contact the department at the Safety and Buildings Division; P.O. Box 7302; Madison, Wisconsin 53707-7302; telephone (608) 266-0521; Fax (608) 267-0592; TTY (608) 264-8777.

(e) *Multipurpose piping system.* 1. Except as provided in subd. 2., a multipurpose piping system shall be designed and installed in accordance with this section and NFPA 13D.

*Note:* Pursuant to this subdivision and sub. (2), materials for multipurpose piping systems need to be acceptable under the NFPA 13D standard and s. Comm 84.30 Table 84.30-9.

2. a. Fire department connections are prohibited in a multipurpose piping system.

b. Sections 2-3 (b), 2-3 (d), 3-6, 4-1.4.1, 4-1.4.2, 4-4.2 Exception No. 2 (h), 4-6, 5-3.2, 5-4.3 and 5-5 of NFPA 13D do not apply in Wisconsin.

c. The following wording is substituted for section 5-4.4 of NFPA 13D: The minimum distance between sprinklers shall be 6 feet.

(4) **CONTROL VALVES.** (a) *Private water mains.* Private water mains shall be provided with control valves as specified in this subsection.

1. Corporation cocks. a. If a private water main 2" or less in diameter connects to a public water main, a corporation cock shall be installed at the connection to the public water main.

b. If a private water main 2-1/2" or larger in diameter connects to a public water main, a corporation cock shall be installed not more than 8 feet from the connection to the public water main.

2. Curb stops. a. Except as provided in subd. 2. b., if a private water main connects to public water main, a curb stop shall be installed in the private water main between the corporation cock and the property line.

b. If a private water main 2-1/2" or larger in diameter connects to a public water main, one control valve may serve as the corporation cock and the curb stop. The control valve shall be located not more than 8 feet from the connection to the public water main and shall be accessible for operation.

(b) *Water services.* Water services shall be provided with control valves as specified in this subsection.

1. Corporation cocks. a. If a water service 2" or less in diameter connects to a public water main, a corporation cock shall be installed at the connection to the public water main.

b. If a water service 2-1/2" or larger in diameter connects to a public water main, a corporation cock shall be installed not more than 8 feet from the connection to the public water main.

2. Curb stops. a. Except for water services serving farm buildings and farm houses, a curb stop shall be installed in each water service which connects to a private water main. The curb stop shall be located outside the building served by the water service.

b. Except as provided in subd. 2. c., a curb stop shall be installed in each water service which connects to a public water main. The curb stop shall be located between the corporation cock and the property line.

c. If a water service 2-1/2" or larger in diameter connects to a public water main, one control valve may serve as the corporation cock and the curb stop. The control valve shall be located not more than 8 feet from the connection to a public water main and shall be accessible for operation.

3. Building control valves. If a water service serves a building, a building control valve shall be provided in the water service as specified in this subsection.

a. If the water service connects to a public water supply or to a private water supply which has an external pressure tank, the building control valve shall be installed inside the building and located within 3 feet of developed length from the point where the water service first enters the building. If a water meter is provided, the building control valve shall be located upstream of the water meter.

b. If a private water supply includes an internal pressure tank, the building control valve shall be installed inside the building and located within 3 feet of developed length downstream from the internal pressure tank.

*Note:* See Appendix for further explanatory material.

(c) *Water distribution systems.* 1. Control valves shall be installed in water distribution systems serving public buildings as specified in this subdivision.

a. If a water meter is provided, a control valve shall be installed within 3 feet of developed length downstream from the outlet of the water meter. If bypass piping is provided around a water meter, a control valve shall be installed in the bypass piping.

*Note:* See sub. (8) (d) 3. for the requirements relating to the bypassing of water meters.

b. A control valve shall be installed in the supply piping to each water heater and water treatment device and in the fixture supply to each plumbing fixture, plumbing appliance and piece of equipment. The control valve may be part of the bypass piping or an internal part of a water treatment device. When the valve is an internal part of the water treatment device, the device shall be removable for service.

c. If a hot water circulation system is provided, a control valve shall be installed on both the inlet and outlet piping to the circulation pump. If a hot water circulation system has 2 or more return pipe lines, a balancing control valve shall be installed in each return piping line.

d. The water distribution system for buildings with more than 4 dwelling units or living units shall be provided with control valves in such numbers and at such locations so that the water supplied to all the units within the building can be isolated into groups of 4 or less units.

*Note:* See sub. (8) (g) for the valve requirements for water temperature control.

2. Control valves shall be installed in water distribution systems serving one- and 2-family dwellings as specified in this subdivision.

a. If a water meter is provided, a control valve shall be installed within 3 feet of developed length downstream from the outlet of the water meter. If bypass piping is provided around a water meter, a control valve shall be installed in the bypass piping.

*Note:* See sub. (8) (d) 3. for the requirements relating to the bypassing of water meters.

b. A control valve shall be installed in the supply piping to each water heater and water treatment device and in the fixture supply to each water closet, exterior hose bibb, plumbing appliance and piece of equipment. When the valve is an internal part of the water treatment device, the device shall be removable for service.

c. If a hot water circulation system is provided, a control valve shall be installed on both the inlet and outlet piping to the circulation pump. If a hot water circulation system has 2 or more return pipe lines, a balancing control valve shall be installed in each return piping line.

(5) **HOT WATER SUPPLY SYSTEMS.** (a) *General.* Water heating systems shall be sized to provide sufficient hot water to supply both the daily requirements and hourly peak loads of the building.

(b) *Temperature maintenance.* If the developed length of hot water distribution piping from the source of the hot water supply to a plumbing fixture or appliance exceeds 100 feet, a circulation system or self-regulating electric heating cable shall be provided to maintain the temperature of the hot water within the distribution piping.

1. If a circulation system is used to maintain the temperature, no uncirculated hot water distribution piping may exceed 25 feet in developed length.

2. If a self-regulating electric heating cable is used to maintain the temperature, the cable shall extend to within 25 feet of each fixture or the appliance.

3. Water distribution piping conveying circulated water or served by a self-regulating electric heating cable shall be insulated to limit the heat loss at the external surface of the pipe insulation to a maximum of 25 BTUs per hour per square foot for above ground piping and 35 BTUs per hour per square foot for underground piping. The maximum heat loss shall be determined at a temperature differential, T, equal to the maximum water temperature minus a design ambient temperature no higher than 65° F.

4. Water distribution piping served by self-regulating electric heating cable shall be identified as being electrically traced in accordance with ch. Comm 16.

5. The installation of self-regulating electric heating cable may be subcontracted by a plumber to another trade.

*Note:* See A-82.40 (5) for pipe insulation requirements.

(c) *Water heaters.* All water heaters and safety devices shall be designed and constructed in accordance with s. Comm 84.20 (5) (n).

*Note:* Water heaters are to be installed in accordance with the requirements specified in chs. Comm 61 to 65 and chs. Comm 20 to 25 with respect to energy efficiency, enclosures and venting.

(d) *Safety devices.* Water heaters shall be equipped with safety devices as specified in this paragraph.

1. All pressurized storage-type water heaters and unfired hot water storage tanks shall be equipped with one or more combination temperature and pressure relief valves. The temperature steam rating of a combination temperature and pressure relief valve or valves shall equal or exceed the energy input rating in BTU per hour of the water heater. No shut off valve or other restricting device may be installed between the water heater or storage tank and the combination temperature and pressure relief valve.

*Note:* The temperature steam rating of a combination temperature and pressure relief valve is commonly referred to as the AGA temperature steam rating.

2. All pressurized non-storage type water heaters shall be provided with a pressure relief valve installed at the hot water outlet with no shut off valve between the heater and the relief valve.

3. Temperature and pressure relief valves shall be installed so that the sensing element of the valve extends into the heater or tank and monitors the temperature in the top 6" of the heater or tank.

4. A vacuum relief valve shall be installed in each water heater and hot water storage tank which, when measured from the bottom of the heater or tank, is located more than 20 feet above any faucet or outlet served by the heater or tank.

5. Every relief valve which is designed to discharge water or steam shall be connected to a discharge pipe.

a. The discharge pipe and fittings shall be made of a material acceptable for water distribution piping in accordance with s. Comm 84.30 (4) (e) 1.

b. The discharge pipe and fittings shall have a diameter not less than the diameter of the relief valve outlet.

c. The discharge pipe may not be trapped.

d. No valve may be installed in the discharge pipe.

e. The discharge pipe shall be installed to drain by gravity flow to a floor served by a floor drain or to a receptor in accordance with s. Comm 82.33 (8). The outlet of the discharge pipe shall terminate within 6" over the floor or receptor, but not less than a distance equal to twice the diameter of the outlet pipe. The outlet of the discharge pipe may not be threaded.

f. The discharge pipe for a water heater shall terminate within the same room or enclosure within which the water heater or hot water storage tank is located.

(e) *Controls.* 1. All hot water supply systems shall be equipped with automatic temperature controls capable of adjustments from the lowest to the highest acceptable temperature settings for the intended use.

2. A separate means shall be provided to terminate the energy supplied to each water heater and each hot water circulation system.

(6) **LOAD FACTORS FOR WATER SUPPLY SYSTEMS.** (a) *Intermittent flow fixtures.* The load factor for intermittent flow fixtures on water supply piping shall be computed in terms of water supply fixture units as specified in Tables 82.40-1 and 82.40-2 for the corresponding fixture and use. Water supply fixture units may be converted to gallons per minute in accordance with Table 82.40-3.

**Table 82.40-1**  
**WATER SUPPLY FIXTURE UNITS FOR**  
**NONPUBLIC USE FIXTURES**

Type of Fixture <sup>a</sup>	Water Supply Fixture Units (wsfu)		
	Hot	Cold	Total
Automatic Clothes Washer	1.0	1.0	1.5
Bar Sink	0.5	0.5	1.0
Bathtub, with or without Shower Head	1.5	1.5	2.0
Bidet	1.0	1.0	1.5
Dishwashing Machine	1.0		1.0
Glass Filler		0.5	0.5
Hose Bibb:			
1/2" diameter		3.0	3.0
3/4" diameter		4.0	4.0
Kitchen Sink	1.0	1.0	1.5
Laundry Tray, 1 or 2 Compartment	1.0	1.0	1.5
Lavatory	0.5	0.5	1.0
Mobile Home	--	15	15
Shower, Per Head	1.0	1.0	1.5
Water Closet, Flushometer Type		6.0	6.0
Water Closet, Gravity Type Flush Tank		2.0	2.0
<b>Bathroom Groups:</b>			
Bathtub, Lavatory and Water Closet-FM <sup>b</sup>	2.0	7.5	8.0
Bathtub, Lavatory and Water Closet-FT <sup>c</sup>	2.0	3.5	4.0
Shower Stall, Lavatory and Water Closet-FM	1.5	7.0	7.5
Shower Stall, Lavatory and Water Closet-FT	1.5	3.0	3.5

<sup>a</sup> For fixtures not listed, factors may be assumed by comparing the fixture to a listed fixture which uses water in similar quantities and at similar rates.

<sup>b</sup> FM means flushometer type.

<sup>c</sup> FT means flush tank type.

(b) *Continuous flow devices.* The load factor for equipment which demands a continuous flow of water shall be computed on the basis of anticipated flow rate in terms of gallons per minute.

(7) **SIZING OF WATER SUPPLY PIPING.** The sizing of the water supply system shall be based on the empirical method and limitations outlined in this subsection or on a detailed engineering analysis acceptable to the department.

(a) *Methodology.* The determination of minimum pipe sizes shall take into account the pressure losses which occur throughout the entire water supply system and the flow velocities within the water distribution system. Calculations for sizing a water distribution system shall include:

1. The load factor in water supply fixture units or gallons per minute on the piping;
2. The minimum pressure available from the water main or pressure tank;
3. The pressure loss due to the differences in elevation from the:
  - a. Water main or pressure tank to the building control valve; and
  - b. Building control valve to the controlling plumbing fixture;

**Table 82.40-2**  
**WATER SUPPLY FIXTURE UNITS FOR**  
**PUBLIC USE FIXTURES**

Type of Fixture <sup>a</sup>	Water Supply Fixture Units (wsfu)		
	Hot	Cold	Total
Automatic Clothes Washer, Individual	2.0	2.0	3.0
Automatic Clothes Washer, Large Capacity	b	b	b
Autopsy Table	2.0	2.0	3.0
Bathtub, With or Without Shower Head	2.0	2.0	3.0
Coffeemaker		0.5	0.5
Dishwasher, Commercial	b	b	b
Drink Dispenser		0.5	0.5
Drinking Fountain		0.25	0.25
Glass Filler		0.5	0.5
Health Care Fixtures:			
Clinic sink	2.0	7.0	7.0
Exam/treatment sink	0.5	0.5	1.0
Service sink	2.0	2.0	3.0
Sitz bath	1.5	1.5	2.0
Surgeon washup	1.5	1.5	2.0
Hose Bibb:			
1/2" diameter		3.0	3.0
3/4" diameter		4.0	4.0
Icemaker		0.5	0.5
Lavatory	0.5	0.5	1.0
Shower, Per Head	2.0	2.0	3.0
Sinks:			
Bar and Fountain	1.5	1.5	2.0
Barber and Shampoo	1.5	1.5	2.0
Cup		0.5	0.5
Flushing Rim		7.0	7.0
Kitchen and Food Preparation per faucet	2.0	2.0	3.0
Laboratory	1.0	1.0	1.5
Urinal:			
Syphon Jet		4.0	4.0
Washdown		2.0	2.0
Wall Hydrant, Hot and Cold Mix:			
1/2" diameter	2.0	2.0	3.0
3/4" diameter	3.0	3.0	4.0
Wash Fountain:			
Semicircular	1.5	1.5	2.0
Circular	2.0	2.0	3.0
Water Closet:			
Flushometer		6.5	6.5
Gravity Type Flush Tank		3.0	3.0

<sup>a</sup> For fixtures not listed, factors may be assumed by comparing the fixture to a listed fixture which uses water in similar quantities and at similar rates.  
<sup>b</sup> Load factors in gallons per minute, gpm, based on manufacturer's requirements.

**Table 82.40-3**  
**CONVERSION OF WATER SUPPLY FIXTURE UNITS**  
**TO GALLONS PER MINUTE**

Water Supply Fixture Units	Gallons per Minute	
	Predominately Flushometer Type Water Closets or Syphon Jet Urinals	Predominately Flush Tank Type Water Closets or Washdown Urinals
1	—	1
2	—	2
3	—	3
4	10	4
5	15	4.5
6	18	5
7	21	6
8	24	6.5
9	26	7
10	27	8
20	35	14
30	40	20
40	46	24
50	51	28
60	54	32
70	58	35
80	62	38
90	65	41
100	68	42
120	73	48
140	78	53
160	83	57
180	87	61
200	92	65
250	101	75
300	110	85
400	126	105
500	142	125
600	157	143
700	170	161
800	183	178
900	197	195
1000	208	208
1250	240	240
1500	267	267
1750	294	294
2000	321	321
2250	348	348
2500	375	375
2750	402	402
3000	432	432
4000	525	525
5000	593	593

Note: Values not specified in the table may be calculated by interpolation.



4. The pressure losses due to flow through water heaters, water treatment devices, water meters and backflow preventers;

5. The minimum flow pressure needed at the controlling plumbing fixture; and

6. The pressure losses due to flow friction through piping, fittings, valves and other plumbing appurtenances. This pressure loss may be calculated in terms of equivalent lengths of piping. The equivalent length of piping to a controlling plumbing fixture, including fittings, valves and other appurtenances, may be obtained by multiplying the developed length by 1.5.

Note: See Appendix for further explanatory material.

(b) *Private water mains and water services.* Private water mains and water services shall be designed to supply water to the water distribution systems to maintain the minimum flow pressures specified in par. (d), but shall not be less than 3/4" in diameter.

Note: See Appendix for further explanatory material.

(c) *Maximum loading.* The calculated load on any portion of the water distribution system may not exceed the limits specified in Tables 82.40-4 to 82.40-9.

(d) *Pressure.* 1. Except as provided in subd. 1. a. to c., water supply systems shall be designed to provide at least 8 psig of flow pressure at the outlets of all fixture supplies.

a. The flow pressure at the outlets of the fixture supplies serving siphonic type urinals, washdown type urinals and washdown type water closets, siphonic type flushometer water closets and campsite water supply hose connections shall be at least 15 psig.

b. The flow pressure at the outlets of the fixture supplies serving one piece tank type water closets, pressure balance mixing valves, mobile homes, and thermostatic mixing valves shall be at least 20 psig.

c. The flow pressure at the outlets of the fixture supplies serving blowout type urinals and blowout type water closets shall be at least 25 psig.

2. a. Except as provided in subd. 3., if the water pressure available from a water main or private water supply exceeds 80 psig, a pressure reducing valve and strainer, if a strainer is not a component of the valve, shall be installed in the water distribution system.

b. A pressure reducing valve required under subd. 2. a. shall be installed upstream from all plumbing fixtures and plumbing appliances and downstream from the water meter of an utility, if a meter is provided.

3. A pressure reducing valve shall not be required to be installed in a water distribution system which supplies water directly to a water pressure booster pump.

4. If the pressure available from the water main or private water supply is inadequate by calculation to provide the minimum pressures specified in subd. 1., a hydropneumatic pressure booster system or a water pressure booster pump shall be installed to increase the supply of water.

a. Each water pressure booster pump shall be provided with an automatic low pressure cut-off switch. The cut-off switch shall be located on the inlet side of the pump and shall be set to terminate the energy supplied to the pump when a positive pressure of less than 10 psig occurs.

b. A vacuum relief valve not less than one-half inch in diameter shall be installed in each water pressure tank, if the bottom of the pressure tank is more than 20 feet above any water supply outlet served by the pressure tank.

(e) *Maximum velocity.* A water distribution system shall be designed so that the flow velocity does not exceed 8 feet per second.

(f) *Minimum sizes.* 1. Water distribution piping 1/2" in diameter serving 2 or more plumbing fixtures may not have a load of more than 2 water supply fixture units.

2. Water distribution piping 1/2" in diameter serving a shower which is not individually pressure balanced or individually thermostatically blended may not serve any additional fixtures.

(g) *Minimum sizes for fixture supplies.* Except as provided in subds. 1. to 3., the fixture supplies serving all plumbing fixtures, appliances and pieces of equipment shall be at least 1/2" in diameter.

1. Fixture supplies serving syphon jet type urinals shall be at least 3/4" in diameter.

2. Fixture supplies serving flushometer type water closets shall be at least one inch in diameter.

3. Fixture supplies serving emergency eye wash or shower outlets shall be not less than recommended by the manufacturer.

(h) *Maximum lengths of fixture supply connectors.* 1. a. Except as provided in subd. 1. b. and c., fixture supply connectors may not exceed more than 24" in developed length upstream from a plumbing fixture or the body of a faucet.

b. A fixture supply connector located downstream of a water cooler, water treatment device or water heater which individually serves a faucet or outlet may not exceed more than 10 feet in developed length.

c. A fixture supply connector located upstream of a water treatment device serving no more than 2 fixtures or outlets may not exceed 10 feet in developed length.

2. Fixture supply connectors may not extend more than 10 feet in developed length upstream of a plumbing appliance.

(8) *INSTALLATION.* (a) *Frost protection.* 1. Adequate measures shall be taken to protect all portions of the water supply system from freezing. All private water mains and water services shall be installed below the predicted depths of frost specified in s. Comm 82.30 (11) (c) 2. d., Figure 82.30-1 and Table 82.30-6, unless other protective measures from freezing are taken.

2. A hose bibb or a hydrant that penetrates an exterior wall of a heated structure shall be a frost proof and self-draining type.

Note: See s. Comm 82.41 (4) (m) relative to cross connection control devices.

(b) *Location.* 1. Exterior water supply piping may not be located in, under or above sanitary sewer manholes, or POWTS treatment, holding or dispersal components.

2. Exterior water supply piping shall be located at least 10 feet horizontally away from a POWTS treatment, holding or dispersal component.

3. If a private water main or a water service crosses a sanitary sewer, the water piping within 10 feet of the point of crossing shall be installed:

a. At least 12" above the top of the sewer from the bottom of the water piping;

b. At least 18" below the bottom of the sewer from the top of the water piping; or

c. Within a waterproof sleeve made of materials as specified for sanitary building sewers in s. Comm 84.30 (2).

4. Private water mains and water services 2-1/2" or larger in diameter shall be installed at least 8 feet horizontally from any sanitary sewer. The distance shall be measured from center to center of the piping.

5. Except as provided in subd. 6., private water mains and water services 2" or less in diameter shall be installed at least 30" horizontally from any sanitary sewer. The distance shall be measured from center to center of the piping.

6. Private water mains and water services 2" or less in diameter may be installed less than 30" horizontally from a sanitary sewer, if the bottom of the water piping is installed at least 12" above the sewer, except that portion of a water service within 5 feet of developed length from the point where the water service first enters the building may be less than 12" above the sewer.

7. No private water main or water service may be installed within 6" of a storm sewer.

**Note:** See Appendix A-82.30 (11) (d) for setback distance from yard hydrant to well.

(c) *Limitations.* No private water main or water service may pass through or under a building to serve another building unless one of the following conditions are met:

1. The private water main or water service serves farm buildings or farm houses, or both that are all located on one property.

2. The private water main or water service serves buildings that are located on the same property and a document which indicates that the piping and distribution arrangement for the property and buildings will be recorded with the register of deeds no later than 90 days after installation.

(d) *Water distribution piping.* 1. Water distribution piping shall be supported in accordance with s. Comm 82.60.

2. Provisions shall be made to evacuate all water out of the water distribution system.

3. Except where parallel water meters are installed, water distribution piping shall be provided to bypass a water meter 1½" or larger.

4. Except as provided in subs. 5. and 6., a bypass shall be provided to serve a water treatment device. The bypass piping may be an internal part of the water treatment device.

5. A bypass shall not be required when a water treatment device serves no more than 2 fixtures or outlets.

6. A bypass shall be prohibited for a water treatment device installed to reduce a contaminant in order to comply with the provisions in s. Comm 82.70 (3).

(e) *Valves.* 1. All control valves installed in a water service, except a valve serving only as a corporation cock, shall be accessible.

2. Stop and waste-type control valves may not be installed underground.

3. All control valves and fixture stop valves installed in a water distribution system shall be accessible. Control valves for the individual plumbing fixtures and appliances within dwelling units shall be accessible from within the dwelling unit.

(f) *Water hammer arrestors.* All plumbing fixtures, appliances and appurtenances with 3/8" or larger inlet openings and with solenoid actuated quick closing valves shall be provided with water hammer arrestors. Water hammer arrestors shall be installed in the fixture supplies serving the fixtures, appliances or appurtenances. Water hammer arrestors shall be accessible.

(g) *Temperature control.* The water temperature to all showers in public buildings shall be controlled by thermostatic or combination thermostatic-pressure balanced mixing valves or by individually controlled pressure balanced mixing valves. A thermostatic or combination thermostatic-pressure balanced mixing valve may not be bypassed.

(h) *Fittings and connections.* The drilling and tapping of water supply piping shall be prohibited except for:

1. Corporation cocks for a water service or a private water main; and

2. Self-tapping valves which serve individual plumbing appliances.

(i) *Flushing and disinfection of potable water supply systems.*

1. a. Before a newly constructed water supply system is to be put into use, the piping of the system shall be filled with water and allowed to stand for at least 24 hours. After 24 hours each water outlet shall be flushed beginning with the outlet closest to the building control valve and then each successive outlet in the system. The flushing at each water outlet shall continue for at least one minute and until the water appears clear at the outlet.

b. Each portion of a water supply system which is altered or repaired shall be flushed for at least one minute and until the water appears clear.

2. New private water mains and extensions to private water mains shall be disinfected prior to use in accordance with AWWA C651 or the following method:

a. The pipe system shall be flushed with clean water until no dirty water appears at the points of outlet.

b. The system or part thereof shall be filled with a solution of water and chlorine containing at least 50 parts per million of chlorine and the system or part thereof shall be valved off and allowed to stand for 24 hours or the system or part thereof shall be filled with a solution of water and chlorine containing at least 200 parts per million of chlorine and allowed to stand for 3 hours.

c. Following the allowed standing time, the system shall be flushed with clean potable water.

d. The procedures shall be repeated if it is shown by a bacteriological examination that contamination still exists in the system.

3. The department may require a water quality analysis to be done for a new or repaired water supply system. The analysis shall be performed in accordance with acceptable nationally recognized laboratory practices. If the water supply system has been disinfected, water samples for the analysis may not be taken sooner than 24 hours after disinfection.

**Note:** See s. Comm 84.30 (1) regarding the bending of pipe and protection from puncture.

(j) *Water softeners.* Ion exchange water softeners used primarily for water hardness reduction that, during regeneration, discharge a brine solution into a private onsite wastewater treatment system shall be of a demand initiated regeneration type equipped with a water meter or a sensor unless the design of the private onsite wastewater treatment system specifically documents the reduction of chlorides.

(9) **PIPING BY PLUMBER.** In accordance with ch. 145, Stats., piping which conveys water for human use or consumption, or to plumbing fixtures and plumbing appliances of every description, shall be installed by persons licensed by the department.

(a) Private water mains and water services shall be installed by persons licensed by the department as a plumber or utility contractor.

(b) Water distribution piping shall be installed by persons licensed by the department as a plumber.

(c) Except for automatic fire sprinkler systems, piping or piping systems, which may include water heating or water treatment equipment, and which convey water not for human use or consumption from a water distribution system to water using equipment, are not required to be installed by persons licensed by the department.

(d) Where a pipe or piping system, which conveys water not for human use or consumption, connects to a water distribution system, that connection shall be provided with an approved means of backflow prevention in accordance with s. Comm 82.41. The means of backflow prevention shall be installed by persons licensed by the department as a plumber.

**History:** 1-2-56; r. and recr. Register, November, 1972, No. 203, eff. 12-1-72; r. and recr. Register, February, 1979, No. 278, eff. 3-1-79; renun. from H 62.13, Register, July, 1983, No. 331, eff. 8-1-83; renun. from ILHR 82.13 and r. and recr. (2) (b) and (4) (d) 1., am. (4) (c) 3. and (6) (a) (intro.), cr. (6) (b), Register, February, 1985, No. 350, eff. 3-1-85; r. and recr. Register, May, 1988, No. 389, eff. 6-1-88; am. (5) (d) 5. a., r. and recr. (7) (h) 1. and (8) (c), renun. (8) (c) 2. to 6. to be (8) (b) 4. to 8. and am. (8) (b) 4. c., Register, August, 1991, No. 428, eff. 9-1-91; am. (8) (b) 1. and 2., Register, April, 1992, No. 436, eff. 5-1-92; renun. (3) (c) and (8) (a) to be (3) (c) 2. and (8) (a) 1. and am. (8) (a) 1., cr. (3) (c) 1., (e), (8) (a) 2. and Table 82.40-9, am. (7) (c), r. (3) (b) 1. b. and c., Register, February, 1994, No. 458, eff. 3-1-94; r. (5) (b) 3., renun. (5) (b) 4., 5. to be (5) (b) 3., 4., Register, December, 1996, No. 480, eff. 4-1-96; correction in (5) (b) 3., made under s. 13.93 (2m) (b) 7., Stats., Register, October, 1996, No. 490; r. and recr. (5) (b), Register, February, 1997, No. 494, eff. 4-1-97; reprinted to restore dropped copy, Register, April, 1997, No. 496; am. (3) (e) and (8) (b) 1. and 2., r. (8) (b) 3. and cr. (3) (f) and (8) (j), Register, April, 2000, No. 532, eff. 7-1-00; except (3) (f) eff. 5-1-00; cr. (3) (d) 3., am. (8) (g) and (i) 2., Register, December, 2000, No. 540, eff. 1-1-01; except (3) (d) 3., eff. 9-1-01; CR 02-002: r. and recr. (3) (a), (d) 1. (intro.) to b., (7) (h), (8) (c) and Tables 82.40-4 to 11, cr. (3) (a) 2., (c) 3. and (d) 1. b., am. (3) (b) 1., (4) (c) 1. b. and 2. b., (7) (d) 1. a. and b., (8) (d) 4., (g), and Tables 82.40-1 and 2, r. (3) (e), renun. (3) (f) and (8) (b) 4. to 8. to be (3) (e) and (8) (b) 3. to 7., Register April 2003 No. 568, eff. 5-1-03; CR 02-129: am. (4) (c) 1. b., correction in (8) (b) 5. made under s. 13.93 (2m) b. 7., Stats., Register January 2004 No. 577.

Table 82.40-4  
 MAXIMUM ALLOWABLE LOAD FOR COPPER TUBING-TYPE K, ASTM B88; (C=150)

Pressure Loss Due to Friction (in lbs. per 100 ft. of Length)	Pipe Diameter (in inches)																													
	1/2"			3/4"			1"			1 1/4"			1 1/2"			2"			2 1/2"			3"			4"					
	GPM	FM	WSFU	GPM	FM	WSFU	GPM	FM	WSFU	GPM	FM	WSFU	GPM	FM	WSFU	GPM	FM	WSFU	GPM	FM	WSFU	GPM	FM	WSFU	GPM	FM	WSFU			
0.5	-	0.5	1.5	-	1.5	3.5	-	3.5	6.5	-	8.0	10.5	4.0	14.0	22.0	7.0	35.0	47.0	42.0	116	83.0	160	290	132	437	538	132	437	538	
1	-	1.0	2.5	-	2.5	5.0	-	5.0	9.5	-	12.5	15.5	5.0	22.5	32.0	16.0	60.0	83.0	60.0	192	132	290	132	437	538	192	330	330	882	
2	-	1.0	3.5	-	3.5	7.5	-	7.5	14.0	-	20.0	22.0	7.0	35.0	47.0	42.0	116	83.0	160	290	132	437	538	279	1611	1611	1611	1611	1611	
3	-	1.5	4.5	-	4.5	9.5	-	9.5	17.5	-	25.5	28.0	11.0	50.0	58.0	70.0	165	103	261	390	165	661	723	291	1725	1725	1725	1725	1725	
4	-	2.0	5.0	-	5.0	11.5	-	11.5	20.5	-	31.0	32.0	16.0	60.0	68.0	100	215	116	338	455	165	665	726	291	1725	1725	1725	1725	1725	
5	-	2.0	6.0	-	6.0	13.0	-	13.0	23.0	-	37.0	36.0	22.0	73.0	75.0	128	250	116	338	455	165	665	726	291	1725	1725	1725	1725	1725	
6	-	2.5	6.5	-	6.5	14.0	-	14.0	25.0	-	42.0	40.0	30.0	86.0	86.0	NP	NP	116	338	455	165	665	726	291	1725	1725	1725	1725	1725	
7	-	2.5	7.0	-	7.0	15.5	-	15.5	28.0	-	50.0	50.0	34.0	103	103	NP	NP	116	338	455	165	665	726	291	1725	1725	1725	1725	1725	
8	-	3.0	7.5	-	7.5	16.5	-	16.5	30.0	-	55.0	55.0	NP	NP	NP	NP	NP	116	338	455	165	665	726	291	1725	1725	1725	1725	1725	1725
9	-	3.0	8.0	-	8.0	17.5	-	17.5	30.0	-	NP	NP	NP	NP	NP	NP	NP	116	338	455	165	665	726	291	1725	1725	1725	1725	1725	1725
10	-	3.5	8.5	-	8.5	18.5	-	18.5	30.0	-	NP	NP	NP	NP	NP	NP	NP	116	338	455	165	665	726	291	1725	1725	1725	1725	1725	1725
11	-	3.5	9.0	-	9.0	19.0	-	19.0	30.0	-	NP	NP	NP	NP	NP	NP	NP	116	338	455	165	665	726	291	1725	1725	1725	1725	1725	1725
12	-	3.5	9.5	-	9.5	20.0	-	20.0	30.0	-	NP	NP	NP	NP	NP	NP	NP	116	338	455	165	665	726	291	1725	1725	1725	1725	1725	1725
13	-	4.0	10.0	-	10.0	21.5	-	21.5	30.0	-	NP	NP	NP	NP	NP	NP	NP	116	338	455	165	665	726	291	1725	1725	1725	1725	1725	1725
14	-	4.0	10.5	-	10.5	22.5	-	22.5	30.0	-	NP	NP	NP	NP	NP	NP	NP	116	338	455	165	665	726	291	1725	1725	1725	1725	1725	1725
15	-	4.0	10.5	-	10.5	23.5	-	23.5	30.0	-	NP	NP	NP	NP	NP	NP	NP	116	338	455	165	665	726	291	1725	1725	1725	1725	1725	1725
16	-	4.5	5.0	-	5.0	NP	-	NP	NP	-	NP	NP	NP	NP	NP	NP	NP	NP	NP	NP	NP	NP	NP	NP	NP	NP	NP	NP	NP	
17	-	4.5	5.0	-	5.0	NP	-	NP	NP	-	NP	NP	NP	NP	NP	NP	NP	NP	NP	NP	NP	NP	NP	NP	NP	NP	NP	NP	NP	
18	-	4.5	5.0	-	5.0	NP	-	NP	NP	-	NP	NP	NP	NP	NP	NP	NP	NP	NP	NP	NP	NP	NP	NP	NP	NP	NP	NP	NP	
19	-	5.0	6.0	-	6.0	NP	-	NP	NP	-	NP	NP	NP	NP	NP	NP	NP	NP	NP	NP	NP	NP	NP	NP	NP	NP	NP	NP	NP	

Note: WSFU means water supply fixture units.  
 GPM means gallons per minute.  
 FM means predominately flushometer type water closets or syphon jet urinals.  
 FT means predominately flush tank type water closets or wash down urinals.  
 NP means not permitted, velocities exceed 8 feet per second.  
 For using this table, round the calculated pressure loss due to friction to the next higher number shown.  
 Comm 82.40 (7) (f) and (g) specifies minimum sizes for water distribution piping.

Table 82.40-5  
**MAXIMUM ALLOWABLE LOAD FOR COPPER TUBING-TYPE L, ASTM B88; (C=150)**

Pressure Loss Due to Friction (in lbs. per 100 ft. of Length)	Pipe Diameter (in inches)																													
	1/2"		3/4"		1"		1 1/4"		1 1/2"		2"		2 1/2"		3"		4"													
	GPM	WSFU FM FT	GPM	WSFU FM FT	GPM	WSFU FM FT	GPM	WSFU FM FT	GPM	WSFU FM FT	GPM	WSFU FM FT	GPM	WSFU FM FT	GPM	WSFU FM FT	GPM	WSFU FM FT												
0.5	0.5	-	0.5	2.0	-	2.0	4.0	-	4.0	7.0	-	9.0	11.0	4.0	15.0	23.0	7.5	37.0	40.0	30.0	86.0	65.0	90.0	200	136	462	561			
1	1.0	-	1.0	2.5	-	2.5	5.5	-	6.5	10.0	4.0	13.0	16.0	5.0	23.0	33.0	17.5	63.0	59.0	72.0	170	94.0	211	345	198	909	923			
2	1.5	-	1.5	4.0	-	4.0	8.5	-	10.5	14.5	4.5	20.5	23.0	7.5	37.0	48.0	44.0	120	86.0	175	305	137	468	566	288	1694	1694			
3	2.0	-	2.0	5.0	-	6.0	10.5	4.0	14.0	18.5	6.0	27.5	29.0	12.5	52.0	60.0	75.0	175	107	283	410	169	698	752	298	1792	1792			
4	2.0	-	2.0	6.0	-	7.0	12.0	4.0	16.5	21.5	7.0	33.0	34.0	18.5	66.0	70.0	108	225	119	356	469	NP	NP	NP	NP	NP	NP			
5	2.5	-	2.5	6.5	-	8.0	14.0	4.5	20.0	24.0	8.0	40.0	38.0	26.0	80.0	77.0	136	260	NP	NP	NP	NP	NP	NP	NP	NP	NP	NP		
6	2.5	-	2.5	7.5	-	9.5	15.5	5.0	22.5	26.0	9.0	45.0	42.0	33.0	100	NP	NP	NP	NP	NP	NP	NP	NP	NP	NP	NP	NP	NP		
7	3.0	-	3.0	8.0	-	10.0	16.5	5.5	24.0	29.0	12.5	52.0	44.0	37.0	107	NP	NP	NP	NP	NP	NP	NP	NP	NP	NP	NP	NP	NP	NP	
8	3.0	-	3.0	8.5	-	10.5	18.0	6.0	26.5	31.0	15.0	58.0	NP	NP	NP	NP	NP	NP	NP	NP	NP	NP	NP	NP	NP	NP	NP	NP	NP	
9	3.5	-	3.5	9.5	-	12.5	19.0	6.0	28.0	NP	NP	NP	NP	NP	NP	NP	NP	NP	NP	NP	NP	NP	NP	NP	NP	NP	NP	NP	NP	
10	3.5	-	3.5	10.0	4.0	13.0	20.0	6.5	30.0	NP	NP	NP	NP	NP	NP	NP	NP	NP	NP	NP	NP	NP	NP	NP	NP	NP	NP	NP	NP	
11	4.0	-	4.0	10.5	4.0	14.0	20.5	6.5	31.0	NP	NP	NP	NP	NP	NP	NP	NP	NP	NP	NP	NP	NP	NP	NP	NP	NP	NP	NP	NP	
12	4.0	-	4.0	11.0	4.0	15.0	NP	NP	NP	NP	NP	NP	NP	NP	NP	NP	NP	NP	NP	NP	NP	NP	NP	NP	NP	NP	NP	NP	NP	NP
13	4.0	-	4.0	11.5	4.0	15.5	NP	NP	NP	NP	NP	NP	NP	NP	NP	NP	NP	NP	NP	NP	NP	NP	NP	NP	NP	NP	NP	NP	NP	NP
14	4.5	-	5.0	12.0	4.0	16.5	NP	NP	NP	NP	NP	NP	NP	NP	NP	NP	NP	NP	NP	NP	NP	NP	NP	NP	NP	NP	NP	NP	NP	NP
15	4.5	-	5.0	NP	NP	NP	NP	NP	NP	NP	NP	NP	NP	NP	NP	NP	NP	NP	NP	NP	NP	NP	NP	NP	NP	NP	NP	NP	NP	NP
16	5.0	-	6.0	NP	NP	NP	NP	NP	NP	NP	NP	NP	NP	NP	NP	NP	NP	NP	NP	NP	NP	NP	NP	NP	NP	NP	NP	NP	NP	NP
17	5.0	-	6.0	NP	NP	NP	NP	NP	NP	NP	NP	NP	NP	NP	NP	NP	NP	NP	NP	NP	NP	NP	NP	NP	NP	NP	NP	NP	NP	NP
18	5.0	-	6.0	NP	NP	NP	NP	NP	NP	NP	NP	NP	NP	NP	NP	NP	NP	NP	NP	NP	NP	NP	NP	NP	NP	NP	NP	NP	NP	NP
19	5.0	-	6.0	NP	NP	NP	NP	NP	NP	NP	NP	NP	NP	NP	NP	NP	NP	NP	NP	NP	NP	NP	NP	NP	NP	NP	NP	NP	NP	NP
20	5.5	-	6.5	NP	NP	NP	NP	NP	NP	NP	NP	NP	NP	NP	NP	NP	NP	NP	NP	NP	NP	NP	NP	NP	NP	NP	NP	NP	NP	NP

Note:WSFU means water supply fixture units.

GPM means gallons per minute.

FM means predominately flushometer type water closets or syphon jet urinals.

FT means predominately flush tank type water closets or wash down urinals.

NP means not permitted, velocities exceed 8 feet per second.

For using this table, round the calculated pressure loss due to friction to the next higher number shown.

Comm 82.40 (7) (f) and (g) specifies minimum sizes for water distribution piping.

**Table 82.40-6  
MAXIMUM ALLOWABLE LOAD FOR COPPER TUBING-TYPE M, ASTM B88; (C=150)**

Pressure Loss Due to Friction (in lbs. per 100 ft. of Length)	Pipe Diameter (in inches)																																		
	1/2"		3/4"		1"		1 1/4"		1 1/2"		2"		2 1/2"		3"		4"																		
	GPM	WSFU FM FT	GPM	WSFU FM FT	GPM	WSFU FM FT	GPM	WSFU FM FT	GPM	WSFU FM FT	GPM	WSFU FM FT	GPM	WSFU FM FT	GPM	WSFU FM FT	GPM	WSFU FM FT																	
0.5	0.5	-	2.0	-	2.0	4.0	-	4.0	7.0	-	9.0	11.5	4.0	15.5	23.0	7.5	37.0	42.0	33.0	100	67.0	96.0	210	139	481	577									
1	1.0	-	3.0	-	3.0	6.0	-	7.0	10.5	4.0	14.0	16.5	5.5	24.0	34.0	18.5	66.0	61.0	77.0	180	97.0	227	360	202	945	953									
2	1.5	-	4.5	-	5.0	9.0	-	11.5	15.5	5.0	22.5	24.0	8.0	40.0	50.0	48.0	128	88.0	184	315	141	493	588	294	1750	1750									
3	2.0	-	5.5	-	6.5	11.5	4.0	15.5	19.5	6.5	29.0	30.0	13.5	55.0	62.0	80.0	185	110	300	425	174	731	776	303	1835	1835									
4	2.5	-	6.5	-	8.0	13.0	4.5	18.0	22.0	7.0	35.0	35.0	20.0	70.0	73.0	120	240	121	374	484	NP	NP	NP	NP	NP	NP	NP								
5	2.5	-	7.5	-	9.5	15.0	5.0	21.5	25.0	8.5	42.0	40.0	30.0	86.0	79.0	144	270	NP	NP	NP	NP	NP	NP	NP	NP	NP	NP	NP							
6	3.0	-	8.0	-	10.0	16.5	5.5	24.0	28.0	11.0	50.0	44.0	36.0	106	NP	NP	NP	NP	NP	NP	NP	NP	NP	NP	NP	NP	NP	NP							
7	3.5	-	9.0	-	11.5	18.0	6.0	26.5	30.0	13.5	55.0	45.0	39.0	112	NP	NP	NP	NP	NP	NP	NP	NP	NP	NP	NP	NP	NP	NP	NP						
8	3.5	-	9.5	-	12.5	19.5	6.5	29.0	32.0	17.0	62.0	NP	NP	NP	NP	NP	NP	NP	NP	NP	NP	NP	NP	NP	NP	NP	NP	NP	NP	NP					
9	4.0	-	10.0	4.0	13.0	20.5	6.5	31.0	NP	NP	NP	NP	NP	NP	NP	NP	NP	NP	NP	NP	NP	NP	NP	NP	NP	NP	NP	NP	NP	NP					
10	4.0	-	11.0	4.0	15.0	21.5	7.0	34.0	NP	NP	NP	NP	NP	NP	NP	NP	NP	NP	NP	NP	NP	NP	NP	NP	NP	NP	NP	NP	NP	NP	NP				
11	4.5	-	11.5	4.0	15.5	NP	NP	NP	NP	NP	NP	NP	NP	NP	NP	NP	NP	NP	NP	NP	NP	NP	NP	NP	NP	NP	NP	NP	NP	NP	NP				
12	4.5	-	12.0	4.0	16.5	NP	NP	NP	NP	NP	NP	NP	NP	NP	NP	NP	NP	NP	NP	NP	NP	NP	NP	NP	NP	NP	NP	NP	NP	NP	NP	NP			
13	5.0	-	12.5	4.5	17.5	NP	NP	NP	NP	NP	NP	NP	NP	NP	NP	NP	NP	NP	NP	NP	NP	NP	NP	NP	NP	NP	NP	NP	NP	NP	NP	NP			
14	5.0	-	12.5	4.5	18.0	NP	NP	NP	NP	NP	NP	NP	NP	NP	NP	NP	NP	NP	NP	NP	NP	NP	NP	NP	NP	NP	NP	NP	NP	NP	NP	NP	NP		
15	5.0	-	6.0	NP	NP	NP	NP	NP	NP	NP	NP	NP	NP	NP	NP	NP	NP	NP	NP	NP	NP	NP	NP	NP	NP	NP	NP	NP	NP	NP	NP	NP	NP		
16	5.5	-	6.5	NP	NP	NP	NP	NP	NP	NP	NP	NP	NP	NP	NP	NP	NP	NP	NP	NP	NP	NP	NP	NP	NP	NP	NP	NP	NP	NP	NP	NP	NP	NP	
17	5.5	-	6.5	NP	NP	NP	NP	NP	NP	NP	NP	NP	NP	NP	NP	NP	NP	NP	NP	NP	NP	NP	NP	NP	NP	NP	NP	NP	NP	NP	NP	NP	NP	NP	
18	5.5	-	6.5	NP	NP	NP	NP	NP	NP	NP	NP	NP	NP	NP	NP	NP	NP	NP	NP	NP	NP	NP	NP	NP	NP	NP	NP	NP	NP	NP	NP	NP	NP	NP	NP
19	6.0	-	7.0	NP	NP	NP	NP	NP	NP	NP	NP	NP	NP	NP	NP	NP	NP	NP	NP	NP	NP	NP	NP	NP	NP	NP	NP	NP	NP	NP	NP	NP	NP	NP	NP
20	6.0	-	7.0	NP	NP	NP	NP	NP	NP	NP	NP	NP	NP	NP	NP	NP	NP	NP	NP	NP	NP	NP	NP	NP	NP	NP	NP	NP	NP	NP	NP	NP	NP	NP	NP
21	6.0	-	7.5	NP	NP	NP	NP	NP	NP	NP	NP	NP	NP	NP	NP	NP	NP	NP	NP	NP	NP	NP	NP	NP	NP	NP	NP	NP	NP	NP	NP	NP	NP	NP	NP

Note: WSFU means water supply fixture units.

GPM means gallons per minute.

FM means predominately flushometer type water closets or syphon jet urinals.

FT means predominately flush tank type water closets or wash down urinals.

NP means not permitted, velocities exceed 8 feet per second.

For using this table, round the calculated pressure loss due to friction

to the next higher number shown.

Comm 82.40 (7) (f) and (g) specifies minimum sizes for water distribution piping.

**Table 82.40-7  
MAXIMUM ALLOWABLE LOAD FOR GALVANIZED STEEL PIPE, SCHEDULE 40, ASTM A53; (C=150)**

Pressure Loss Due to Friction (in lbs. per 100 ft. of Length)	Pipe Diameter (in inches)																											
	1/2"		3/4"		1"		1 1/4"		1 1/2"		2"		2 1/2"		3"		4"											
	GPM	WSFU	GPM	WSFU	GPM	WSFU	GPM	WSFU	GPM	WSFU	GPM	WSFU	GPM	WSFU	GPM	WSFU	GPM	WSFU										
0.5	0.5	-	0.5	1.5	-	1.5	3.5	-	3.5	7.0	-	7.0	11.0	4.0	15.0	21.0	7.0	32.0	34.0	18.5	66.0	60.0	75.0	175	123	381	490	
1	1.0	-	1.0	2.5	-	2.5	5.0	-	5.0	10.5	4.0	14.0	16.0	5.0	23.0	31.0	15.0	57.0	49.0	46.0	124	87.0	180	310	179	769	805	
2	1.5	-	1.5	4.0	-	4.0	7.5	-	7.5	15.5	5.0	22.5	23.0	7.5	37.0	45.0	38.0	110	72.0	116	235	127	406	511	260	1435	1435	
3	2.0	-	2.0	5.0	-	5.0	9.0	-	9.0	19.0	6.0	28.0	29.0	12.5	52.0	56.0	65.0	155	89.0	188	320	158	607	683	317	1966	1966	
4	2.5	-	2.5	5.5	-	5.5	11.0	4.0	15.0	22.0	7.0	35.0	34.0	18.5	66.0	65.0	90	200	104	266	395	184	809	837	NP	NP	NP	
5	3.0	-	3.0	6.5	-	6.5	12.0	4.0	16.5	25.0	8.5	42.0	38.0	26.0	80.0	74.0	124	245	118	350	465	NP	NP	NP	NP	NP	NP	
6	3.0	-	3.0	7.0	-	7.0	13.5	4.5	19.0	28.0	11.0	50.0	42.0	33.0	100	81.0	152	280	119	358	471	NP	NP	NP	NP	NP	NP	
7	3.5	-	3.5	7.5	-	7.5	14.5	4.5	20.5	30.0	13.5	55.0	46.0	40.0	113	83.0	163	293	NP	NP	NP	NP	NP	NP	NP	NP	NP	
8	4.0	-	4.0	8.0	-	8.0	16.0	5.0	23.0	33.0	17.5	63.0	49.0	46.0	124	NP	NP	NP	NP	NP	NP	NP	NP	NP	NP	NP	NP	NP
9	4.0	-	4.0	9.0	-	9.0	17.0	5.5	25.0	35.0	20.0	70.0	50.0	49.0	131	NP	NP	NP	NP	NP	NP	NP	NP	NP	NP	NP	NP	NP
10	4.5	-	4.5	9.5	-	9.5	18.0	6.0	26.5	37.0	24.0	76.0	NP	NP	NP	NP	NP	NP	NP	NP	NP	NP	NP	NP	NP	NP	NP	NP
11	4.5	-	4.5	10.0	4.0	13.0	19.0	6.0	28.0	37.0	24.0	77.0	NP	NP	NP	NP	NP	NP	NP	NP	NP	NP	NP	NP	NP	NP	NP	NP
12	5.0	-	5.0	10.5	4.0	14.0	19.5	6.5	29.0	NP	NP	NP	NP	NP	NP	NP	NP	NP	NP	NP	NP	NP	NP	NP	NP	NP	NP	NP
13	5.0	-	5.0	11.0	4.0	15.0	20.5	6.5	31.0	NP	NP	NP	NP	NP	NP	NP	NP	NP	NP	NP	NP	NP	NP	NP	NP	NP	NP	NP
14	5.0	-	5.0	11.0	4.0	15.0	21.5	7.0	33.0	NP	NP	NP	NP	NP	NP	NP	NP	NP	NP	NP	NP	NP	NP	NP	NP	NP	NP	NP
15	5.5	-	5.5	11.5	4.0	15.5	NP	NP	NP	NP	NP	NP	NP	NP	NP	NP	NP	NP	NP	NP	NP	NP	NP	NP	NP	NP	NP	NP
16	5.5	-	5.5	12.0	4.0	16.5	NP	NP	NP	NP	NP	NP	NP	NP	NP	NP	NP	NP	NP	NP	NP	NP	NP	NP	NP	NP	NP	NP
17	6.0	-	6.0	12.5	4.5	17.5	NP	NP	NP	NP	NP	NP	NP	NP	NP	NP	NP	NP	NP	NP	NP	NP	NP	NP	NP	NP	NP	NP
18	6.0	-	6.0	13.0	4.5	18.0	NP	NP	NP	NP	NP	NP	NP	NP	NP	NP	NP	NP	NP	NP	NP	NP	NP	NP	NP	NP	NP	NP
19	6.0	-	6.0	13.0	4.5	18.5	NP	NP	NP	NP	NP	NP	NP	NP	NP	NP	NP	NP	NP	NP	NP	NP	NP	NP	NP	NP	NP	NP
20	6.5	-	6.5	8.0	NP	NP	NP	NP	NP	NP	NP	NP	NP	NP	NP	NP	NP	NP	NP	NP	NP	NP	NP	NP	NP	NP	NP	NP
21	6.5	-	6.5	8.0	NP	NP	NP	NP	NP	NP	NP	NP	NP	NP	NP	NP	NP	NP	NP	NP	NP	NP	NP	NP	NP	NP	NP	NP
22	7.0	-	7.0	9.0	NP	NP	NP	NP	NP	NP	NP	NP	NP	NP	NP	NP	NP	NP	NP	NP	NP	NP	NP	NP	NP	NP	NP	NP
23	7.0	-	7.0	9.0	NP	NP	NP	NP	NP	NP	NP	NP	NP	NP	NP	NP	NP	NP	NP	NP	NP	NP	NP	NP	NP	NP	NP	NP
24	7.0	-	7.0	9.0	NP	NP	NP	NP	NP	NP	NP	NP	NP	NP	NP	NP	NP	NP	NP	NP	NP	NP	NP	NP	NP	NP	NP	NP
25	7.5	-	7.5	9.5	NP	NP	NP	NP	NP	NP	NP	NP	NP	NP	NP	NP	NP	NP	NP	NP	NP	NP	NP	NP	NP	NP	NP	NP

Note: WSFU means water supply fixture units.  
 GPM means gallons per minute.  
 FM means predominately flushometer type water closets or syphon jet urinals.  
 FT means predominately flush tank type water closets or wash down urinals.  
 NP means not permitted, velocities exceed 8 feet per second.  
 For using this table, round the calculated pressure loss due to friction to the next higher number shown.  
 Comm 82.40 (7) (f) and (g) specifies minimum sizes for water distribution piping.

**Table 82.40-8**  
**MAXIMUM ALLOWABLE LOAD FOR POLYBUTYLENE TUBING, ASTM D3309 and**  
**CHLORINATED POLYVINYL CHLORIDE TUBING, ASTM D2846; (C=150)**

Pressure Loss Due to Friction (in lbs. per 100 ft. of Length)	Pipe Diameter (in inches)																	
	1/2"			3/4"			1"			1 1/4"			1 1/2"			2"		
	GPM	WSFU FM	FT	GPM	WSFU FM	FT	GPM	WSFU FM	FT	GPM	WSFU FM	FT	GPM	WSFU FM	FT	GPM	WSFU FM	FT
0.5	0.5	-	0.5	1.5	-	1.5	3.0	-	3.0	5.0	-	6.0	8.0	-	10.0	16.0	5.0	23.0
1	0.5	-	0.5	2.0	-	2.0	4.0	-	4.0	7.5	-	9.5	11.5	4.0	15.5	23.0	7.5	37.0
2	1.0	-	1.0	3.0	-	3.0	6.0	-	7.0	10.5	4.0	14.0	16.5	5.5	24.0	34.0	18.5	66.0
3	1.5	-	1.5	4.0	-	4.0	8.0	-	10.0	13.5	4.5	19.0	21.0	7.0	32.0	42.0	33.0	100
4	1.5	-	1.5	4.5	-	5.0	9.0	-	11.5	15.5	5.0	22.5	24.0	8.0	40.0	50.0	48.0	128
5	2.0	-	2.0	5.0	-	6.0	10.5	4.0	14.0	17.5	5.5	25.5	27.0	10.0	47.0	56.0	65.0	155
6	2.0	-	2.0	6.0	-	7.0	11.5	4.0	15.5	19.5	6.5	29.0	30.0	13.5	55.0	59.0	73.0	171
7	2.0	-	2.0	6.5	-	8.0	12.5	4.5	17.5	21.5	7.0	33.0	33.0	17.5	63.0	NP	NP	NP
8	2.5	-	2.5	7.0	-	9.0	13.5	4.5	19.0	23.0	7.5	37.0	34.0	19.0	68.0	NP	NP	NP
9	2.5	-	2.5	7.0	-	9.0	14.5	4.5	20.5	24.0	8.0	40.0	NP	NP	NP	NP	NP	NP
10	2.5	-	2.5	7.5	-	9.5	15.0	5.0	21.5	24.0	8.0	41.0	NP	NP	NP	NP	NP	NP
11	3.0	-	3.0	8.0	-	10.0	16.0	5.0	23.0	NP	NP	NP	NP	NP	NP	NP	NP	NP
12	3.0	-	3.0	8.5	-	10.5	16.5	5.5	24.0	NP	NP	NP	NP	NP	NP	NP	NP	NP
13	3.0	-	3.0	9.0	-	11.5	NP	NP	NP	NP	NP	NP	NP	NP	NP	NP	NP	NP
14	3.0	-	3.0	9.5	-	12.5	NP	NP	NP	NP	NP	NP	NP	NP	NP	NP	NP	NP
15	3.5	-	3.5	9.5	-	12.5	NP	NP	NP	NP	NP	NP	NP	NP	NP	NP	NP	NP
16	3.5	-	3.5	10.0	4.0	13.0	NP	NP	NP	NP	NP	NP	NP	NP	NP	NP	NP	NP
17	3.5	-	3.5	NP	NP	NP	NP	NP	NP	NP	NP	NP	NP	NP	NP	NP	NP	NP
18	4.0	-	4.0	NP	NP	NP	NP	NP	NP	NP	NP	NP	NP	NP	NP	NP	NP	NP
19	4.0	-	4.0	NP	NP	NP	NP	NP	NP	NP	NP	NP	NP	NP	NP	NP	NP	NP
20	4.0	-	4.0	NP	NP	NP	NP	NP	NP	NP	NP	NP	NP	NP	NP	NP	NP	NP
21	4.0	-	4.0	NP	NP	NP	NP	NP	NP	NP	NP	NP	NP	NP	NP	NP	NP	NP
22	4.0	-	4.0	NP	NP	NP	NP	NP	NP	NP	NP	NP	NP	NP	NP	NP	NP	NP
23	4.5	-	5.0	NP	NP	NP	NP	NP	NP	NP	NP	NP	NP	NP	NP	NP	NP	NP

Note: WSFU means water supply fixture units.

GPM means gallons per minute.

FM means predominately flushometer type water closets or syphon jet urinals.

FT means predominately flush tank type water closets or wash down urinals.

NP means not permitted, velocities exceed 8 feet per second.

For using this table, round the calculated pressure loss due to friction to the next higher number shown.

Comm 82.40 (7) (f) and (g) specifies minimum sizes for water distribution piping.

Table 82.40-9

**MAXIMUM ALLOWABLE LOAD FOR CROSSLINKED POLYETHYLENE (PEX) TUBING, ASTM F876 and F877; (C=150)**

Pressure Loss Due to Friction (in lbs. per 100 ft. of Length)	Pipe Diameter (in inches)																					
	1/2"			5/8"			3/4"			1"			1 1/4"			1 1/2"			2"			
	GPM	WSFU FM	FT	GPM	WSFU FM	FT	GPM	WSFU FM	FT	GPM	WSFU FM	FT	GPM	WSFU FM	FT	GPM	WSFU FM	FT	GPM	WSFU FM	FT	
0.5	0.5	-	0.5	0.5	-	0.5	1.0	-	1.0	2.5	-	2.5	4.0	-	4.0	6.0	-	6.0	13.5	-	13.5	19.0
1	0.5	-	0.5	1.0	-	1.0	1.5	-	1.5	3.5	-	3.5	6.0	-	6.0	9.0	-	9.0	19.5	-	19.5	29.0
2	1.0	-	1.0	1.5	-	1.5	2.5	-	2.5	5.0	-	5.0	9.0	-	9.0	13.5	-	13.5	28.0	-	28.0	50.0
3	1.0	-	1.0	2.0	-	2.0	3.0	-	3.0	6.5	-	6.5	11.0	-	11.0	17.0	-	17.0	36.0	-	36.0	73.0
4	1.5	-	1.5	2.5	-	2.5	4.0	-	4.0	7.5	-	7.5	13.0	-	13.0	19.5	-	19.5	42.0	-	42.0	100
5	1.5	-	1.5	3.0	-	3.0	4.5	-	4.5	8.5	-	8.5	15.0	-	15.0	22.0	-	22.0	47.0	-	47.0	116
6	2.0	-	2.0	3.5	-	3.5	5.0	-	5.0	9.5	-	9.5	16.5	-	16.5	24.0	-	24.0	51.0	-	51.0	135
7	2.0	-	2.0	3.5	-	3.5	5.5	-	5.5	10.5	-	10.5	18.0	-	18.0	26.0	-	26.0	NP	-	NP	NP
8	2.0	-	2.0	4.0	-	4.0	5.5	-	5.5	11.0	-	11.0	19.0	-	19.0	28.0	-	28.0	28.0	-	28.0	50.0
9	2.5	-	2.5	4.0	-	4.0	6.0	-	6.0	12.0	-	12.0	20.5	-	20.5	31.0	-	31.0	29.0	-	29.0	53.0
10	2.5	-	2.5	4.5	-	4.5	6.5	-	6.5	12.5	-	12.5	21.5	-	21.5	34.0	-	34.0	NP	-	NP	NP
11	2.5	-	2.5	4.5	-	4.5	7.0	-	7.0	13.5	-	13.5	21.5	-	21.5	NP	-	NP	NP	-	NP	NP
12	2.5	-	2.5	5.0	-	5.0	7.0	-	7.0	14.0	-	14.0	20.0	-	20.0	NP	-	NP	NP	-	NP	NP
13	3.0	-	3.0	5.0	-	5.0	7.5	-	7.5	14.5	-	14.5	20.5	-	20.5	NP	-	NP	NP	-	NP	NP
14	3.0	-	3.0	5.5	-	5.5	8.0	-	8.0	15.0	-	15.0	20.5	-	20.5	NP	-	NP	NP	-	NP	NP
15	3.0	-	3.0	5.5	-	5.5	8.0	-	8.0	15.0	-	15.0	20.5	-	20.5	NP	-	NP	NP	-	NP	NP
16	3.0	-	3.0	6.0	-	6.0	8.5	-	8.5	16.0	-	16.0	21.0	-	21.0	NP	-	NP	NP	-	NP	NP
17	3.5	-	3.5	6.0	-	6.0	8.5	-	8.5	16.0	-	16.0	21.0	-	21.0	NP	-	NP	NP	-	NP	NP
18	3.5	-	3.5	6.0	-	6.0	8.5	-	8.5	16.0	-	16.0	21.0	-	21.0	NP	-	NP	NP	-	NP	NP
19	3.5	-	3.5	6.5	-	6.5	9.0	-	9.0	17.0	-	17.0	22.0	-	22.0	NP	-	NP	NP	-	NP	NP
20	3.5	-	3.5	6.5	-	6.5	9.0	-	9.0	17.0	-	17.0	22.0	-	22.0	NP	-	NP	NP	-	NP	NP
21	4.0	-	4.0	NP	-	NP	NP	-	NP	NP	-	NP	NP	-	NP	NP	-	NP	NP	-	NP	NP

Note: WSFU means water supply fixture units.

GPM means gallons per minute.

FM means predominately flushometer type water closets or syphon jet urinals.

FT means predominately flush tank type water closets or wash down urinals.

NP means not permitted, velocities exceed 8 feet per second.

For using this table, round the calculated pressure loss due to friction to the next higher number shown.

Comm 82.40 (7) (f) and (g) specifies minimum sizes for water distribution piping.



**Table 82.40-10**  
**MAXIMUM ALLOWABLE LOAD FOR CHLORINATED POLYVINYL CHLORIDE TUBING, ASTM F442; (C=150)**

Pressure Loss Due to Friction (in lbs. per 100 ft. of Length)	Pipe Diameter (in inches)																				
	3/4"			1"			1 1/4"			1 1/2"			2"			2 1/2"			3"		
	GPM	WSFU FM	WSFU FT	GPM	WSFU FM	WSFU FT	GPM	WSFU FM	WSFU FT	GPM	WSFU FM	WSFU FT	GPM	WSFU FM	WSFU FT	GPM	WSFU FM	WSFU FT	GPM	WSFU FM	WSFU FT
0.5	2.5	-	2.5	4.5	-	5.0	9.0	-	11.5	13.0	4.5	18.0	23.0	7.5	37.0	38.0	26.0	80.0	65.0	90.0	200
1	3.5	-	3.5	7.0	-	9.0	13.0	4.5	18.0	18.5	6.0	27.5	34.0	18.5	66.0	56.0	65.0	155	94.0	211	345
2	5.5	-	6.5	10.0	4.0	13.0	19.0	6.0	28.0	27.0	10.0	47.0	49.0	46.0	124	82.0	156	285	138	475	572
3	7.0	-	9.0	12.5	4.5	17.5	23.0	7.5	37.0	34.0	18.5	66.0	62.0	80.0	185	102	255	385	170	703	755
4	8.0	-	10.0	15.0	5.0	21.5	27.0	10.0	47.0	40.0	30.0	86.0	72.0	116	235	114	331	449	NP	NP	NP
5	9.0	-	11.5	16.5	5.5	24.0	31.0	15.0	57.0	45.0	38.0	110	78.0	142	267	NP	NP	NP	NP	NP	NP
6	10.0	4.0	13.0	18.5	6.0	27.5	34.0	18.5	66.0	49.0	46.0	124	NP	NP	NP	NP	NP	NP	NP	NP	NP
7	11.0	4.0	15.0	20.0	6.5	30.0	37.0	24.0	76.0	50.0	48.0	128	NP	NP	NP	NP	NP	NP	NP	NP	NP
8	11.5	4.0	15.5	21.5	7.0	33.0	38.0	26.0	80.0	NP	NP	NP	NP	NP	NP	NP	NP	NP	NP	NP	NP
9	12.5	4.5	17.5	23.0	7.5	37.0	NP	NP	NP	NP	NP	NP	NP	NP	NP	NP	NP	NP	NP	NP	NP
10	13.0	4.5	18.0	23.0	7.5	39.0	NP	NP	NP	NP	NP	NP	NP	NP	NP	NP	NP	NP	NP	NP	NP
11	14.0	4.5	20.0	NP	NP	NP	NP	NP	NP	NP	NP	NP	NP	NP	NP	NP	NP	NP	NP	NP	NP
12	14.5	4.5	20.5	NP	NP	NP	NP	NP	NP	NP	NP	NP	NP	NP	NP	NP	NP	NP	NP	NP	NP
13	14.5	5.0	21.5	NP	NP	NP	NP	NP	NP	NP	NP	NP	NP	NP	NP	NP	NP	NP	NP	NP	NP

Note: WSFU means water supply fixture units.

GPM means gallons per minute.

FM means predominately flushometer type water closets or syphon jet urinals.

FT means predominately flush tank type water closets or wash down urinals.

NP means not permitted, velocities exceed 8 feet per second.

For using this table, round the calculated pressure loss due to friction

to the next higher number shown.

Comm 82.40 (7) (f) and (g) specifies minimum sizes for water distribution piping.

**Table 82.40-11**  
**MAXIMUM ALLOWABLE LOAD FOR POLYETHYLENE ALUMINUM POLYETHYLENE TUBING (PexAlPex), ASTM F1281; (C=150)**

Pressure Loss Due to Friction (in lbs. per 100 ft. of Length)	Pipe Diameter (in inches)															
	1/2"				5/8"				3/4"				1"			
	GPM	WSFU FM	FT		GPM	WSFU FM	FT		GPM	WSFU FM	FT		GPM	WSFU FM	FT	
0.5	0.5	-	0.5	1.0	2.0	1.0	1.0	2.0	2.0	-	2.0	4.0	4.0	-	4.0	
1	0.5	-	0.5	1.5	3.0	1.5	1.5	3.0	3.0	-	3.0	6.0	6.0	-	7.0	
2	1.0	-	1.0	2.0	4.5	2.0	2.0	4.5	4.5	-	5.0	8.5	8.5	-	10.5	
3	1.5	-	1.5	3.0	6.5	3.0	3.0	6.5	6.5	-	8.0	12.5	12.5	4.0	14.0	
4	1.5	-	1.5	3.5	7.0	3.5	3.5	7.0	7.0	-	9.0	14.0	14.0	4.5	17.5	
5	2.0	-	2.0	4.0	8.0	4.0	4.0	8.0	8.0	-	10.0	15.5	15.5	5.0	20.0	
6	2.0	-	2.0	4.5	9.5	5.0	5.0	9.5	9.5	-	11.0	17.0	17.0	5.5	22.5	
7	2.5	-	2.5	5.0	10.5	6.0	6.0	10.5	10.5	-	12.5	18.0	18.0	6.0	25.0	
8	2.5	-	2.5	5.5	11.0	6.5	6.5	11.0	11.0	-	13.0	19.5	19.5	6.5	26.5	
9	3.0	-	3.0	6.0	11.5	7.0	7.0	11.5	11.5	-	14.0	20.5	20.5	6.5	29.0	
10	3.0	-	3.0	6.5	12.5	8.0	8.0	12.5	12.5	-	15.0	20.5	20.5	6.5	31.0	
11	3.0	-	3.0	7.0	13.0	8.0	8.0	13.0	13.0	-	15.5	20.5	20.5	6.5	32.0	
12	3.0	-	3.0	7.5	13.5	8.0	8.0	13.5	13.5	-	16.0	20.5	20.5	NP	NP	
13	3.5	-	3.5	8.0	14.0	8.0	8.0	14.0	14.0	-	16.5	20.5	20.5	NP	NP	
14	3.5	-	3.5	8.5	14.5	8.0	8.0	14.5	14.5	-	17.0	20.5	20.5	NP	NP	
15	3.5	-	3.5	9.0	15.0	9.0	9.0	15.0	15.0	-	17.5	20.5	20.5	NP	NP	
16	3.5	-	3.5	9.5	15.5	9.0	9.0	15.5	15.5	-	18.0	20.5	20.5	NP	NP	
17	4.0	-	4.0	10.0	16.0	9.5	9.5	16.0	16.0	-	18.5	20.5	20.5	NP	NP	
18	4.0	-	4.0	10.5	16.5	9.5	9.5	16.5	16.5	-	19.0	20.5	20.5	NP	NP	
19	4.0	-	4.0	11.0	17.0	9.5	9.5	17.0	17.0	-	19.5	20.5	20.5	NP	NP	
20	4.0	-	4.0	11.5	17.5	9.5	9.5	17.5	17.5	-	20.0	20.5	20.5	NP	NP	
21	4.5	-	5.0	12.0	18.0	9.5	9.5	18.0	18.0	-	20.5	20.5	20.5	NP	NP	

Note: WSFU means water supply fixture units.

GPM means gallons per minute.

FM means predominately flushometer type water closets or syphon jet urinals.

FT means predominately flush tank type water closets or wash down urinals.

NP means not permitted, velocities exceed 8 feet per second.

For using this table, round the calculated pressure loss due to friction to the next higher number shown.

Comm 82.40 (7) (f) and (g) specifies minimum sizes for water distribution piping.

**Comm 82.41 Cross connection control. (1) SCOPE.** The provisions of this section set forth the requirements for the protection of potable water within water supply systems when and where there is the possibility of contamination due to cross connections or backflow conditions.

**Note:** The Department of Natural Resources governs the operation and design of community water systems and under s. NR 811.09 requires the supplier of water to develop and implement a comprehensive cross connection control program.

**(2) MATERIALS.** (a) All devices, assemblies and mechanisms intended to protect potable water supplies relative to cross connection or backflow shall be of a type recognized and approved in accordance with ch. Comm 84 and as described in sub. (4).

(b) All methods including barometric loops and air gaps intended to protect potable water supplies relative to cross connection or backflow shall be constructed of materials suitable for

water supply systems in accordance with ch. Comm 84.

**(3) GENERAL REQUIREMENTS.** Water supply systems and the connection of each plumbing fixture, piece of equipment, appliance or nonpotable water piping system shall be designed, installed and maintained in such a manner to prevent the contamination of water supplies by means of cross connections.

(a) *Types of cross connection control.* 1. Potable water supply systems shall be protected against contamination due to cross connections or backflow conditions by one of the methods or devices specified in Table 82.41-1 depending upon the situation or Table 82.41-2 depending upon the specific application or use, and the limitations specified in sub. (4).

2. For the situations described in par. (b) 3., cross connection control shall be provided as part of the fixture fitting outlet or in the water supply piping for the fixture fitting outlet.

Table 82.41-1

ACCEPTABLE CROSS CONNECTION CONTROL METHODS OR ASSEMBLIES FOR SPECIFIC APPLICATIONS

Methods or Assemblies of Cross Connection Control (Standard)	Situations and Conditions							
	Backpressure				Backsiphonage			
	Low Hazard		High Hazard		Low Hazard		High Hazard	
	Continu- ous Pressure	Noncon- tinuous Pressure	Continu- ous Pressure	Noncon- tinuous Pressure	Continu- ous Pressure	Noncon- tinuous Pressure	Continu- ous Pressure	Noncon- tinuous Pressure
Air-gap Fittings for use with Plumbing Fixtures, Appliances, and Appurtenances (ASME A112.1.3)					X	X	X	X
Air Gaps (ASME A112.1.2)	X	X	X	X	X	X	X	X
Atmospheric Type Vacuum Breaker (CAN/CSA B64.1.1)						X		X
Back Siphonage Vacuum Breaker (ASSE 1056)					X	X	X	X
Backflow Preventers with Intermediate Atmospheric Vent (ASSE 1012)	X	X			X	X		
Barometric Loops					X	X	X	X
Dual Check Valve Type with Atmospheric Port Backflow Preventer (CAN/CSA B64.3)	X	X			X	X		
Hose Connection Backflow Preventers (ASSE 1052)	X <sup>a</sup>	X	X <sup>a</sup>	X	X <sup>a</sup>	X	X <sup>a</sup>	X
Hose Connection Type Vacuum Breakers (CAN/CSA B64.2.1 and B64.2.2)	X <sup>a</sup>	X	X <sup>a</sup>	X	X <sup>a</sup>	X	X <sup>a</sup>	X
Hose Connection Vacuum Breakers (ASSE 1011)	X <sup>a</sup>	X	X <sup>a</sup>	X	X <sup>a</sup>	X	X <sup>a</sup>	X
Pipe Applied Atmospheric Type Vacuum Breakers (ASSE 1001)						X		X
Pressure Type Vacuum Breaker (CAN/CSA B64.1.2)					X	X	X	X
Pressure Vacuum Breaker Assembly (ASSE 1020)					X	X	X	X
Reduced Pressure Principle Backflow Preventers (ASSE 1013)	X	X	X	X	X	X	X	X
Reduced Pressure Principle Type Backflow Preventer (CAN/CSA B64.4)	X	X	X	X	X	X	X	X

<sup>a</sup> See limitation listed under s. Comm 82.41 (4) (c) 1. a.

**Table 82.41-2**  
**ACCEPTABLE CROSS CONNECTION CONTROL METHODS OR ASSEMBLIES FOR**  
**SPECIFIC APPLICATIONS**

Methods or Assemblies of Cross Connection Control (Standard)	Types of Application or Use
Backflow Preventer for Carbonated Beverage Machines (ASSE 1022)	Beverage dispensers
Chemical Dispensing Systems (ASSE 1055)	Chemical dispensing systems
Double Check Backflow Prevention Assemblies (ASSE 1015)	Automatic fire sprinkler systems and standpipe systems Water-based fire protection system
Double Check Detector Assembly Backflow Preventer (ASSE 1048)	Automatic fire sprinkler systems and standpipe systems Water-based fire protection system
Double Check Detector Valve Type Backflow Preventer (CAN/CSA B64.5)	Automatic fire sprinkler systems and standpipe systems Water-based fire protection system
Hand Held Showers (ASSE 1014)	Hand held shower assemblies
Laboratory Faucet Backflow Preventer (ASSE 1035)	Laboratory faucets
Laboratory Faucet Type Vacuum Breakers (CAN/CSA B64.7)	Laboratory faucets
Laboratory Faucet Vacuum Breakers (ASSE 1035)	Laboratory faucets
Pressurized Flushing Devices (Flushometers) For Plumbing Fixtures (ASSE 1037)	Flushometer plumbing fixtures
Reduced Pressure Detector Backflow Preventer (ASSE 1047)	Automatic fire sprinkler systems
Trap Seal Primer Valves, Water Supply Fed (ASSE 1018)	Traps for drain systems
Vacuum Breaker Tees [s. Comm 82.41 (5) (j)]	Water treatment devices
Wall Hydrants, Frost Proof Automatic Draining Anti-Backflow Type (ASSE 1019), types A or B	Hose threaded outlet connections
Water Closet Flush Tank Ball Cocks (ASSE 1002)	Gravity water closet flush tanks

(b) *Classifications.* For the purposes of this section:

1. The designation of a high hazard or low hazard situation shall be determined on the basis of how a toxic or nontoxic solution is intended or recommended by the manufacturer of the solution to interface with the potable water supply system.

2. a. A continuous pressure situation shall be considered to exist when a pressure greater than atmospheric within the water supply system exists for more than 12 continuous hours.

b. A noncontinuous pressure situation shall be considered to exist if the conditions in subd. 2. a. do not occur.

3. A high hazard cross connection situation shall be considered to exist for a connection of the water supply system to:

a. Any part of the drain system; and

b. Any other piping system conveying water from nonpotable sources, including but not limited to lakes, rivers, streams or creeks.

4. Except as provided in subd. 5., a high hazard cross connection situation shall be considered to exist at:

a. A water supply hose bibb, faucet, wall hydrant, sill cock or other outlet which terminates with hose threads allowing a hose to be attached;

b. A water supply faucet, wall hydrant or other outlet which terminates with a serrated nipple allowing a hose to be attached; and

c. A water supply faucet, hydrant or outlet serving a sink used for building maintenance in a public building.

5. A cross connection shall not be considered to exist at the hose threaded outlet installed for the sole purpose of:

a. Draining a water supply system or any portion thereof;

b. Obtaining water quality samples of the water supply system or any portion thereof; or

c. Connecting individual residential automatic clothes washers.

6. a. A high hazard situation shall be considered to exist for the connection of 2 water supply systems one supplied by a public water supply and the other system supplied by a private well.

*Note:* The interconnection of a public water supply system and another source of water is addressed in s. NR 811.09 and must be approved by the Department of Natural Resources.

b. Except as provided in subd. 7., a low hazard situation shall be considered to exist for the connection of a piping system, including but not limited to automatic fire sprinkler systems, standpipe systems, and processing purposes, which provides potable water for nonrequired potable water uses.

*Note:* Cross connection control devices used in conjunction with automatic fire sprinkler systems are to be listed by an acceptable testing agency for such an application under the standards governing the design and installation of automatic fire sprinkler systems.

7. A cross connection situation shall not be considered to exist for an automatic fire sprinkler system serving a one- or 2- family dwelling provided the sprinkler system is constructed of materials and joints suitable for water distribution systems as specified in ss. Comm 84.30 (4) (e) and 84.40, respectively and the sprinkler system is supplied with only potable water.

(c) *Containment.* 1. For sewerage treatment facilities which are required to conform with ch. NR 110, in addition to the cross connection control required for each potable water usage or water

outlet, a reduced pressure principle backflow preventer shall be installed:

a. In the water service to each building or structure within the complex;

b. In the private water main upstream of all water services serving the facility; or

c. In the water distribution system upstream of all water outlets and in the process piping network upstream of all points of use, if both a water distribution system and a process network is contained within the same building or structure.

2. For marinas, wharves and docks where potable water outlets are provided to serve boats or ships, in addition to the cross connection control required for each potable water outlet or usage, a reduced pressure principle backflow preventer shall be installed in the water supply system to limit backflow into the water supply source.

3. The installation of a cross connection control device in the water supply system for a building or structure shall not alleviate the requirement to provide cross connection control for the connection of each plumbing fixture, piece of equipment, appliance or other piping system.

(d) *Prohibitions.* The use of a toxic solution as a heat transfer fluid in single-wall heat exchanger for potable water is prohibited.

(e) *Existing automatic fire sprinkler systems.* An alteration, modification or addition to an existing automatic fire sprinkler shall necessitate conformance with this section, if the:

1. Existing water supply line to the existing sprinkler system is increased in diameter; or

2. Existing device or method which had been previously recognized to address cross connection concerns is to be removed or replaced.

(4) **LIMITATIONS.** (a) Cross connection control devices shall be limited in use in accordance with the respective standard, unless otherwise specifically permitted under this subsection.

(b) 1. Except for a deck-mounted device, a pipe applied atmospheric vacuum breaker shall be installed such that the bottom of the device or the critical level mark on the device is at least 6" above all of the following:

a. The flood level rim of the receptor serving the water supply port.

b. The highest point downstream from the device where back pressure would be created.

c. The highest point of an injection or aspiration port.

2. A deck-mounted pipe applied atmospheric type vacuum breaker shall be installed such that the bottom of the device or the critical level mark on the device is at least one inch above all of the following:

a. The flood level rim of the receptor serving the water supply port.

b. The highest point downstream from the device where back pressure would be created.

c. The highest point of an injection or aspiration port.

(c) 1. a. The use of a hose connection backflow preventer and a hose connection vacuum breaker in a continuous pressure situation shall be limited to campgrounds and marinas.

b. The use of a hose connection backflow preventer and a hose connection vacuum breaker shall be limited to the discharge side of a control valve such as a faucet or hose bibb.

2. A hose connection backflow preventer and a hose connection vacuum breaker may not be employed in backpressure situations of more than 10 feet of water column.

(d) A backflow preventer with intermediate atmospheric vent:

1. May not be employed in backpressure situations of more than 150 psig; and

2. May not serve boilers having a maximum steam pressure setting greater than 15 psig or a maximum water pressure setting greater than 30 psig.

(e) 1. A reduced pressure principle backflow preventer and a reduced pressure detector backflow preventer may not be subjected to a backpressure greater than twice the rated working pressure of the device.

2. A reduced pressure principle backflow preventer and a reduced pressure detector backflow preventer which serve a water-based fire protection system may have a test outlet located between the number 2 check valve and the number 2 listed indicating control valve.

3. A reduced pressure principle backflow preventer and a reduced pressure detector backflow preventer which are 2" or smaller in size and which serve a water-based fire protection system are not required to have a test cock on the number one listed indicating control valve.

(f) A hand-held shower may not be employed in backpressure situations of more than 2 feet of water column.

(g) 1. A double check backflow prevention assembly and a double check detector assembly backflow preventer may not be subjected to a backpressure greater than twice the rated working pressure of the device.

2. A double check backflow prevention assembly and a double check detector assembly backflow preventer which serve a water-based fire protection system may have a test outlet located between the number 2 check valve and the number 2 listed indicating control valve.

*Note:* See Appendix for further explanatory material.

3. A double check backflow prevention assembly and a double check detector assembly backflow preventer which are 2" or smaller in size and which serve a water-based fire protection system are not required to have a test cock on the number one listed indicating control valve.

(h) A water supply fed trap seal primer valve shall be installed such that the bottom of the device or the critical level as marked on the device is at least 12" above:

1. The connection to the trap; and

2. The highest point downstream from the device where back pressure would be created.

(i) A vacuum breaker wall hydrant, freeze resistant automatic draining type, may not be employed in backpressure situations of more than 10 feet of water column.

(k) 1. A pressure type vacuum breaker assembly shall be installed such that the bottom of the device or the critical level mark on the device is at least 12" above all of the following:

a. The flood level rim of the receptor serving the water supply port.

b. The highest point downstream from the device where back pressure would be created.

c. The highest point of an injection or aspiration port.

2. A pressure vacuum breaker assembly shall be located only outside.

(L) A laboratory faucet backflow preventer may not be employed in backpressure situations of more than 6 feet of water column.

(m) The cross connection control device to serve a hose bibb or hydrant that penetrates an exterior wall of a heated structure may not prevent a hose bibb or hydrant from being freeze resistant automatic draining as required under s. Comm 82.40 (8) (a).

(n) A back siphonage vacuum breaker shall be installed so that the bottom of the device or the critical level mark on the device is at least 12" above all of the following:

1. The flood level rim of the receptor serving the water supply port.

2. The highest point downstream from the device where back pressure would be created.

3. The highest point of an injection or aspiration port.

(5) **INSTALLATION.** (a) An air-gap for cross connection control shall conform to ASME A112.1.2 or ASME A112.1.3.

**Note:** See Appendix for further explanatory material.

(b) Cross connection control methods, devices and assemblies shall be installed in accordance with the manufacturer's written installation specifications and this chapter. The methods, devices and assemblies shall be accessible for inspection, testing, maintenance and replacement.

**Note:** See s. Comm 84.30 (5) (c).

(c) Cross connection control devices shall be protected from freezing.

(d) 1. A cross connection control device may not be located in uninhabitable spaces susceptible to flooding.

2. A cross connection control device which has one or more vent ports may not be located in a pit, vault or depression which is below the adjacent grade or floor level, even if the pit, vault or depression is provided with a drain at the bottom of the pit.

(e) 1. Vent ports of cross connection control devices shall be positioned:

- a. Away from areas where toxic gases and fumes may accumulate;
- b. Downward or protected to protect the ports from falling debris; and
- c. So as to drain dry.

2. Cross connection control devices shall be so located that any vent ports of the devices shall be provided with an air gap in accordance with par. (a).

3. a. If a reduced pressure principle backflow preventer or a reduced pressure detector backflow preventer is located within a building, a drain or receptor shall be provided to receive the discharge from the vent ports of the device. If a floor drain is to receive the discharge from the vent ports of a reduced pressure principle backflow preventer or a reduced pressure detector backflow preventer, the flow or pathway of the discharge may not create a nuisance.

b. Where drain piping is provided for the discharge from a vent port, an air gap in accordance with par. (a) shall be provided between the vent port and the drain piping.

c. Where a receptor is provided for the discharge from a vent port, an air gap in accordance with par. (a) shall be provided between the vent port and the receptor.

(f) The installation of a reduced pressure principle backflow preventer, a reduced pressure detector backflow preventer, a double check backflow prevention assembly, a double check detector assembly backflow preventer, a pressure vacuum breaker assembly and a back siphonage backflow vacuum breaker shall conform to the following limitations:

1. The minimum distance between the floor, surface or platform which is to provide access and the lowest point of the assembly may not be less than 12".
2. The maximum distance between the floor, surface or platform which is to provide access and the lowest point of the assembly may not be more than 7 feet.
3. The minimum distance between a ceiling or other obstruction and the highest point of the assembly may not be less than 18".
4. The minimum distance between a wall or other obstruction and the back and ends of the assembly may not be less than 4".
5. The minimum distance between a wall or other obstruction and the front of the assembly may not be less than 24".

**Note:** See Appendix for further explanatory material.

(g) The discharge outlet of local waste piping serving a cross connection control device shall be visible and not be located within a concealed space.

(h) No control valve may be placed downstream from a pipe applied atmospheric type vacuum breaker or a laboratory faucet backflow preventer.

(i) A barometric loop to provide cross connection control for backsiphonage shall be formed by creating a loop in the potable water supply piping upstream to the source of cross connection.

1. The loop shall extend at least 35 feet above:

a. The highest point downstream from the loop where back pressure would be created; and

b. The point of discharge.

2. No outlets for potable water use shall be installed downstream of the peak of the loop.

(j) Vacuum breaker tees shall be assembled such that:

1. The bottom of the horizontal portion of the tee is installed at least one inch above the flood level rim of the receptor;

2. The inside diameter of the tee is equal to or greater than the inside diameter of the drain piping from the water treatment device;

3. The tee is installed in such a position that the discharge will not create a nuisance;

4. The piping upstream of the tee is of a type suitable for water distribution in accordance with s. Comm 84.30 (4) (e).

5. The vent portion of the tee is equal to or greater than the inside diameter of the drain piping from the water treatment device; and

6. The vent port of the tee is:

a. Positioned away from areas where toxic gases and fumes may accumulate; and

b. Constructed to protect the port from falling debris.

(k) A chemical dispensing system shall be connected to the water distribution system in either of the following manners:

1. The fixture supply shall be individually connected to the water distribution system.

2. The fixture supply shall be installed with a pressure bleed ing device. The pressure bleeding device shall create a visually free flow of water through the atmosphere from the faucet connection into the fixture drain.

(6) **MAINTENANCE AND TESTING.** (a) All cross connection control devices shall be maintained and tested in accordance with s. Comm 82.21 (3).

**History:** 1-2-56; r. (2) through (7), Register, October, 1971, No. 190, eff. 11-1-71; r. and rec. Register, November, 1972, No. 203, eff. 12-1-72; renum. from H 62.14, Register, July, 1983, No. 331, eff. 8-1-83; renum. from ILHR 82.14 and am. (1) (h) 17., r. (2), Register, February, 1985, No. 350, eff. 3-1-85; r. and rec. Register, February, 1994, No. 458, eff. 3-1-94; am. (2) (a), Tables 82.41-1, 2, (4) (c), (e) to (j), (k) to (m), (5) (e) 3. a., (i), cr. (4) (n), r. and rec. (5) (b), (f), r. (5) (h), Register, February, 1997, No. 494, eff. 3-1-97; correction in (4) (n) made under s. 13.93 (2m) (b) 1., Stats., Register, February, 2000, No. 530; am. (3) (a) 2., (4) (k) 1. and (5) (a), r. and rec. (4) (b) and (n), and Tables 82.41-1 and 82.41-2, cr. (4) (k) 1. c. and (5) (L), Register, December, 2000, No. 540, eff. 1-1-01; CR 02-002: am. (3) (intro.), (5) (a), Tables 82.41-1 and 2, renum. (5) (i) to (L) to be (5) (h) to (k) Register April 2003 No. 568, eff. 5-1-03.

## Subchapter V — Special Plumbing Installations

### Comm 82.50 Health care and related facilities.

(1) **GENERAL.** The provisions of this section shall set forth the requirements for the design, installation and maintenance of devices, fixtures and equipment which are installed in health care and related facilities.

(2) **FIXTURES AND EQUIPMENT.** (a) *Special fixtures and equipment.* 1. 'Requirements for ice manufacture and storage.' Machines for manufacturing ice or any device for handling or storage of ice shall be located in an area not subject to contamination.

2. 'Sterilizers and washer sanitizers.' a. Sterilizers and washer sanitizers shall discharge by means of indirect waste.

b. The indirect waste piping shall discharge by means of air-gap.

3. 'Aspirators.' Aspirators which require the use of water shall be provided with approved cross connection control.

(b) *Spouts and actions.* The selection of spouts and actions on plumbing fixtures shall comply with this section and Table 82.50-1.

1. 'Spouts'. Lavatories and sinks accessible to patients shall have the water supply spout mounted so that its discharge point is a minimum distance of 5" above the flood level rim of the fixture.

2. 'Actions.' All fixtures used by medical and nursing staff, and all lavatories used by patients and food handlers shall be equipped with valves that can be operated without the use of hands. Where wrist blade handles are used for this purpose, the handles shall not exceed 4 1/2" in length, except handles on scrub sinks and clinical sinks shall be no less than 6" long.

(c) *Floor drain prohibition.* 1. Except as provided in subd. 2., floor drains may not be installed in operating or delivery rooms.

2. Floor drains may be installed in cystoscopic rooms. The drain shall contain a non-splash, horizontal-flow flushing bowl beneath the drain plate.

(3) **WATER SUPPLY SYSTEMS.** (a) *Hospital water supply systems.* Water supply systems serving hospitals shall comply with all of the following:

1. All hospitals shall be provided with at least 2 water services. Whenever more than one water main is available, the connections shall be made to different water mains.

2. Each water service connection shall adequately serve the total building water supply demand as specified in s. Comm 82.40 (7).

**Note:** The installation of two water services or a private water main may require the installation of a check valve. Refer to ch. NR 811 for more information.

(b) *Hospital, community-based residential facility, inpatient hospice and nursing home water supply systems.* 1. Water supply systems serving a hospital, community-based residential facility, inpatient hospice or nursing home shall comply with all of the following:

a. Except as provided in subd. 1. b., a single control valve may serve an area where 4 or fewer patient care units exist and where each unit contains not more than 2 persons.

b. A water supply serving an intensive care patient care unit shall be individually valved.

2. All water distribution piping shall be insulated in accordance with chs. Comm 61 to 65.

3. Cold water shall be supplied to lavatories or sinks located in patient rooms.

4. A hot water distribution system shall be under constant recirculation to provide continuous hot water at each hot water outlet, except that uncirculated hot water distribution piping may not exceed 25 feet in developed length.

5. Water provided to patient showers, therapeutic equipment and all types of baths shall be installed with control valves which automatically regulate the temperature of the water supply to the fixture fitting outlet within a temperature range of 110°F to 115°F. Such control valves shall automatically reduce flow to 0.25 gpm or less when the water supply to the fitting outlet exceeds 115°F.

**Note:** See Appendix A-82.50 (3) (b) 5. for sketches showing various design options.

6. Hot water distribution systems shall be installed and maintained to provide bacterial control by one of the following methods:

a. Water stored and circulation initiated at a minimum of 140°F and with a return of a minimum of 124°F.

b. Water chlorinated at 2 mg/L residual.

**Note:** Additional information may be contained in ASHRAE Guideline 12-2000, Minimizing the Risk of Legionellosis Associated with Building Water Systems. This standard is published by the American Society of Heating, Refrigerating and Air-Conditioning Engineers (ASHRAE); 1791 Tullie Circle, N.E., Atlanta, GA 30329, phone: (800) 5-ASHRAE or (404) 636-8400 ext. 507; fax: (404) 321-5478; e-mail: orders@ashrae.org; or online at www.ashrae.org.

c. Another disinfection system approved by the department.

7. A water distribution system may not be designed, installed and maintained so that the maximum temperature to fixture fitting outlets accessible to patients exceeds 115°F.

**Note:** See s. Comm 82.40 (5) and ch. HFS 124 for additional requirements for circulation systems.

8. Except as provided in subd. 7., a water distribution system may not be designed, installed and maintained so that the maximum temperature to fixture fitting outlets exceeds 180°F.

**TABLE 82.50-1**  
**SPOUTS AND ACTIONS REQUIRED IN HEALTH CARE AND RELATED FACILITIES**

Fixture Location	Type of Spout		Type of Action		
	Standard	Gooseneck or provide a 5-inch clearance	Hand	Wrist	Foot, Knee or Electronic Sensor
<b>NURSING DEPARTMENT</b>					
Patient toilet room		X		X	X
Patient toilet room, isolation		X			X
Utility room		X		X	X
Treatment room		X		X	X
Medicine room		X		X	X
Kitchen floor lavatory		X		X	X
Kitchen floor sink	X	X		X	X
Nurses toilet room	X	X	X	X	X
Floor laboratory		X	X	X	X
<b>NURSERY</b>					
Nursery		X		X	X
Exam/treatment room		X		X	X
Infant intensive care unit		X			X
Labor room		X		X	X
<b>SURGICAL</b>					
Scrub room		X <sup>a</sup>			X
Sub-sterile room	X	X		X	X

**TABLE 82.50-1 (Continued)**  
**SPOUTS AND ACTIONS REQUIRED IN HEALTH CARE AND RELATED FACILITIES**

Fixture Location	Type of Spout		Type of Action		
	Standard	Gooseneck or provide a 5-inch clearance	Hand	Wrist	Foot, Knee or Electronic Sensor
Clean-up room	X	X		X	X
Frozen sections room		X	X	X	X
Surgical supply room		X		X	X
Work room	X	X		X	X
Cystoscopic room		X <sup>a</sup>		X	X
Fracture room	X	X		X	X
Recovery room		X			X
<b>CENTRAL SUPPLY</b>					
Work room	X	X		X	X
Solutions room	X	X		X	X
Pharmacy		X	X	X	X
Manufacturing		X		X	X
<b>EMERGENCY DEPARTMENT</b>					
Observation bedroom		X		X	X
Utility room		X		X	X
Operating room		X <sup>a</sup>			X
Exam room		X		X	X
<b>DIAGNOSTIC AND TREATMENT</b>					
Occupational therapy room		X		X	X
Hydro-therapy room		X		X	X
Exam/treatment room		X		X	X
Radium treatment/exam room		X		X	X
Toilet room		X		X	X
Dark room		X		X	X
Autopsy room		X <sup>a</sup>			X
Lavatory in autopsy shower room		X	X		X
Laboratory		X	X		X
<b>CLINIC OR OUTPATIENT DEPARTMENT</b>					
Exam/treatment room		X		X	X
Dental operating room		X			X
Dental laboratory		X	X	X	X
Dental recovery room		X		X	X
Surgical room		X <sup>a</sup>			X
Eye exam room		X			X
Ear, nose and throat exam room		X			X
<b>SERVICE DEPARTMENT</b>					
Lavatory in kitchen	X	X		X	X

X = Spout and action meet required type.

<sup>a</sup> Spout includes a spray head.

**History:** 1-2-56; am. (3) (4) and (5), Register, August, 1961, No. 68, eff. 9-1-61; r. and recr. Register, November, 1972, No. 203, eff. 12-1-72; r. and recr., Register, February, 1979, No. 278, eff. 3-1-79; renum. from H 62.16, Register, July, 1983, No. 331, eff. 8-1-83; renum. from ILHR 82.16 and am. (7) (b), (10) (a) 1. and 2., (b) 2., (f) (intro.) and (h), Register, February, 1985, No. 350, eff. 3-1-85; r. (10) (f) and Table 25, Register, February, 1994, No. 458, eff. 3-1-94; correction in (7) (b) made under s. 13.93 (2m) (b) 7., Stats., Register, July, 2000, No. 535; am. (2) and (10) (g) Table 26, r. and recr. (10) (g) and (h), r. (10) (i), Register, December, 2000, No. 540, eff. 1-1-01; CR 02-002: r. and recr. Register April 2003 No. 568, eff. 5-1-03.



**Comm 82.51 Mobile homes and mobile home parks.**

**(1) DRAIN SYSTEMS.** Except as provided in pars. (a) and (b), the building sewers and private interceptor main sewers serving a mobile home or mobile home park shall comply with s. Comm 82.30.

(a) The minimum slope of the aboveground building sewer shall be 1/8" per foot.

(b) For mobile homes, the most upstream point of the building sewer shall be determined at the connection with the building drain installed by the mobile home manufacturer prior to delivery.

(c) The above ground building sewer shall be constructed of materials suitable for above ground drain and vent as specified in s. Comm 84.30 (2) (a).

**(2) WATER SUPPLY SYSTEMS.** (a) Except as provided in pars. (b) and (c), the water services and private water mains for a mobile home or mobile home park shall comply with s. Comm 82.40.

(b) The above ground water service shall be constructed of materials approved for water distribution as specified in s. Comm 84.30 (4) (e).

(c) The curb stop serving an individual mobile home shall terminate outside the perimeter of the mobile home.

(d) For mobile homes, the most downstream point of the water service shall be determined at the connection with the water distribution piping by the mobile home manufacturer prior to delivery.

**(3) MOBILE HOME CONNECTIONS.** (a) Frost sleeves for plumbing serving a mobile home shall conform to all of the following:

1. Water service and building sewer connections shall be provided with frost sleeves extending to within 6" of the top of the below ground horizontal building sewer or water service, or to a depth at least 6" below the predicted depth of frost in accordance with Table 82.30-6.

2. The frost sleeve shall terminate at least 2" above grade.

3. The sleeve shall be constructed of material approved for building drain or building sewer material as specified in s. Comm 84.30 (2).

(b) Termination of the water service and building sewer shall conform to all of the following:

1. The mobile home water service for connection to the mobile home shall terminate a minimum of 6" above the surrounding finished grade.

2. The mobile home building sewer for connection to the mobile home shall terminate a minimum of 4" above the surrounding finished grade and may not terminate higher than the water service.

(c) The mobile home water service and building sewer shall be capped or plugged when not connected to a mobile home.

**History:** Cr. Register, February, 1985, No. 350, eff. 3-1-85; r. and recr. Table, Register, August, 1991, No. 428, eff. 9-1-91; am. (2) (d), Register, February, 1994, No. 458, eff. 3-1-94; CR 02-002: r. and recr. Register April 2003 No. 568, eff. 5-1-03.

**Subchapter VI — Installation**

**Comm 82.60 Pipe hangers and supports.** The provisions of this section control the types, materials and installation of anchors, hangers and supports for plumbing piping.

**(1) MATERIAL.** (a) *Strength.* Hangers, anchors and supports for piping shall be of sufficient strength to support the piping and its contents. Drain piping shall be considered as being full of water. Underground piers for pipe support shall be of concrete, masonry, plastic or pressure treated wood.

(b) *Compatibility.* 1. Hangers and straps shall be of a compatible material that will reduce the potential for galvanic action with the piping.

2. Hangers and straps may not distort, cut or abrade piping.

**(2) INSTALLATION.** (a) Piping hangers and anchors shall be securely attached to the building's structure at intervals to support

the piping and its contents, but not at intervals greater than those specified in Table 82.60. The connection of drain piping to a fixture or appliance shall be considered a point of support.

(b) Hubless pipe installed in the horizontal position shall be supported within 24" on each side of a joint, unless the joint has an alignment retaining shield.

(c) Hangers shall not be attached to a building's structure by means of wood plugs.

(d) Shower valves and piping from the shower valve to the shower head outlet shall be securely attached to the structure.

**Table 82.60  
SUPPORT SPACING**

Material	Maximum Horizontal Spacing (feet)	Maximum Vertical Spacing (feet)
Acrylonitrile Butadiene Styrene (ABS)	4	10
Brass	10	10
Cast iron	5 <sup>a</sup>	15
Copper or Copper-Alloy Pipe	12	10
Copper or Copper-Alloy Tubing:		
≤ 1¼" diameter <sup>c</sup>	6	10
≥ 1½" diameter <sup>c</sup>	10	10
Chlorinated Polyvinyl Chloride (CPVC):		
≤ 1" diameter <sup>c</sup>	3	5 <sup>b</sup>
≥ 1¼" diameter <sup>c</sup>	4	6 <sup>b</sup>
Crosslinked Polyethylene (PEX)	2 2/3	4
Ductile Iron	5 <sup>a</sup>	15
Galvanized Steel	12	15
Lead	Continuous	4
Polybutylene (PB)	2 ft. 8 in.	4
Polyethylene (PE)	2	4
Polypropylene (PP)	2	4
Polyvinylidene Fluoride (PVDF)	2	4
Polyvinyl Chloride, flexible (PVC)	2	4
Polyvinyl Chloride (PVC)	4	10
Stainless Steel	12	15

<sup>a</sup> The maximum horizontal spacing for supports may be increased to 10 feet when 10-foot lengths of pipe are employed.

<sup>b</sup> Mid-story guide is to be employed.

<sup>c</sup> "≥" means greater than or equal to.

"≤" means less than or equal to.

**History:** Cr. Register, February, 1985, No. 350, eff. 3-1-85; r. and recr. Register, May, 1988, No. 389, eff. 6-1-88; r. and recr. Table 82.60, Register, February, 1994, No. 458, eff. 3-1-94; cr. (2) (d), Register, December, 2000, No. 540, eff. 1-1-01; CR 02-002: am. Table Register April 2003 No. 568, eff. 5-1-03.

**Subchapter VII — Plumbing Treatment Standards****Comm 82.70 Plumbing treatment standards.**

**(1) PURPOSE.** The purpose of this section is to establish plumbing treatment standards for plumbing systems that supply water to outlets based on the intended use.

**(2) SCOPE.** The provisions of this section apply to plumbing systems that supply water to outlets.

Note: For requirements and specifications for POWTS, refer to ch. Comm 83.

Note: The department of natural resources requires WPDES permits for point source discharges under ch. 283, Stats.

(3) GENERAL REQUIREMENTS. A plumbing system shall supply water that is of a quality that will protect public health and the waters of the state and be suitable for the intended use.

Note: Refer to s. Comm 82.34 for requirements for wastewater reuse.

(4) MINIMUM REQUIREMENTS. (a) Except as provided under par. (b), a plumbing system shall supply a quality of water at the outlet or at the termination of the plumbing system that meets or exceeds the minimum requirements as specified in Table 82.70-1.

(b) For an outlet other than a plumbing fixture, appliance or appurtenance, there may be more stringent requirements assigned by a municipality, governmental unit, state agency or the owner of the plumbing system.

**Table 82.70-1  
PLUMBING TREATMENT STANDARDS**

Intended Use	Plumbing Treatment Standards
1. Drinking, cooking, food processing, preparation and cleaning, pharmaceutical processing, and medical uses	NR 811 and 812 approved sources
2. Personal hygiene, bathing, and showering, clothes washing, etc.	NR 811 and 812 approved sources
3. Automatic fire protection systems	As acceptable by local authority
4. Swimming pool makeup water	NR 811 and 812 approved sources to private water supplies
5. Swimming pool fill	Pool fill requirements in accordance with ch. HFS 172
6. Once through cooling	pH 6 - 9 <sup>c</sup> ≤ 30 mg/L BOD <sub>5</sub> ≤ 30 mg/L TSS ≤ 200 fecal coliform/100 mL ≥ 1 mg/L chlorine residual <sup>c</sup>

7. Subsurface dispersal/irrigation <sup>b, d, e</sup>	≤ 30 mg/L oil and grease ≤ 30 mg/L BOD <sub>5</sub> ≤ 150 mg/L TSS ≤ 200 fecal coliform/100 mL
8. Surface or spray irrigation of any food crop, including crops eaten raw, non-commercial only <sup>a, e</sup>	pH 6 - 9 <sup>c</sup> ≤ 10 mg/L BOD <sub>5</sub> ≤ 5 mg/L TSS no detectable fecal coliform/100 mL ≥ 1 mg/L chlorine residual <sup>c</sup>
9. Surface irrigation, vehicle washing, toilet and urinal flushing, air conditioning and other urban uses with similar human access or exposure to the water <sup>d, e</sup>	pH 6 - 9 <sup>c</sup> ≤ 10 mg/L BOD <sub>5</sub> ≤ 5 mg/L TSS no detectable fecal coliform/100 mL ≥ 1 mg/L chlorine residual <sup>c</sup>
10. Soil compaction, dust control, washing aggregate and making concrete	≤ 30 mg/L BOD <sub>5</sub> ≤ 30 mg/L TSS ≤ 200 fecal coliform/100 mL ≥ 1 mg/L chlorine residual <sup>c</sup>
11. Irrigation of sod farms, silviculture sites and other areas where human access is prohibited or restricted <sup>e</sup>	pH 6 - 9 <sup>c</sup> ≤ 30 mg/L BOD <sub>5</sub> ≤ 30 mg/L TSS ≤ 200 fecal coliform/100 mL ≥ 1 mg/L chlorine residual <sup>c</sup>
12. Uses not specifically listed above	Contact department for approval

<sup>a</sup> Refer to the department of agriculture, trade and consumer protection for commercial use.

<sup>b</sup> Refer to ch. Comm 83 for domestic wastewater treatment requirements.

<sup>c</sup> Applies only to wastewater treatment devices for reuse systems. Other equivalent disinfection methods may be approved by the department.

<sup>d</sup> Stormwater collected from parking lots and industrial sites may not be infiltrated prior to pretreatment.

<sup>e</sup> These requirements do not apply to the treatment of industrial wastewater or other wastewater discharges that are subject to a WPDES permit issued by the department of natural resources.

History: CR 02-002; cr. Register April 2003 No. 568, eff. 5-1-03.

## Chapter Comm 83

### PRIVATE ONSITE WASTEWATER TREATMENT SYSTEMS

#### Subchapter I — Scope and Application

- Comm 83.01 Purpose.
- Comm 83.02 Scope.
- Comm 83.03 Application.
- Comm 83.04 Implementation.
- Comm 83.05 Installation and inspection training.

#### Subchapter II — Administration and Enforcement

- Comm 83.20 Purpose.
- Comm 83.21 Sanitary permits.
- Comm 83.22 Plan review and approval.
- Comm 83.23 Review agent status.
- Comm 83.24 Petitions for variance.
- Comm 83.25 Governmental programs.
- Comm 83.26 Inspections and testing.
- Comm 83.27 Experiments.
- Comm 83.28 Penalties.
- Comm 83.29 Range of responses.

#### Subchapter III — General Requirements

- Comm 83.30 Purpose.
- Comm 83.31 Principles.
- Comm 83.32 Prohibitions and limitations.
- Comm 83.33 Abandonment.

#### Subchapter IV — Design and Installation

- Comm 83.40 Purpose.
- Comm 83.41 Principles.
- Comm 83.42 Application.
- Comm 83.43 General requirements.
- Comm 83.44 Parameters for POWTS components consisting of in situ soil.
- Comm 83.45 Installation.

#### Subchapter V — Management

- Comm 83.50 Purpose.
- Comm 83.51 Principles.
- Comm 83.52 Responsibilities.
- Comm 83.53 General.
- Comm 83.54 Management requirements.
- Comm 83.55 Reporting requirements.

#### Subchapter VI — Recognized Methods and Technologies

- Comm 83.60 Purpose.
- Comm 83.61 Acceptable methods and technologies.
- Comm 83.62 Parameters for using acceptable methods and technologies.

#### Subchapter VII — Department Performance Monitoring

- Comm 83.70 Purpose.
- Comm 83.71 Department procedures.

**Note:** Chapter H 63 was created as an emergency rule effective 6-21-80; section H 62.20 as it existed on June 30, 1983 was renumbered to chapter ILHR 83. Chapter ILHR 83 was renumbered chapter Comm 83 under s. 13.93 (2m) (b) 1., Stats., and corrections made under s. 13.93 (2m) (b) 6. and 7., Stats., Register, February, 1997, No. 494. Chapter Comm 83 as it existed on June 30, 2000 was repealed and a new chapter Comm 83 was created, Register, April, 2000, No. 532, eff. 7-1-00.

#### Subchapter I — Scope and Application

**Comm 83.01 Purpose.** The purpose of this chapter is to establish uniform standards and criteria for the design, installation, inspection and management of a private onsite wastewater treatment system, POWTS, so that the system is safe and will protect public health and the waters of the state.

**History:** Cr. Register, April, 2000, No. 532, eff. 7-1-00; CR 02-129; am. Register January 2004 No. 577, eff. 2-1-04.

**Comm 83.02 Scope.** (1) WASTEWATER GENERATION. Except as delineated in sub. (2), this chapter applies to all of the following:

(a) A situation where domestic wastewater is collected and conducted by means of plumbing drain systems and is not conveyed to a wastewater treatment facility regulated by the department of natural resources.

(b) A POWTS where domestic wastewater is treated and dispersed to the subsurface.

(c) A holding tank that is utilized as a POWTS or as part of a POWTS to collect and hold domestic wastewater for transport and treatment elsewhere.

**Note:** Section Comm 82.10 (8) states that where plumbing fixtures exist in a building which is not connected to a public sewer system, suitable provision shall be made for treating and recycling the sewage and wastewater by a method of holding or treatment and dispersal satisfactory to the department.

**Note:** The department of natural resources is responsible for establishing, administering and enforcing standards relative to domestic wastewater treatment systems which either disperse to the surface or to surface waters. The department of natural resources also establishes effluent limitations and monitoring requirements where the design daily influent wastewater flow to a POWTS exceeds 12,000 gallons per day for the purpose of fulfilling WPDES permit requirements under ch. 283, Stats.

**Note:** Pursuant to s. 281.17 (5), Stats., the department of natural resources may also restrict or specify the type of wastewater treatment necessary. Section 281.17 (5) reads:

*The department [department of natural resources] may prohibit the installation or use of septic tanks in any area of the state where the department finds that the use of septic tanks would impair water quality. The department shall prescribe alternate methods for waste treatment and disposal in such prohibited areas.*

(2) EXEMPTIONS. This chapter does not apply to:

(a) A POWTS owned by the federal government and located on federal lands; and

(b) A POWTS located or to be located on land held in trust by the federal government for Native Americans.

(3) SUBDIVISION STANDARDS. This chapter does not establish minimum lot sizes or lot elevations under s. 145.23, Stats., for the purpose of the department reviewing proposed subdivisions which will not be served by public sewers under s. 236.12, Stats.

**History:** Cr. Register, April, 2000, No. 532, eff. 7-1-00.

**Comm 83.03 Application.** (1) INSTALLATIONS. (a) *New POWTS installations.* The design, installation and management of a new POWTS shall conform with this chapter.

**Note:** Pursuant to s. 145.135 (2) (b), Stats., the approval of a sanitary permit is based on the rules in effect on the date of the permit approval.

(b) *Modifications to existing POWTS.* A modification to an existing POWTS, including the replacement, alteration or addition of materials, appurtenances or POWTS components, shall require that the modification conform to this chapter.

**Note:** The modification of one part of a POWTS may affect the performance or the operation of other parts of the POWTS thereby necessitating further modifications for the 'other parts' to be or remain compliant with the appropriate edition of the state plumbing code; see sub. (2) (b) 1.

(c) *Modifications to existing structures served by existing POWTS.* When an addition or alteration is proposed to an existing building, structure or facility that is served by an existing POWTS and the proposed addition or alteration will result in a change that affects the wastewater flow or wastewater contaminant load beyond the minimum or maximum capabilities of the existing POWTS, the POWTS shall be modified to conform to the rules of this chapter.

**Note:** See s. Comm 83.25 (2) relating to the issuance of building permits.

(2) RETROACTIVITY. (a) This chapter does not apply retroactively to an existing POWTS installed prior to July 1, 2000, or for which a sanitary permit has been issued prior to July 1, 2000, except as provided in ss. Comm 83.32 (1) (a) and (c) to (g), 83.54 (4) and 83.55 (1) (b).

(b) 1. Except as provided in subd. 2. and ss. Comm 83.32 (1) (a) and (c) to (g), 83.54 (4) and 83.55 (1) (b), an existing POWTS installed prior to July 1, 2000, shall conform to the siting, design, construction and maintenance rules in effect at the time the sanitary permit was obtained or at the time of installation, if no permit was issued.

2. a. An existing POWTS installed prior to December 1, 1969 with an infiltrative surface of a treatment and dispersal component that is located 2 feet or more above groundwater or bedrock shall be considered to discharge final effluent that is not sewage, unless proven otherwise.

b. An existing POWTS installed prior to December 1, 1969 with an infiltrative surface of a treatment and dispersal component that is located less than 2 feet above groundwater or bedrock shall be considered to discharge final effluent that is sewage, unless proven otherwise.

(c) An existing POWTS which conforms with this chapter shall be permitted to remain as installed.

**(3) PLAT RESTRICTIONS.** The department shall consider a restriction or a prohibition placed on a lot or an outlet prior to July 1, 2000, as a result of its plat review authority under s. 236.12, Stats., waived, if a POWTS proposed for the lot complies with this chapter.

**Note:** The waiving of a restriction or prohibition placed on a lot or outlet by the department is a review action. Pursuant to s. Comm 2.635, a fee is needed to initiate the review action.

**Note:** Under the provisions of ch. 236, Stats., the department of administration and local municipalities have review authority over lots in subdivisions not served by public sewers. A written release of a restriction or prohibition may be required by the department of administration and local municipality. A Correction Instrument may be required under the provisions of s. 236.295, Stats.

**(4) GROUNDWATER STANDARDS.** (a) Pursuant to s. 160.255, Stats., the design, installation, use or maintenance of a POWTS is not required to comply with the nitrate standard specified in ch. NR 140 Table 1, except as provided under sub. (5).

(b) Pursuant to s. 160.19 (2) (a), Stats., the department has determined that it is not technically or economically feasible to require that a POWTS treat wastewater to comply with the preventative action limit for chloride specified in ch. NR 140 Table 2 as existed on June 1, 1998.

**Note:** The prevention action limit for chloride as a performance standard relative to the design and management of a POWTS has been determined to be unfeasible because anion exchange is the only chemical process capable of removing chloride from water. The physical processes of removing chloride, such as through evaporation and reverse osmosis, would separate feedwater into two streams, one with a reduced chloride content and the other with an increased chloride content, and result in still having to treat and dispose of chloride contaminated wastewater. The design and management practice to address the enforcement standard for chloride as it relates to a POWTS is addressed under s. Comm 82.40 (8) (j).

**(5) LOCAL ORDINANCES.** Pursuant to ss. 59.70 (5) (a), 145.02 (2) and 145.13, Stats., this chapter is uniform in application and a governmental unit may not enact an ordinance for the design, installation, inspection and management of a POWTS which is more or less stringent than this chapter, except as specifically permitted by rule.

**Note:** Pursuant to ss. 59.69, 60.62, 61.35 and 62.23, Stats., this chapter does not affect municipal authority for zoning, including establishing nitrate standards as part of a zoning ordinance to encourage the protection of groundwater resources.

**History:** Cr. Register, April, 2000, No. 532, eff. 7-1-00; CR 02-129: am. (2) (b) 1., r. and recr. (5) Register January 2004 No. 577, eff. 2-1-04.

**Comm 83.04 Implementation. (1)** (a) For the purpose of facilitating inspection responsibilities and services, a governmental unit may not issue a sanitary permit for the construction or use of a POWTS that utilizes any of the technologies, designs or methods delineated in Table 83.04-1 and that has been recognized under s. Comm 84.10 (3) or 83.22, unless the governmental unit utilizes one or more individuals, who have obtained approved training under s. Comm 83.05 for the POWTS technology, design or method, to provide the inspections under s. Comm 83.26 (2) to (4), except as provided in par. (b).

(b) A governmental unit may issue a sanitary permit for the construction or use of a POWTS that utilizes any of the technologies, designs or methods delineated in Table 83.04-1 and that has not been recognized under s. Comm 84.10 (3), but has been approved by the department under s. Comm 83.22, provided that governmental unit has arranged with the department to provide the inspections under s. Comm 83.26 (2) to (4).

**Table 83.04-1**  
**Restricted Technologies**

Technology	
1.	Pressurized distribution component with less than 1/8 inch orifice diameter. <sup>a</sup>
2.	Mechanical POWTS treatment component. <sup>b</sup>
3.	Disinfection unit. <sup>c</sup>
4.	Sand, gravel or peat filter as a POWTS treatment component. <sup>d</sup>

<sup>a</sup> Includes drip distribution.

<sup>b</sup> Includes an aerobic treatment tank or a complete treatment unit within a tank.

<sup>c</sup> Includes a chlorinator, ozonation unit, and ultraviolet light unit.

<sup>d</sup> Does not include a mound system.

**(2)** (a) For the purpose of facilitating planning and administration, a governmental unit may, by ordinance, allot, limit or deny the issuance of sanitary permits within the jurisdiction of the governmental unit for the construction or use of POWTS designs that utilize a method or technology that is added to the list under s. Comm 83.61 after July 1, 2001 for not more than 18 months after that type of method or technology has been recognized under that section.

(b) 1. The governmental unit option to allot, limit or deny the issuance of sanitary permits under par. (a) shall be limited to permits intended to serve new development.

2. For the purpose of this subsection, a new development shall be considered a property without an existing habitable building.

**Note:** The provisions of this section relating to a governmental unit's ability to limit the issuance of sanitary permits for new development does not dictate a specific strategy as to the scope of the limitation. Therefore, limitation options include, but are not limited to, a prohibition for all new development or in certain geographical areas, a quota system for new development, a requirement for a permit to operate for a specific POWTS method or technology, or a service/performance bond for a specific POWTS method or technology.

**History:** Cr. Register, April, 2000, No. 532, eff. 7-1-00; CR 02-129: am. Table 83.04-1 footnote <sup>a</sup>, r. (2) and Table 83.04-2, renum. (3) to be (2) Register January 2004 No. 577, eff. 2-1-04.

**Comm 83.05 Installation and inspection training.**

**(1) PROGRAM SPECIFICATIONS.** (a) Only courses, programs and seminars approved in writing by the department in accordance with this section shall be used to fulfill the required training for the POWTS technologies and methods under ss. Comm 83.04 (1) (a) and 83.21 (2) (c) 4.

(b) 1. The request for a course, program or seminar to be recognized for approval shall be submitted in writing to the department.

2. The request for a course, program or seminar to be recognized for approval shall be received by the department at least 30 calendar days prior to the first day the course, program or seminar is to be conducted.

3. The request for approval shall include sufficient information to determine if the course, program or seminar complies with this subsection.

4. The department shall review and make a determination on a request for approval within 21 calendar days of receipt of the request and information necessary to complete the review.

(c) Courses, programs and seminars to be considered for approval toward installation and inspection training credit shall relate to the installation, operation and maintenance of the technology or method.

(d) 1. The department may impose specific conditions in approving a course, program or seminar for installation and inspection training credit, including limiting credit to specific license, certification or registration categories.

2. The approval of a course, program or seminar for installation and inspection training credit shall expire 5 years after the date of approval.

3. The department may revoke the approval of a course, program or seminar for installation and inspection credit for any false statements, misrepresentation of facts or violation of the conditions on which the approval was based. The department may not revoke the approval of a course, program or seminar less than 30 calendar days prior to the course, program or seminar being held.

(e) 1. The individual or organization that had obtained the course, program or seminar approval shall maintain an attendance record of those individuals who have attended and completed the course, program or seminar.

2. The attendance record shall include all of the following:

- a. The course name.
- b. The course identification number assigned by the department.
- c. The date or dates the course was held or completed.
- d. The name of each person attending the course for training and inspection credit.

3. A copy of the attendance record shall be forwarded by the person or organization that had obtained the course, program or seminar approval to the department within 14 calendar days after completion of the course, program or seminar.

(2) **EVIDENCE OF COMPLIANCE.** An individual who has completed the installation and inspection training shall be responsible for retaining evidence of achieving the training in order to fulfill the obligations under ss. Comm 83.04 (1) (a) and 83.21 (2) (c) 4.

History: Cr. Register, April, 2000, No. 532, eff. 7-1-00.

## Subchapter II — Administration and Enforcement

**Comm 83.20 Purpose.** (1) This subchapter establishes the following:

(a) Regulatory processes and procedures which are to be followed when designing, installing or maintaining a POWTS; and

(b) Responsibilities and actions of the various governmental agencies involved with the administration and enforcement of this chapter

Note: Section 145.20 (1) (a), Stats., states that the governing body of the governmental unit responsible for the regulation of private sewage systems may assign the duties of administering the private sewage system program to any office, department, committee, board, commission, position or employee of that governmental unit.

(2) Nothing in this chapter shall limit the authority and power of a governmental unit in exercising administration and enforcement responsibilities regarding a POWTS, including requiring and issuing other types of permits for activities not covered under this subchapter relating to sanitary permits.

History: Cr. Register, April, 2000, No. 532, eff. 7-1-00.

**Comm 83.21 Sanitary permits.** (1) **GENERAL.** (a) Pursuant to ss. 145.135 and 145.19, Stats., the installation or construction of a POWTS may not commence or continue unless all of the following have been fulfilled:

1. The owner of the property on which the POWTS is to be installed possesses a valid sanitary permit.

2. Plan approval for the POWTS has been obtained in accordance with s. Comm 83.22.

(b) The modification of an existing POWTS may not commence or continue unless the owner of the property on which the POWTS is located possesses a valid sanitary permit and has obtained plan approval for the modification under s. Comm 83.22, if the modification involves the addition or replacement of any of the following:

1. A POWTS holding component.
2. A POWTS treatment component.
3. A POWTS dispersal component.

(2) **APPLICATION.** (a) The application for a sanitary permit shall be made in a format prescribed by the department.

Note: An application for a sanitary permit may be obtained from the governmental unit administering and enforcing this chapter or the department. See appendix for

further information relative to the application format and addresses of governmental units and the department.

(b) 1. Except as provided in subd. 2., the application for a sanitary permit shall be submitted to the appropriate governmental unit where the POWTS is located or will be located.

2. The application for a sanitary permit shall be submitted to the department for a POWTS that is located or will be located on property owned by the state.

Note: Section 145.20 (2) (b), Stats., states that the governmental unit responsible for regulation of private sewage systems shall approve or disapprove applications for sanitary permits and assist applicants in preparing an approvable application.

(c) The application for a sanitary permit to the governmental unit shall be accompanied by all of the following:

1. At least one set of clear and legible plans and specifications delineating the information under s. Comm 83.22 (2) (a) 3. and (c).

2. A set of plans bearing the department's conditional approval and the approval letter issued by the department, if required to be reviewed by the department under s. Comm 83.22 (1).

3. Sufficient supporting information to determine whether the proposed design, installation and management of the POWTS or the proposed modification to an existing POWTS conforms with this chapter.

4. Documentation that the master plumber or the master plumber-restricted who is to be responsible for the installation or modification of the POWTS has completed approved training or has documentation that approved training will be provided during the installation of the POWTS, if the application for the sanitary permit involves one or more of the technologies or methods specified in s. Comm 83.04 (1).

5. Documentation that maintenance requirements for the proposed POWTS technology or method have been recorded with the deed for the property, if the management plan for the installation or modification under s. Comm 83.54 (1) involves one or more of the following:

a. Evaluating or monitoring any part of the system at an interval of 12 months or less.

b. Servicing or maintaining any part of the system at an interval of 12 months or less.

6. Any other information as specified by local ordinance relating to POWTS installations.

7. A fee as specified by the governmental unit.

Note: Section 145.19 (2) to (6) reads:

"(2) **FEE.** No fee for a sanitary permit may be less than \$61, or the amount determined under department rule. The governing body for the governmental unit responsible for the regulation of private sewage systems may establish a fee for a sanitary permit which is more than \$61, or the amount determined under department rule. [Pursuant to s. Comm 2.67 (1), the minimum sanitary permit fee is \$116.]

(3) **COPY OF PERMIT FORWARDED TO THE DEPARTMENT.** The governmental unit responsible for the regulation of private sewage systems shall forward a copy of each valid sanitary permit and \$20, or the amount determined under department rule, of the fee to the department within 90 days after the permit is issued. [Pursuant to s. Comm 2.67 (2), \$50 of the sanitary permit fee is to be forwarded to the department.]

(4) **USE OF FEE.** The portion of this fee retained by the governmental unit responsible for the regulation of private sewage systems shall be used for the administration of private sewage system programs.

(5) **FEE ADJUSTMENT.** The department, by rule promulgated under ch. 227, may adjust the minimum permit fee under sub. (2) and the fee portion forwarded under sub. (3).

(6) **GROUNDWATER FEE.** In addition to the fee under sub. (2), the governmental unit responsible for the regulation of private sewage systems shall collect a groundwater fee of \$25 for each sanitary permit. The governmental unit shall forward this fee to the department together with the copy of the sanitary permit and the fee under sub. (3). The moneys collected under this subsection shall be credited to the environmental fund for environmental management."

(3) **PROCESSING.** (a) A sanitary permit may not be issued until the plans and specifications have been approved by the department or governmental unit having jurisdiction.

(b) A governmental unit may not issue a sanitary permit for the installation or modification of the POWTS that involves one or more of the technologies or methods specified in s. Comm 83.04 (1) unless the master plumber or the master plumber-restricted

who is to be responsible for the installation or modification has completed approved training or has documentation that approved training will be provided during the installation of the POWTS.

(c) A governmental unit shall review and make a determination on the submission of an application for a sanitary permit within 30 days after receiving all the required information and fees under sub. (2) (c).

(d) 1. If upon review of the application and the supporting information, the governmental unit or the department determines that the proposed design, installation and management of the POWTS or the proposed modification of an existing POWTS conforms with this chapter, a sanitary permit shall be issued.

2. a. If upon review of the application and the supporting information, the governmental unit or the department determines that the proposed design, installation and management of the POWTS or the proposed modification of an existing POWTS does not conform with this chapter, a sanitary permit may not be issued.

b. When the issuance of a sanitary permit is denied, the governmental unit or department reviewing the application shall provide in writing to the applicant the reasons for denial, a notice for the right to appeal and the procedures for appeal.

c. An applicant denied a sanitary permit by a governmental unit may appeal the decision in accordance with ch. 68, Stats.

d. The appeal of the denial by the department for a sanitary permit shall be made in writing within 30 days from the date of the decision.

(e) A sanitary permit shall be issued by the appropriate governmental unit or the department in a format prescribed by the department.

Note: See appendix for further information relative to the permit format.

(4) TRANSFERS. A sanitary permit may be transferred from an owner to a subsequent owner, pursuant to s. 145.135 (1), Stats.

Note: Section 145.135 (1), Stats., reads in part: "A sanitary permit may be transferred from the holder to a subsequent owner of the land, except that the subsequent owner must obtain a new copy of the sanitary permit from the issuing agent."

(5) EXPIRATION. Pursuant to s. 145.135 (1), Stats., a sanitary permit shall expire 2 years from the date of issuance unless renewed in accordance with sub. (6).

(6) RENEWALS. (a) 1. The application for renewal of a sanitary permit shall be made in a format prescribed by the department.

Note: See appendix for further information relative to the application for renewal format.

2. The application for renewal of a sanitary permit shall be submitted to the department or the appropriate governmental unit in accordance with sub. (2) (b).

(b) The renewal of a sanitary permit shall be contingent upon the proposed POWTS or the proposed modification of an existing POWTS conforming with the rules of this chapter in effect at the time the sanitary permit is renewed.

(7) REVOCATION. (a) The department may revoke a sanitary permit issued under this section for any false statements or misrepresentation of facts on which the sanitary permit was issued.

(b) A governmental unit may revoke a sanitary permit that the governmental unit has issued under this section for any false statements or misrepresentation of facts on which the sanitary permit was issued.

(c) The revocation of a sanitary permit and the reasons for revocation shall be conveyed in writing to the individual to whom the sanitary permit was issued or transferred.

(d) If a sanitary permit is revoked, the installation or modification of a POWTS may not commence or continue until another sanitary permit is obtained.

(8) POSTING. When a sanitary permit is obtained under sub. (2), the sanitary permit shall:

(a) Be posted in such a location and manner on the proposed site where the POWTS is to be installed or modified so that the information on the permit is visible for inspection; and

(b) Remain posted until:

1. The POWTS installation or modification is completed; and
2. An opportunity for a final inspection occurs in accordance with s. Comm 83.26.

History: Cr. Register, April, 2000, No. 532, eff. 7-1-00; CR 02-129: am. (2) (c) 4., (3) (b) and (c) Register January 2004 No. 577, eff. 2-1-04.

**Comm 83.22 Plan review and approval. (1) SUBMISSION OF PLANS.** (a) Plans shall be submitted to the department, a designated agent or the governmental unit in accordance with this section for all of the following types of installations or modifications:

1. The installation or construction of a POWTS.
2. The replacement or addition of a POWTS treatment component.
3. The replacement or addition of a POWTS holding component.
4. The replacement or addition of a POWTS dispersal component.

(b) Plans for the types of POWTS delineated in Table 83.22-1 shall be submitted to the department for review.

(c) Plans for the types of POWTS delineated in Table 83.22-2 shall be submitted for review to the department or a designated agent.

Note: See s. Comm 83.23 for more information relative to designated agents.

(d) Plans for the types of POWTS delineated in Table 83.22-3 shall be submitted for review to the appropriate governmental unit where the POWTS is located or will be located.

**Table 83.22-1  
Plan Submissions to Department**

Type of Installation	
1.	POWTS owned by the state.
2.	Facilities owned by the state and served by POWTS.
3.	POWTS that will not completely utilize treatment and dispersal technologies or methods either approved under s. Comm 84.10 (2) or (3) or recognized under s. Comm 83.61.
4.	POWTS treating domestic wastewater combined with industrial wastes. <sup>a</sup>
5.	Experiments under s. Comm 83.27.

<sup>a</sup> See s. Comm 83.32 (3) (a).

**Table 83.22-2  
Plan Submissions to Department or Designated Agent**

Type of Installation	
1.	POWTS that will completely utilize treatment and dispersal technologies or methods either approved under s. Comm 84.10 (2) or (3) or recognized under s. Comm 83.61.
2.	POWTS that collect and hold all wastewater of the facilities served and utilize holding components either recognized under s. Comm 84.10 (2) or (3) or recognized under s. Comm 83.61.

Note: Pursuant to s. 145.19 (2), Stats., governmental units may require separate plan examination fees or include these fees in the cost of the sanitary permit.

**Table 83.22-3**  
**Plan Submissions to Governmental Unit**

Type of Installation	
1.	POWTS that will serve not more than two one- or 2-family dwellings and their accessory buildings utilizing technologies or methods either recognized under s. Comm 84.10 (2) or (3) or recognized under s. Comm 83.61, and using gravity distribution of the effluent to an in-ground distribution cell.

Note: Pursuant to s. 145.19 (2), Stats., governmental units may require separate plan examination fees or include these fees in the cost of the sanitary permit.

(2) PLANS AND SPECIFICATIONS. (a) 1. When plans are submitted to the department or designated agent for review, at least 3 sets of plans and one set of specifications shall be provided.

Note: Specifications for a project do not have to be a separate document but may be delineated on the plans.

2. Plans and specifications submitted for review shall be clear, legible and permanent copies.

3. Plans submitted for review shall include all of the following:

a. Details and configuration layouts depicting how the design is to be constructed and how the design is to accomplish the treatment in accordance with ss. Comm 83.43 and 83.44 and dispersal that is claimed or the holding of wastewater.

b. Specifications, including a description of the materials for the project and the installation or construction practices and methods to be employed.

c. A site plan with a bench mark either scaled or dimensioned, delineating all treatment and dispersal components and their relationship to any items listed in Table 83.43-1.

(b) 1. All plans submitted for review shall be accompanied by sufficient data and information to determine if the proposed POWTS or modification of an existing POWTS and their performance will conform with chs. Comm 82 to 84 including, but not limited to all of the following:

a. A plan review application form specified by the department.

Note: See appendix for an example of the plan review application form.

b. The minimum and maximum wastewater flow and load of the proposed project and the method or rationale for determining the flow and load.

c. Documentation to support treatment and dispersal claims.

d. A management plan for the proposed design reflecting conformance to subch. V.

e. A soil and site evaluation report in accordance with s. Comm 85.40 for those POWTS components that consist in part of in situ soil.

f. A description of a contingency plan in the event the proposed POWTS fails and cannot be repaired.

2. In addition to the information required under subd. 1., plans for one or more holding tanks serving a large commercial, industrial, recreational or residential development with an estimated daily wastewater flow of 3,000 gallons or more shall include information pursuant to s. NR 113.07 (1) (e).

Note: Section NR 113.07 (1) (e) reads as follows:

Large commercial, industrial, recreational or residential development holding tank systems that singly or when added together or increased by successive additions generate 3000 gallons of septage per day or greater shall contract with a wastewater treatment facility for treatment of the septage. The contract terms shall provide assurance that the septage from the system will continually be conveyed to, and accepted, at the wastewater treatment facility. If a service area designation exists, the wastewater treatment facility shall amend the service area to include the commercial, industrial, recreational or residential development. The department may not indicate sufficient disposal capacity to the department of commerce, until the service area adjustments have been completed and approved.

3. In addition to the information required under subd. 1., plans for a POWTS that is to serve a dwelling where the design of the POWTS is not based upon the number of bedrooms within the

dwelling shall be accompanied by information documenting that design condition on the deed for the property.

4. In addition to the information required under subd. 1., plans for an experimental POWTS shall be accompanied by information required under s. Comm 83.27 (3).

5. In addition to the information required under subd. 1., plans for a POWTS which is to serve more than one structure or building shall be accompanied by information that does all of the following:

a. Describes the legal entity, public or private, that has responsibility for the operation and maintenance of the POWTS.

b. Includes a copy of a recorded legal document that identifies all the parties that have ownership rights and are responsible for the operation and maintenance of the POWTS.

6. a. In addition to the information required under subd. 1., plans for a POWTS with a design wastewater flow exceeding 12,000 gallons per day shall not be approved until documentation has been submitted to the department indicating that the department of natural resources has concurred with the design of the POWTS.

Note: The Wisconsin department of natural resources requires that a Wisconsin Pollutant Discharge Elimination System (WPDES) permit must be obtained prior to the start of operation for a POWTS with a design flow exceeding 12,000 gallons per day pursuant to ch. 283, Stats.

b. Solely for the purpose of determining the applicability of subd. 6. a., the design wastewater flow of 12,000 gpd shall be deemed equivalent to 85 bedrooms for residential dwellings, including one- and 2-family dwellings, multi-family dwellings and mobile homes.

c. Solely for the purpose of determining the applicability of subd. 6. a., the design wastewater flow of 12,000 gpd for commercial facilities shall be calculated using the estimated wastewater flows specified in s. A-83.43 (6) of the appendix.

d. Solely for the purpose of determining the applicability of subd. 6. a., for residential dwellings combined with commercial facilities the design wastewater flow of 12,000 gpd shall be calculated by prorating the number of bedrooms on the basis of 85 bedrooms equaling 12,000 gpd for the residential dwellings and using the estimated flow under s. Comm 83.43 (3) (a) and s. A-83.43 (6) of the appendix to calculate the design flow for the commercial facilities.

e. For the purpose of determining the applicability of subd. 6. a., the design wastewater flow of 12,000 gpd shall include the design wastewater flow of all POWTS that are located on the same property or on properties under the same ownership and where the perimeter of a distribution cell of a POWTS dispersal component for one POWTS is less than 1,500 feet from the perimeter of a distribution cell of a POWTS dispersal component of any other POWTS under the same ownership.

f. For the purpose of determining the applicability of subd. 6. a., the combined design wastewater flow shall include that of any existing POWTS which falls within the parameters of subd. 6. e.

g. Under subd. 6. a., the same ownership is defined to be a person, group of persons or a corporation which owns a majority interest in the properties where majority ownership is based upon a majority of the issued voting stock, a majority of the members if no voting stock is issued, a majority of the board of the directors or comparable governing body or participation of each general partner in the profits of a partnership.

(c) Plans and specifications which are required to be submitted for review under sub. (1) shall be one of the following:

1. Signed and sealed in accordance with s. A-E 2.02 by an individual who is registered by the department of regulation and licensing as an architect, engineer, designer of plumbing systems or designer of private sewage systems.

2. Signed, including license number, and dated by an individual who is responsible for the installation of the POWTS and who

is licensed by the department as a master plumber or master plumber-restricted service.

(d) Plans submitted to the department for review shall be accompanied by a fee in accordance with ss. Comm 2.61 and 2.65.

**(3) PLAN REVIEW PROCESS.** (a) *Time limits.* The department shall review and make a determination on the submission of a plan within 15 business days after receiving all the required information and fees.

*Note:* See appendix for further information regarding the locations of the department's offices where plans may be submitted for review.

(b) *Conditional approval.* 1. If, upon review, the applicable reviewing agency determines that the plans conform to this chapter and chs. Comm 82 and 84, a conditional approval shall be granted in writing.

2. All conditions indicating nonconformance to this chapter and chs. Comm 82 and 84 shall be corrected before or during installation.

(c) *Denial of approval.* If, upon review, the applicable reviewing agency determines that the plans do not conform to this chapter or chs. Comm 82 and 84, the request for conditional approval shall be denied in writing.

**(4) REVISIONS.** (a) Except as provided in par. (e), a modification to the design of a POWTS for which a plan has been previously granted approval under sub. (3) (b) shall be submitted to the applicable reviewing agency for review in accordance with this section, if the proposed modification involves any one of the following:

1. The replacement or addition of a POWTS treatment component.
2. The replacement or addition of a POWTS holding component.
3. The replacement or addition of a POWTS dispersal component.
4. A change to one or more dispersal components involving any of the following:
  - a. Location outside suitable evaluated areas or proposed depths.
  - b. Size.
  - c. Type of pressure distribution dispersal component.

(b) The installer of a POWTS may not implement or undertake the proposed revisions under par. (a) until written approval is obtained from the applicable reviewing agency.

(c) Revisions to previously approved plans shall be reviewed in accordance with sub. (3).

(d) If revisions under par. (a) are submitted to and approved by the department, the owner of the site for the POWTS shall file the revisions with the county which issued the sanitary permit.

(e) A modification to the design of a POWTS for which a plan has been previously granted approval under sub. (3) (b) shall be submitted to the applicable agency responsible for issuing the sanitary permit, if the proposed modification involves a change to one or more dispersal components involving the orientation with respect to the slope of the landscape.

**(5) LIMITATION OF RESPONSIBILITY.** A conditional approval of a plan by the department may not be construed as an assumption by the department of any responsibility for the design of the POWTS or any component of the system. The department does not hold itself liable for any defects in construction, or for any damages that may result from a specific installation.

**(6) REVOCATION OF APPROVAL.** (a) The department may revoke any plan approval issued under this section for any false statements or misrepresentation of facts on which the approval was based.

(b) The designated agent or governmental unit may revoke any plan approval issued by the designated agent or governmental

units for any false statements or misrepresentation of facts on which the approval was based.

(c) The revocation of a plan approval and the reasons for revocation shall be conveyed in writing to the submitter of the plans as noted on the application.

(d) If a plan approval is revoked, the installation or alteration of a POWTS may not continue until another plan approval is obtained.

**(7) EVIDENCE OF APPROVAL.** (a) When plans are required to be approved by the department or designated agent under sub. (1), the plumber responsible for the installation of a POWTS or the modification of an existing POWTS shall keep at the construction site at least one set of plans bearing evidence of approval by the department or designated agent and at least one copy of specifications.

(b) The plans and specifications shall be maintained at the construction site until the POWTS installation or modification is completed and an opportunity for a final inspection occurs in accordance with s. Comm 83.26.

(c) The plans and specifications shall be made available to the department or the governmental unit upon request.

*History:* Cr. Register, April, 2000, No. 532, eff. 7-1-00; CR 02-129: am. (2) (b) 6, a. and e. and (4) (a) (intro.), r. (4) (a) 4. c., renum. and am. (4) (a) 4. d. to be (4) (a) 4. c., cr. (4) (e) Register January 2004 No. 577, eff. 2-1-04.

**Comm 83.23 Review agent status.** (1) Upon request from a governmental unit, the department may delegate to the governmental unit the responsibility to review plans for one or more of the types of POWTS delineated in Table 83.22-2 which are to be or are located within the jurisdiction of that governmental unit.

(2) A request by a governmental unit to review plans for the types of POWTS delineated in Table 83.22-2 shall be made in writing. The request shall include all of the following:

- (a) The types of POWTS for which delegation is desired.
- (b) Information delineating how the plans are to be processed and reviewed.
- (c) Information on how plan review decisions are to be recorded and maintained.

(3) The delegation of plan review by the department shall be contingent upon a governmental unit's request demonstrating sufficient capabilities to complete the reviews, including all of the following:

- (a) The utilization of one or more individuals who are certified by the department as a POWTS inspector to perform the plan review.
- (b) The utilization of one or more individuals, who are certified soil testers, to provide assistance in the plan review process.

*Note:* The requirements of this subsection do not require the utilization of 2 individuals to perform plan review. A single individual who holds a certification as a certified POWTS inspector and as a certified soil tester may fulfill the requirements under pars. (a) and (b).

(4) (a) The department shall provide the governmental unit with a written decision of delegation or denial of delegation relative to a request under this section concerning plan review.

(b) The delegation for plan review shall be contingent upon the governmental unit acknowledging that the submission and review of plans under s. Comm 83.22 (1) may, at the discretion of the submitter, be made to the department or the designated agent.

(5) The department shall include as part of governmental unit audits conducted under s. 145.20 (3) (b), Stats., an evaluation of the plan review functions which are delegated to a governmental unit under this section.

(6) A governmental unit that wishes to discontinue the delegated plan review function under this section shall notify the department in writing at least 30 days prior to the discontinuance.



(7) The recognition as a review agent may be revoked by the department in accordance with s. 145.20 (3) (a) 2., Stats.

History: Cr. Register, April, 2000, No. 532, eff. 7-1-00; CR 02-129: am. (3) (a) and (b) Register January 2004 No. 577, eff. 2-1-04.

**Comm 83.24 Petitions for variance. (1)** The department shall consider and may grant a variance to a provision of this chapter in accordance with ch. Comm 3.

Note: The petition for variance process is to allow the owner of a proposed or existing POWTS to ask the department's recognition of an alternative method or means for complying with the intent of a specific rule.

(2) (a) Pursuant to s. 145.24, Stats., the department may not approve a petition for variance for an existing POWTS which is determined to be a failing private onsite wastewater treatment system.

(b) For the purposes of this subsection, the department shall consider a petition for variance if the existing POWTS is not considered a failing private onsite wastewater treatment system.

History: Cr. Register, April, 2000, No. 532, eff. 7-1-00.

**Comm 83.25 Governmental programs. (1) DELEGATION OF RESPONSIBILITIES.** (a) Pursuant to s. 145.20 (1) (am), Stats., the delegation by a governmental unit of the administration and enforcement of this chapter to a town sanitary district or public inland lake protection and rehabilitation district shall be by ordinance.

(b) A copy of an ordinance delegating administration and enforcement of this chapter to a town sanitary district or public inland lake protection and rehabilitation district shall be forwarded to the department at least 30 days prior to the effective date of the ordinance.

(2) **ISSUANCE OF BUILDING PERMITS.** (a) *General.* Pursuant to s. 145.195, Stats., the issuance of building permits by a municipality for unsewered properties shall be in accordance with this subsection.

Note: See appendix for a reprint of s. 145.195, Stats.

(b) *New construction.* A municipality may not issue a building permit to commence construction or installation of a structure that necessitates the use of a POWTS to serve the structure, unless:

1. The owner of the property possesses a sanitary permit for the installation of a POWTS in accordance with s. Comm 83.21; or

Note: Section Comm 83.21 outlines the procedures for the issuance of sanitary permits. Sections 145.135 and 145.19, Stats., mandate that no private sewage system may be installed unless the owner of the property holds a valid sanitary permit.

2. A POWTS of adequate capability and capacity to accommodate the wastewater flow and contaminant load already exists to serve the structure.

Note: See ss. Comm 83.02 and 83.03 concerning the application of current code requirements to existing POWTS.

(c) *Construction affecting wastewater flow or contaminant load.* 1. A municipality may not issue a building permit to commence construction of any addition or alteration to an existing structure when the proposed construction will modify the design wastewater flow or contaminant load, or both, to an existing POWTS, unless the owner of the property:

a. Possesses a sanitary permit to either modify the existing POWTS or construct a POWTS to accommodate the modification in wastewater flow or contaminant load, or both; or

b. Provides documentation to verify that the existing POWTS is sufficient to accommodate the modification in wastewater flow or contaminant load, or both.

2. For the purpose of this paragraph, a modification in wastewater flow or contaminant load shall be considered to occur:

a. For commercial facilities, public buildings, and places of employment, when there is a proposed change in occupancy of the structure; or the proposed modification affects either the type or number of plumbing appliances, fixtures or devices discharging to the system; and

b. For dwellings, when there is an increase or decrease in the number of bedrooms.

(d) *Documentation of existing capabilities.* Documentation to verify whether an existing POWTS can accommodate a modification in wastewater flow or contaminant load, or both, shall include at least one of the following:

1. A copy of the plan for the existing POWTS that delineates minimum and maximum performance capabilities and which has been previously approved by the department or the governmental unit.

2. Information on the performance capabilities for the existing POWTS that has been recognized through a product approval under ch. Comm 84.

3. A written investigative report prepared by an architect, engineer, designer of plumbing systems, designer of private sewage systems, master plumber, master plumber-restricted service or certified POWTS inspector analyzing the proposed modification and the performance capabilities of the existing POWTS.

(e) *Setbacks.* 1. A municipality may not issue a building permit for construction of any structure or addition to a structure on a site where there exists a POWTS, unless the proposed construction conforms to the applicable setback limitations under s. Comm 83.43 (8) (i).

2. The applicant for a building permit shall provide documentation to the municipality issuing the building permit showing the location and setback distances for the proposed construction relative to all of the following:

a. Existing POWTS treatment components.

b. Existing POWTS holding components.

c. Existing POWTS dispersal components.

Note: A municipality which issues building permits may delegate to the governmental unit responsible for issuing sanitary permits the determination of whether the proposed construction will affect or interfere with an existing POWTS relating to capability or location of the existing POWTS.

Note: See appendix for further information regarding setbacks.

History: Cr. Register, April, 2000, No. 532, eff. 7-1-00; correction in (2) (a) made under s. 13.93 (2m) (b) 7., Stats; CR 02-129: am. (2) (a) Register January 2004 No. 577, eff. 2-1-04.

**Comm 83.26 Inspections and testing. (1)** (a) Pursuant to s. 145.02 (3) (c), Stats., the department or governmental unit may inspect the construction, installation, operation or maintenance of a POWTS to ascertain whether the POWTS conforms to plans approved by the department or governmental unit, the conditions of approval and this chapter.

(b) The department may issue an order directing an immediate cessation of the installation of a POWTS or the modification to an existing POWTS for failure to comply with a corrective order.

(c) Pursuant to ss. 145.02 (3) (f) and 145.20 (1) (a) and (2) (f), Stats., an individual authorized by the department or a governmental unit to administer and enforce this chapter may issue orders to abate human health hazards relating to this chapter.

Note: Section Comm 5.66 delineates qualifications and responsibilities for POWTS inspectors.

(d) Pursuant to s. 145.20 (2) (e) and (g), Stats., nothing in this chapter shall limit a governmental unit's authority and power to inspect or require an evaluation of a POWTS, including an existing POWTS at times or for activities not covered under this subsection.

(2) (a) When a sanitary permit is required under s. Comm 83.21 (1), no part of a POWTS component may be covered nor any POWTS component put into service until the governmental unit or the department has had an opportunity to inspect the system in accordance with this subsection.

Note: Pursuant to s. 145.20 (2), Stats., an individual authorized by a governmental unit to administer and enforce the provisions of chs. Comm 82 to 87 relative to POWTS is required to be a certified POWTS inspector under s. Comm 5.66.

(b) The master plumber or the master plumber-restricted service responsible for the installation of a POWTS or the modification to an existing POWTS shall notify the governmental unit when the work will be or is ready for inspection. The notification

shall be in person, in writing or by telephone or other electronic communication in a format acceptable to the governmental unit performing the inspection.

(c) The master plumber or the master plumber-restricted service responsible for the installation of a POWTS or the modification shall maintain records of the inspection notifications. The records shall include the date and time of notification and the name of the person contacted.

(d) The master plumber or master plumber-restricted service responsible for the POWTS installation or modification shall provide the necessary equipment and properly licensed personnel required for the inspection as requested by the governmental unit or department.

(e) If an inspection is not made by the end of the next workday, excluding Saturdays, Sundays and holidays, after the requested inspection day, the master plumber or the master plumber-restricted service may proceed with the installation of the POWTS, including backfilling and covering.

(3) Pursuant to s. 145.20 (2) (g), Stats., a governmental unit by ordinance may require other inspections in addition to that specified under this section.

(4) A governmental unit shall maintain a written record of each inspection conducted for a POWTS. The record shall include information relative to all of the following:

- (a) The location of the POWTS.
- (b) The date of the inspection.
- (c) The nature and findings of the inspection.

(5) Before being put into service, components of a POWTS shall be tested in accordance with the manufacturer's specifications or as specified as a condition of approval under ss. Comm 83.22 and 84.10.

History: Cr. Register, April, 2000, No. 532, eff. 7-1-00.

**Comm 83.27 Experiments.** (1) The provisions of this chapter or ch. Comm 84 are not intended to prevent the design and use of an innovative method or concept for the treatment or dispersal of domestic wastewater which is not specifically addressed by this chapter, provided the experiment has been first approved by the department in accordance with s. Comm 84.50 (3).

(2) The department shall review a submittal of an experiment under this section with input from the technical advisory committee assembled under s. Comm 84.10 (3) (d).

(3) The protocol for a proposed experiment submitted to the department for consideration shall include all of the following:

- (a) The experiment shall be supervised by a professional who has experience in small-scale wastewater treatment.
- (b) The professional shall submit a vita of training and experience relative to small-scale wastewater treatment along with the application for the experiment.
- (c) A proposal shall be submitted for the experiment that includes at least all of the following:
  1. The purpose of the experiment.
  2. The theory and science behind the proposed experiment including a description of the systems or processes to be used as part of the experiment.
  3. The number of systems or components to be installed or modified as part of the experiment.
  4. The identification of the initial sites, if known, that will take part in the experiment.
  5. A letter of comment from the governmental unit or units where the experiment is to be conducted.
  6. The data to be collected and the method to be employed to collect the data.
  7. The duration of the proposed experiment.

(d) The experiment may not involve less than 5, and not more than 50 individual installations.

(e) An experiment shall be designed to provide definitive results within 5 years from the start of the experiment.

(f) An experiment on a site not previously developed shall include a contingency plan that provides for a code complying replacement POWTS, if the experiment fails to meet the required performance standards of this chapter.

(g) If the experiment is approved, the experimenter shall execute a signed agreement with the department setting forth the obligations of the parties.

(h) Within 6 months of the completion of the experiment, the results or conclusions shall be forwarded to the department.

History: Cr. Register, April, 2000, No. 532, eff. 7-1-00.

**Comm 83.28 Penalties.** Penalties for violations of this chapter shall be assessed in accordance with s. 145.12, Stats.

Note: Section 145.12 (4), Stats., indicates that any person who violates any order under s. 145.02 (3) (f) or 145.20 (2) (f) or any rule or standard adopted under s. 145.13 shall forfeit not less than \$10 nor more than \$1,000 for each violation. Each violation of an order under s. 145.02 (3) (f) or 145.20 (2) (f) or any rule or standard adopted under s. 145.13 constitutes a separate offense and each day of continued violation is a separate offense.

History: Cr. Register, April, 2000, No. 532, eff. 7-1-00.

**Comm 83.29 Range of responses.** (1) (a) Pursuant to s. 160.21, Stats., the department shall respond with any one or more of the actions delineated under Table 83.29 if the preventive action limits or enforcement standards enumerated in ch. NR 140 Tables 1 and 2 are exceeded at a point of standards application as a result of the performance of a POWTS, including a POWTS existing prior to July 1, 2000, except as provided in par. (b).

(b) Pursuant to s. 160.255, Stats., the design, installation, use or maintenance of a POWTS is not required to comply with the nitrate standard specified in ch. NR 140 Table 1, except as provided under s. Comm 83.03 (5).

Table 83.29

Department Range of Responses

- Gather more data relative to the cause and significance of the exceedance.
- Determine whether the situation is a human health hazard.
- Issue orders to change or comply with the management or maintenance plan of a specific POWTS or type of onsite wastewater system.
- Issue orders to conform with this chapter, including the prohibition of an activity or practice.
- Determine whether the exceedance is an isolated problem, or is likely to recur.
- Revise or revoke a product approval issued under ch. Comm 84 for a treatment or dispersal component.
- Revise the rules of this chapter or ch. Comm 81, 82, 84 or 85.

(2) Pursuant to s. 160.21 (2), Stats., the point of standards application relative to the performance of POWTS shall be:

(a) Any point of present groundwater use for potable water supply; and

(b) Any point beyond the boundary of the property on which the facility, practice or activity is located.

History: Cr. Register, April, 2000, No. 532, eff. 7-1-00; CR 02-129: am. (1) (a) Register January 2004 No. 577, eff. 2-1-04.

Subchapter III — General Requirements

**Comm 83.30 Purpose.** This subchapter establishes parameters for the types of POWTS that may be used and how a POWTS may be used.

History: Cr. Register, April, 2000, No. 532, eff. 7-1-00.

**Comm 83.31 Principles.** A POWTS shall be operated and used in such a manner so as not to render the POWTS inopera

tive or beyond its capabilities, and thereby, create a human health hazard.

**History:** Cr. Register, April, 2000, No. 532, eff. 7-1-00.

**Comm 83.32 Prohibitions and limitations. (1) PROHIBITIONS.** (a) Except as provided in s. Comm 83.03 (4), the introduction of wastewater or substances in such quantities or concentrations to a POWTS, including a POWTS existing prior to July 1, 2000, that results in exceeding the enforcement standards and preventive action limits specified in ch. NR 140 Tables 1 and 2 at a point of standards application shall be prohibited.

**Note:** Section Comm 83.03 (4) reads:

(4) **GROUNDWATER STANDARDS.** (a) Pursuant to s. 160.255, Stats., the design, installation, use or maintenance of a POWTS is not required to comply with the nitrate standard specified in ch. NR 140 Table 1, except as provided under sub. (5).

(b) Pursuant to s. 160.19 (2) (a), Stats., the department has determined that it is not technically or economically feasible to require that a POWTS treat wastewater to comply with the preventive action limit for chloride specified in ch. NR 140, Table 2, as existed on June 1, 1998.

(c) Substances deleterious to a POWTS shall be intercepted, diluted or treated in accordance with s. Comm 82.34 prior to the substance discharging into a POWTS.

(d) The use of a cesspool as a POWTS is prohibited, including any cesspool existing prior to July 1, 2000.

(e) The final discharge of domestic wastewater or POWTS effluent to open bodies of water is prohibited, including by means of plumbing outfall pipes existing prior to July 1, 2000.

(f) The final discharge of domestic wastewater or POWTS effluent to the ground surface is prohibited, including by means of plumbing outfall pipes existing prior to July 1, 2000.

(g) The infiltrative surface of a treatment or dispersal component of a POWTS existing prior to December 1, 1969, which consists in part of soil may not be located in bedrock or groundwater.

(h) The use of camping unit transfer containers as a POWTS holding component shall be restricted to campgrounds permitted by the department of health and family services under ch. HFS 178.

**(2) LOCAL PROHIBITIONS.** (a) A municipality may by ordinance prohibit or limit the installation and use of the following technologies, designs or methods as POWTS components:

1. A holding tank.
2. A constructed wetland as a POWTS treatment component.
3. An evapotranspiration bed as a POWTS treatment component.

(b) A municipality may enact ordinances that are more restrictive than the applicable state minimum standards for those POWTS existing prior to December 1, 1972, except as provided in s. Comm 83.03 (2) (b) 2.

**Note:** The date, December 1, 1972, reflects the point in time at which the state plumbing code became a state-wide uniformly applied code rather than just a minimum standard. Since December 1, 1969 to July 1, 2000, the state plumbing code required 36 inches of soil between the infiltrative surface of a POWTS and high groundwater or bedrock.

(c) A municipality may by ordinance restrict the ownership of a POWTS to a governmental entity or agency when the POWTS is to serve 2 or more structures or buildings that are located on more than one property.

**(3) LIMITATIONS.** (a) Industrial wastes and wastewater may not, unless approved by the department of natural resources, be introduced into a POWTS.

**Note:** The department of natural resources regulates the discharge of industrial wastes to land treatment systems under ch. NR 214. Section NR 214.02 reads in part:

"This chapter applies to those discharges of industrial wastes to land treatment systems not regulated under ch. NR 518. This includes but is not limited to liquid wastes, by-product solids and sludges generated by: fruit and vegetable processing, dairy products processing, meat, fish and poultry products processing, mink raising operations, aquaculture, commercial laundromat and motor vehicle cleaning operations and any other industrial, commercial or agricultural operation which results in a point

source discharge that has no detrimental effects on the soils, vegetation or groundwater of a land treatment system."

(b) Storm and clear water may be introduced into a POWTS, if the POWTS is designed to accept that wastewater. A POWTS may accept wastewater permitted under s. Comm 82.36 (3).

**Note:** Section Comm 82.36 (3) (a) permits the discharge of a maximum of 50 gallons per day of clear water wastes to a sanitary drain system connected to a publicly owned treatment works.

(c) Except as provided in ch. NR 116, no part of a POWTS may be installed in a floodway.

**Note:** See s. Comm 83.45 (6) for installations in a floodfringe.

**History:** Cr. Register, April, 2000, No. 532, eff. 7-1-00; **CR 02-129; am. (1) (e) and (f), (3) (a) and (b) Register January 2004 No. 577, eff. 2-1-04.**

**Comm 83.33 Abandonment.** A subsurface tank or pit that is no longer used as a POWTS component shall be abandoned by complying with all of the following:

(1) Disconnecting all piping to the tanks and pits.

(2) Sealing all disconnected piping to the tanks and pits in accordance with s. Comm 82.21 (2) (h).

(3) Pumping and disposing of the contents from all tanks and pits.

**Note:** The disposal of the contents from treatment tanks, distribution tanks, seepage pits and holding components is addressed in ch. NR 113 which is administered by the department of natural resources.

(4) Removing all tanks or removing the covers of the tanks or pits and filling the tanks and pits with soil, gravel or an inert solid material.

**Note:** Pursuant to s. 281.45, Stats., municipalities and sanitary districts may determine the availability of, and require connection to, public sewers. Section 281.45, Stats., reads in part:

"HOUSE CONNECTIONS. To assure preservation of public health, comfort and safety, any city, village or town or town sanitary district having a system of water works or sewerage, or both, may by ordinance require buildings used for human habitation and located adjacent to a sewer or water main, or in a block through which one or both of these systems extend, to be connected with either or both in the manner prescribed. If any person fails to comply for more than 10 days after notice in writing the municipality may impose a penalty or may cause connection to be made, and the expense thereof shall be assessed as a special tax against the property."

**History:** Cr. Register, April, 2000, No. 532, eff. 7-1-00.

## Subchapter IV — Design and Installation

**Comm 83.40 Purpose.** This subchapter establishes minimum parameters for the design and installation of a POWTS for the purpose of:

(1) Safeguarding public health;

(2) Minimizing the level of substances which have a reasonable probability of entering waters of the state; and

(3) Delineating measures, conditions and performance standards by which to evaluate designs.

**History:** Cr. Register, April, 2000, No. 532, eff. 7-1-00.

**Comm 83.41 Principles. (1)** A POWTS shall be designed to hold wastewater or reduce the contaminant load and disperse the flow of wastewater as specified in this subchapter.

(2) A POWTS shall be designed to have sufficient capacity to accommodate the anticipated quantities of wastewater that will be discharged into the system.

(3) A POWTS intended to treat and disperse wastewater shall be designed to have sufficient ability to treat or separate out the anticipated types, quantities and concentrations of wastewater contaminants to be discharged into the system so that the dispersed wastewater will not create a human health hazard.

(4) A POWTS shall be designed to disperse wastewater below the surface of the ground at a rate that promotes long term assimilation into the soil and limits the possibility of surfacing.

**History:** Cr. Register, April, 2000, No. 532, eff. 7-1-00.

**Comm 83.42 Application. (1) DESIGN BASIS.** The design of a POWTS shall be based on the methods and limitations outlined in this subchapter or on other documented data acceptable to the department.

(2) **DESIGN RELATION TO ACTUAL FLOWS AND CONTAMINANT LOADS.** For any situation where it is known that the wastewater flow or contaminant load exceeds the parameters of this sub chapter, the POWTS shall be designed in relation to the known flow or load.

(3) **DESIGN CONSIDERATIONS.** The evidence to support assertions relative to contaminant reduction and hydraulic dispersal shall include at least all of the following:

- (a) The flow and contaminant load of the influent wastewater.
- (b) The ability of all treatment and dispersal components to reduce contaminant load and disperse hydraulic flow into the environment.
- (c) The flow velocities and friction losses throughout the system based upon accepted engineering practice.

History: Cr. Register, April, 2000, No. 532, eff. 7-1-00.

**Comm 83.43 General requirements. (1) MATERIALS.** The components of a POWTS shall be constructed of materials and products that are of a type recognized under this chapter or ch. Comm 84.

(2) **DESIGN FLOW.** In order to accommodate peak wastewater flow, the design wastewater flow of a POWTS shall equal at least 150% of the estimated daily flow generated from the source or sources, unless otherwise approved by the department.

(3) **ESTIMATED DAILY COMBINED FLOW FOR A POWTS SERVING A DWELLING.** The estimated daily wastewater flow of combined graywater, clear water and blackwater from a dwelling shall be based on one or more of the following:

- (a) The following equation:

$$100 \text{ gallons} \times B = F$$

Where: B = number of bedrooms, based on 2 persons per bedroom, unless otherwise approved by the department.

F = Estimated daily wastewater flow per dwelling per day (in gallons), excluding storm water discharges.

(b) A detailed estimate of wastewater flow based upon per capita occupancy or usage of the dwelling or per function occurrence within the dwelling.

(4) **ESTIMATED DAILY SEGREGATED GRAYWATER FLOW FOR A POWTS SERVING A DWELLING.** The estimated daily wastewater flow of graywater and clear water from a dwelling shall be based on one or more of the following:

- (a) The following equation:

$$60 \text{ gallons} \times B = F$$

Where: B = number of bedrooms, based on 2 persons per bedroom, unless otherwise approved by the department.

F = Estimated daily graywater flow per dwelling per day (in gallons), excluding storm water discharges.

(b) A detailed estimate of graywater flow based upon per capita occupancy or usage of the dwelling or per function occurrence within the dwelling.

(5) **ESTIMATING SEGREGATED BLACKWATER FLOW FOR A POWTS SERVING A DWELLING.** The estimated daily wastewater flow of blackwater from a dwelling shall be based on one or more of the following:

- (a) The following equation:

$$40 \text{ gallons} \times B = F$$

Where: B = number of bedrooms, based on 2 persons per bedroom, unless otherwise approved by the department.

F = Estimated daily blackwater flow per dwelling per day (in gallons).

(b) A detailed estimate of blackwater flow based upon per capita occupancy or usage of the dwelling or per function occurrence within the dwelling.

(6) **ESTIMATING WASTEWATER FLOW FOR COMMERCIAL FACILITIES.** The estimated daily wastewater flow of clear water, graywater, blackwater, or combined graywater-blackwater flow from public buildings and places of employment shall be based on one or more of the following:

(a) Measured daily wastewater flow over a period of time representative of the facility's use or occupancy.

(b) A detailed estimate of wastewater flow based upon per capita occupancy or usage of the facility or per function occurrence within the facility.

Note: See appendix for further information.

(7) **ESTIMATING CONTAMINANT LOADS.** Estimates of contaminant loads from dwellings and public facilities shall be based on a detailed analysis including all contaminants listed in s. Comm 83.44 (2) (a).

Note: See appendix for further information.

Note: See Note under s. Comm 83.32 (3) for information relative to industrial wastes.

(8) **GENERAL DESIGN REQUIREMENTS. (a) Flow velocity.** 1. Piping within a POWTS shall be designed and installed to supply wastewater to POWTS treatment and dispersal components while maintaining the velocity required to ensure operation of the POWTS.

2. Gravity flow piping between POWTS components shall be installed at a pitch that produces a computed flow velocity of at least one foot per second when flowing half full.

3. Pressurization equipment or devices and piping to be utilized upstream of a POWTS treatment or dispersal component consisting in part of in situ soil shall be designed and installed to produce a computed velocity of at least 2 feet per second.

4. Gravity piping within a POWTS treatment or dispersal component consisting in part of in situ soil shall be installed level or pitched downstream a maximum 4 inches per 100 feet.

(b) *Distribution and drain pipe sizing.* The piping within a POWTS shall be of a diameter to permit the operation of the POWTS.

(c) *Frost protection.* All POWTS components shall be protected from freezing temperatures that could detrimentally affect component operation to provide wastewater conveyance, treatment or dispersal.

(d) *Component placement.* The orientation of a POWTS treatment or dispersal component consisting in part of in situ soil shall take into account landscape variations in elevation, slope orientation, and other conditions that could affect component performance relative to dispersal or aeration.

(e) *Alarms or warning systems.* 1. a. A POWTS component utilizing a mechanical device to treat wastewater or to distribute effluent shall be provided with an automatic visual or audible means of notifying the user of the POWTS of the failure of the mechanical device.

Note: In accordance with s. Comm 16.28, an alarm that is electrically powered is to be on a separate circuit from the circuit supplying power to the mechanical device.

b. An alarm indicating the failure of a pump shall remain audible or visible until manually turned off.

c. Where duplex pumping equipment is employed to provide continuous component operation in the event that one pump fails, the pumps shall be installed in such a manner so as to provide the continuous operation automatically.

2. A POWTS holding tank shall be provided with an automatic visual or audible means of notifying the user of the POWTS of the necessity for servicing.

(f) *Accessibility.* The design of a POWTS shall include provisions to provide access to all components that require maintenance or observation.

(g) *Anchoring system components.* An exterior subsurface POWTS treatment tank or POWTS holding component to be installed in an area subject to saturated conditions shall be installed so as to prevent flotation of the tank or component.

**Note:** See appendix for further information.

(h) *Treatment byproducts.* 1. All treatment byproducts discharged from or as a result of operating a POWTS shall be disposed of so as not to create a human health hazard.

**Note:** The disposal of the contents of holding tanks and the sludge, scum, and contaminated liquids from treatment tanks and components is regulated by the department

of natural resources under chs. NR 113 and NR 204.

2. Deleterious or hazardous materials segregated out from effluent flows shall be disposed of in a manner conforming with the rules of the state agency having jurisdiction.

3. Effluent from a POWTS shall be dispersed so as not to create a human health hazard.

4. All POWTS components within a building or structure shall be gas tight unless provisions are made assuring the safety of individuals entering the building or structure.

(i) *Site parameters and limitations.* POWTS treatment, holding and dispersal components shall be located so as to provide the minimum horizontal setback distances as outlined in Table 83.43-1 as safety factors for public health, waters of the state and structures in the event of component failure.

**Note:** Chapter NR 812 establishes upslope location criteria for wells relative to contamination sources.

**Table 83.43-1**

**Horizontal Setback Parameters**

Physical Feature	POWTS Treatment Component Consisting in Part of In Situ Soil or Dispersal Component	Exterior Subsurface Treatment Tank or Holding Tank Component	Servicing, Suction Lines and Pump Discharge Lines
Building	10 feet	5 feet <sup>a</sup>	none <sup>b</sup>
Property Line	5 feet	2 feet	2 feet
Swimming Pool	15 feet	none <sup>b</sup>	none <sup>b</sup>
OHWL of Navigable Waters	50 feet	10 feet	10 feet
Water Service and Private Water Main	10 feet	10 feet	10 feet
Public Water Main	ch. NR 811	ch. NR 811	ch. NR 811
Well	chs. NR 811 & 812	chs. NR 811 & 812	chs. NR 811 & 812

OHWL = Ordinary High-Water Mark

<sup>a</sup> Except camping unit transfer containers.

<sup>b</sup> See s. Comm 83.43 (8) (f) relative to accessibility.

**Note:** The department of transportation under s. Trans 233.08 establishes setback limits from the centerline of state trunk highways or connecting highways to structures and improvements which include septic systems.

(j) *Service suction and discharge lines.* 1. A suction line or discharge line serving a holding tank for servicing purposes shall comply with all of the following:

a. A pipe serving as the suction or discharge line shall be of an acceptable type in accordance with ch. Comm 84.

b. A suction or discharge line shall terminate with a service port consisting of a quick disconnect fitting with a removable plug.

c. The service port of a suction or discharge line shall terminate at least 2 feet above final grade.

d. The service port of a suction or discharge line shall be identified as such with a permanent sign with lettering at least 1/2 inch in height.

e. The service port of a suction or discharge line shall be secured to a permanent support that is capable of withstanding the loads and forces placed on the port.

f. A suction or discharge line shall be at least 3 inches in diameter.

2. A suction line serving a holding tank may not be installed in such a manner or arrangement that the tank can be drained by gravity or siphonic action.

3. Where a lift station is employed for servicing a holding tank, the pump discharge line shall conform with subd. 1., except as provided in subd. 3. a. and b.

a. A discharge line from the lift station shall be at least 2 inches in diameter.

b. The lift station pump shall be activated by means of a keyed-switch at the service port.

**History:** Cr. Register, April, 2000, No. 532, eff. 7-1-00; CR 02-129: am. (2), (6) (intro.), and Table 83.43-1 Register January 2004 No. 577, eff. 2-1-04.

**Comm 83.44 Parameters for POWTS components consisting of in situ soil.** (1) **EVALUATION.** POWTS treatment and dispersal components consisting in part of in situ soil shall be evaluated in accordance with ch. Comm 85.

(2) **INFLUENT QUALITY.** (a) The quality of influent discharged into a POWTS treatment or dispersal component consisting in part of in situ soil shall be equal to or less than all of the following:

1. A monthly average of 30 mg/L fats, oil and grease.

2. A monthly average of 220 mg/L BOD<sub>5</sub>.

3. A monthly average of 150 mg/L TSS.

(b) The monthly average under par. (a) shall be calculated as the sum of all measurements taken over 30 consecutive days, with at least 6 measurements occurring on 6 separate days, and divided by the number of measurements taken during that period.

(c) Influent discharged to a POWTS treatment or dispersal component that consists in part of unsaturated soil may not contain any solid or suspended solid exceeding 1/8 inch in diameter.

**Note:** Under s. Comm 83.03 (1) (b), the replacement of a POWTS anaerobic treatment tank (septic tank) in conjunction with this rule would limit any solids within the effluent leaving the tank to a maximum of 1/8-inch diameter.

(3) **INFILTRATIVE SURFACE.** (a) The infiltrative surface of unsaturated soil to which influent is discharged shall be located at least 24 inches above the estimated highest groundwater elevation and bedrock.

(b) 1. At least 6 inches of the soil separation required under par. (a) shall be an in situ soil type for which soil treatment capability has been credited under Table 83.44-3.

2. The purpose of the 6 inches of in situ soil under subd. 1. shall be to assure that the influent will be assimilated into the original subsurface soils without ponding on the ground surface.

(c) The infiltrative surface of unsaturated soil to which influent is discharged shall be located at least one inch below the finished grade.

(4) CAPABILITIES. (a) 1. a. Except as provided under subd. 2., the dispersal capability of a POWTS treatment or dispersal component consisting in part of unsaturated soil shall be limited to that specified in Table 83.44-1 or Table 83.44-2 based upon the influent quality concentrations being applied.

b. Under subd. 1. a., the influent quality parameter with the highest concentration shall determine the maximum application rate.

c. Except as provided in par. (c), the soil conditions at the infiltrative surface of unsaturated soil to which influent is to be discharged shall be used to establish the maximum application rate for a POWTS dispersal design.

d. The moist soil consistence of the soil horizon in which the infiltrative surface of a POWTS treatment or dispersal component will be located may not be stronger than firm or any cemented classification.

e. The maximum soil application for soil with moderate to strong platy structure shall not exceed 0.2 gals./sq. ft./day for effluent concentrations of  $\leq 30$  mg/L BOD<sub>5</sub> and TSS and shall be 0.0 gals./sq. ft./day for effluent concentrations of  $> 30$  mg/L BOD<sub>5</sub> and TSS.

f. The application rates specified under Table 83.44-1 shall only be recognized where the percolation results have been filed with the governmental unit before July 2, 1994.

2. Maximum soil application rates other than those specified in Tables 83.44-1 or 83.44-2 may be employed for the design of a POWTS treatment or dispersal component consisting in part of in situ soil if documentation is submitted and approved under s. Comm 83.22 and is based on soil permeability and evapotranspiration estimates correlated to specific soil characteristics described in a detailed morphological soil evaluation.

(b) The treatment capability of a POWTS treatment component consisting of unsaturated soil shall be limited to that specified in Table 83.44-3, unless otherwise approved by the department.

(c) The design of a treatment or dispersal component consisting in part of in situ soil shall reflect restrictive soil horizons that affect treatment or dispersal.

(5) EFFLUENT DISTRIBUTION. (a) 1. Except as provided in subd. 2., the distribution of effluent to a treatment or dispersal

component shall be by means of pressure distribution as specified in Tables 83.44-2 and 83.44-3.

2. Pressure distribution is not required when rehabilitating an existing non-pressurized in situ soil treatment or dispersal component that is persistently ponded and that has at least 24 inches of unsaturated soil beneath the infiltrative surface of the component.

(b) 1. The distribution of effluent to in situ soil shall be accomplished by means of pressurized distribution, if the value for BOD<sub>5</sub>, TSS and fecal coliform of the effluent is equal to or less than all of the following:

- a. A monthly average of 30mg/L BOD<sub>5</sub>.
- b. A monthly average of 30mg/L TSS.
- c. A monthly geometric mean of 10<sup>4</sup> fecal coliform cfu per 100 ml.

Note: "CFU" means colony forming units.

2. The geometric mean under subd. 1. c. shall be determined on the basis of measurements taken over 30 consecutive days, with at least 6 measurements occurring on 6 separate days.

(c) Each dose of effluent by means of pressurized distribution into a treatment or dispersal component consisting in part of in situ soil may not be less than 5 times the void volume of the POWTS distribution laterals.

**Table 83.44-1  
Maximum Soil Application Rates  
Based Upon Percolation Rates**

Percolation Rate (minutes per inch)	Maximum Monthly Average	
	BOD <sub>5</sub> > 30mg/L ≤ 220 mg/L TSS > 30 mg/L ≤ 150 mg/L (gals/ sq ft/day)	BOD <sub>5</sub> ≤ 30 mg/L TSS ≤ 30 mg/L (gals/sq ft/day)
0 to less than 10	0.7	1.2
10 to less than 30	0.6	0.9
30 to less than 45	0.5	0.7
45 to less than 60	0.3	0.5
60 to 120	0.2	0.3
greater than 120	0.0	0.0

Note: > means greater than  
≤ means less than or equal to

**Table 83.44-2**  
**Maximum Soil Application Rates Based Upon Morphological Soil Evaluation**  
(in gals./sq. ft./day)

Soil Characteristics			Maximum Monthly Average			
Texture <sup>d</sup>	Structure <sup>e</sup>		BOD <sub>5</sub> 30 ≤ 220mg/L TSS > 30 ≤ 150mg/L		BOD <sub>5</sub> ≤ 30 mg/L TSS ≤ 30 mg/L <sup>c</sup>	
	Shape	Grade				
COS, S, LCOS, LS	---	0	0.7 <sup>a</sup>	0.5 <sup>b,c</sup>	1.6 <sup>a</sup>	0.5 <sup>b</sup>
FS, LFS	---	0	0.5		1.0	
VFS, LVFS	---	0	0.4		0.6	
COSL, SL	---	0M	0.2		0.6	
	PL	1	0.4		0.6	
		2, 3	0.0		0.2	
	PR, BK, GR	1	0.4		0.7	
2, 3		0.6		1.0		
FSL, VFSL	---	0M	0.2		0.5	
	PL	2, 3	0.0		0.2	
	PL, PR, BK, GR	1	0.2		0.6	
	PR, BK, GR	2, 3	0.4		0.8	
L	---	0M	0.2		0.5	
	PL	2, 3	0.0		0.2	
	PL, PR, BK, GR	1	0.4		0.6	
	PR, BK, GR	2, 3	0.6		0.8	
SIL	---	0M	0.0		0.2	
	PL	2, 3	0.0		0.2	
	PL, PR, BK, GR	1	0.4 <sup>c</sup>		0.6	
	PR, BK, GR	2, 3	0.6		0.8	
SI	---	---	0.0		0.0	
SCL, CL, SICL	---	0M	0.0		0.0	
	PL	1, 2, 3	0.0		0.2	
	PR, BK, GR	1	0.2		0.3	
		2, 3	0.4		0.6	
SC, C, SIC	---	0M	0.0		0.0	
	PL	1, 2, 3	0.0		0.0	
	PR, BK, GR	1	0.0		0.0	
		2, 3	0.2		0.3	

Note a: With ≤60% rock fragments

Note b: With >60 to <90% rock fragments

Note c: Requires pressure distribution under sub. (5) (a)

Note d:

COS - Coarse Sand	LVFS - Loamy Very Fine Sand
S-Sand	COSL - Coarse Sandy Loam
LCOS - Loamy Coarse Sand	SL - Sandy Loam
LS - Loamy Sand	FSL - Fine Sandy Loam
FS - Fine Sand	VFSL - Very Fine Sandy Loam
LFS - Loamy Fine Sand	L - Loam
VFS - Very Fine Sand	SIL - Silt Loam
PL - Platy	0 - Structureless
PR - Prismatic	1 - Weak
BK - Blocky	2 - Moderate
GR - Granular	3 - Strong
M - Massive	

S1 - Silt  
SCL - Sandy Clay Loam  
CL - Clay Loam  
SICL - Silty Clay Loam  
SC - Sandy Clay  
C - Clay  
SIC - Silty Clay

**Table 83.44-3**  
**Minimum Depth of Unsaturated Soil for Treatment Purposes<sup>a</sup>**  
**(in inches)**

Soil Characteristics	Influent Quality and Percent Coarse Fragments					
	Fecal Coliform >10 <sup>4</sup> cfu/100mL			Fecal Coliform ≤10 <sup>4</sup> cfu/100mL <sup>b</sup>		
	≤35%	>35 to ≤60%	>60 to ≤90% <sup>b,c</sup>	≤35%	>35 to ≤60%	>60 to ≤90% <sup>c</sup>
COS, S, LCOS, LS	36	60	60	24	36	60
FS, VFS, LFS, LVFS	36			24		
COSL, SL	36			24		
FSL, VFSL	36			24		
L	36			24		
SIL	36			24		
SI	36			24		
SCL, CL, SICL	36			24		
SC, C, SIC	36			24		

Note a: Influent quality as per s. Comm 83.44 (2)

Note b: Requires pressure distribution under sub. (5) (a)

Note c: All coarse fragment voids must be filled with fine earth

Note d:

COS - Coarse Sand	LVFS - Loamy Very Fine Sand
S-Sand	COSL - Coarse Sandy Loam
LCOS - Loamy Coarse Sand	SL - Sandy Loam
LS - Loamy Sand	FSL - Fine Sandy Loam
FS - Fine Sand	VFSL - Very Fine Sandy Loam
LFS - Loamy Fine Sand	L - Loam
VFS - Very Fine Sand	SIL - Silt Loam

SI - Silt
SCL - Sandy Clay Loam
CL - Clay Loam
SICL - Silty Clay Loam
SC - Sandy Clay
C - Clay
SIC - Silty Clay

**(6) ORIENTATION.** (a) 1. The infiltrative surface of a distribution cell within a POWTS treatment or dispersal component consisting in part of in situ soil and located in fill material above original grade shall be level.

2. The longest dimension of a POWTS treatment or dispersal component consisting in part of in situ soil shall be oriented along the surface contour of the component site location unless otherwise approved by the department.

Note: See appendix for an illustration depicting a distribution cell.

(b) The infiltrative surface of a distribution cell within a POWTS treatment or dispersal component consisting in part of in situ soil and located below the surface of the original grade shall be level.

(c) POWTS treatment or dispersal components consisting in part of in situ soil shall be so located as to minimize the infiltration of storm water into the component.

**(7) GEOMETRY.** The geometry of a subsurface treatment or dispersal component consisting in part of the in situ soil shall take into account linear loading rates that are based on soil texture, structure, consistence and distance to seasonal soil saturation and restrictive soil horizons.

History: Cr. Register, April, 2000, No. 532, eff. 7-1-00; CR 02-129: (3) (b) and (4) (c), r. and recr. (5) (a) and Tables 83.44-2 and 83.44-3 Register January 2004 No. 577, eff. 2-1-04.

**Comm 83.45 Installation.** **(1) GENERAL.** A POWTS shall be constructed and installed in such a manner to hold waste water or reduce the contaminant load and disperse the flow of wastewater in accordance with this subchapter and the plan approval under s. Comm 83.22.

**(2) FROZEN SOIL.** POWTS treatment and dispersal components consisting in part of in situ soil may not be installed if the soil is frozen at the infiltrative surface of the component.

**(3) SNOW COVER.** Snow cover shall be removed before excavating or installing POWTS treatment and dispersal components consisting in part of in situ soil.

**(4) MOISTURE.** The soil moisture content for a POWTS treatment or dispersal component consisting in part of in situ soil shall be evaluated immediately prior to installation of the component. If the soil at the infiltrative surface can be rolled into a ¼-inch wire, the installation may not proceed.

**(5) BEDDING.** All vessels and pipes of a POWTS shall be bedded in accordance with a product approval under s. Comm 84.10 or a plan approval under s. Comm 83.22.

**(6) FLOOD FRINGE.** (a) All POWTS treatment tanks, holding and dispersal tanks that are located in flood fringe areas shall be made and maintained watertight to prevent infiltration.

(b) Vent pipes and observation pipes serving POWTS components that are located in flood fringe areas shall terminate at least 2 feet above regional flood levels.

Note: See s. Comm 83.43 (8) (g) relative to anchoring provisions.  
 History: Cr. Register, April, 2000, No. 532, eff. 7-1-00.

**Subchapter V — Management**

**Comm 83.50 Purpose.** The purpose of this subchapter is to:

**(1)** Establish monitoring and maintenance requirements for POWTS in order to ensure that POWTS will operate as designed and thereby protect the public health and the waters of the state; and

**(2)** Provide the department with data by which to make regulatory decisions.

History: Cr. Register, April, 2000, No. 532, eff. 7-1-00.



**Comm 83.51 Principles.** (1) A POWTS, including a POWTS existing prior to July 1, 2000, shall be maintained at all times so as not to create a human health hazard.

(2) When upon inspection of a POWTS, including a POWTS existing prior to July 1, 2000, any part of the system that is found to be defective in conformance with the applicable provisions of this chapter, the installation or modification plan, or the approvals, the part shall be repaired, renovated, replaced or removed.

**Note:** Section Comm 87.60 (5) (b) 4. also establishes management and maintenance requirements for a POWTS that is located in a governmental unit which participates in the replacement and rehabilitation program under s. 145.245, Stats.

**History:** Cr. Register, April, 2000, No. 532, eff. 7-1-00.

**Comm 83.52 Responsibilities.** (1) (a) The owner of a POWTS shall be responsible for ensuring that the operation and maintenance of the POWTS occurs in accordance with this chapter and the approved management plan under s. Comm 83.54 (1).

(b) The owner of a POWTS existing prior July 1, 2000, shall be responsible for ensuring that the maintenance of the POWTS occurs in accordance with s. Comm 83.54 (4).

(c) 1. The owner of a POWTS, including a POWTS existing prior to July 1, 2000, shall maintain a maintenance or service contract with a POWTS maintainer or a business utilizing a POWTS maintainer for the POWTS as long as the POWTS is utilized and, if the management plan for the POWTS under s. Comm 83.54 (1) involves one or more of the following:

a. Evaluating or monitoring any part of the system at an interval of 12 months or less.

b. Maintaining any part of the system at an interval of 12 months or less.

2. The owner of a POWTS, including a POWTS existing prior to July 1, 2000, shall maintain a maintenance or service contract with a certified septage servicing operator under ch. NR 114 for the POWTS as long as the POWTS is utilized and, if the management plan for the POWTS under s. Comm 83.54 (1) involves the servicing of any holding, treatment or dispersal component at an interval of 12 months or less.

(2) A POWTS, including a POWTS existing prior to July 1, 2000, that is not maintained in accordance with the approved management plan or as required under s. Comm 83.54 (4) shall be considered a human health hazard.

(3) The activities relating to evaluating and monitoring POWTS components after the initial installation of the POWTS in accordance with an approved management plan shall be conducted by a person who holds a registration issued by the department as a registered POWTS maintainer

**Note:** See s. Comm 5.36 concerning the application and qualification requirements to become a registered POWTS maintainer.

**History:** Cr. Register, April, 2000, No. 532, eff. 7-1-00; CR 02-129; am. (3) Register January 2004 No. 577, eff. 2-1-04.

**Comm 83.53 General.** (1) No product for chemical or physical restoration or chemical or physical procedures for POWTS, including a POWTS existing prior to July 1, 2000, may be used unless approved by the department in accordance with ss. Comm 84.10 and 84.13.

(2) Nothing in this subchapter shall limit a governmental unit's authority and power in establishing a mandatory POWTS maintenance program, including management or maintenance undertaken by the governmental unit.

**History:** Cr. Register, April, 2000, No. 532, eff. 7-1-00.

**Comm 83.54 Management requirements.** (1) **MANAGEMENT PLAN.** (a) The management plan for each POWTS shall include information and procedures for maintaining the POWTS to operate and function within the standards of this chapter and as designed and approved.

(b) The management plan for a POWTS shall be a part of the plan submittal under s. Comm 83.22 or 84.10.

(c) The management plan for POWTS shall specify all necessary maintenance and servicing information which may include, but is not limited to all of the following:

1. Accumulated solids or byproduct removal requirements.

2. Influent quantities and qualities and effluent quantities and qualities.

3. Metering, sampling and monitoring schedules and requirements.

4. Load and rest schedules.

5. Servicing frequency requirements.

6. Installation and inspection checklists.

7. Evaluation, monitoring and maintenance schedules for mechanical POWTS components.

8. Start up and shutdown procedures.

9. Procedure for abandonment.

(d) If the owner of the POWTS wishes to operate or maintain a POWTS differently than that specified in the approved management plan, a written request for approval to amend the management plan shall be submitted to the agency that initially reviewed the installation plan under s. Comm 83.22.

(e) The management plan for a POWTS shall specifically address the servicing mechanics of an aerobic or anaerobic treatment tank or a holding tank where either of the following conditions exist:

1. The bottom of the tank is located more than 15 feet below the elevation where the servicing pad is located.

2. The bottom of the tank is located more than 150 feet horizontally from where the servicing pad is located.

(2) **METERING AND MONITORING.** (a) **General.** The management plan specified in sub. (1) shall include the metering or monitoring of POWTS influent or effluent as specified in this subsection.

(b) **Department option.** The department may require the metering or monitoring of any POWTS to evaluate the operation of the POWTS.

(c) **Governmental unit option.** A governmental unit may require the metering or monitoring of a POWTS holding component as part of a maintenance and monitoring tracking program.

(d) **Metering influent flows.** 1. When and where the metering of a POWTS is required, influent flows to POWTS shall be metered by one of the following methods:

a. Installing event counters and elapsed time meters.

b. Installing water meters to meter the water distribution system flow to the POWTS.

c. Metering wastewater flow from all parts of the plumbing system discharging to the POWTS.

d. Metering the water distribution system and metering exterior hydrant use, except as provided in subd. 2.

2. Where meters are installed on water distribution systems existing prior to July 1, 2000, the entire water distribution system may be metered and the exterior hydrant usage estimated and subtracted from the total flow to meet the requirements of this paragraph.

(e) **Monitoring influent and effluent loads.** 1. When and where the monitoring of groundwater is required, groundwater monitoring wells constructed in accordance with ch. NR 141 shall be utilized.

2. When influent or effluent contaminants are to be monitored, samples shall be collected in accordance with the requirements of the approved management plan or, where no procedures are specified, in accordance with published sampling procedures accepted by the department.

**Note:** Acceptable sampling procedures include those contained in the following sources:

"Procedures Manual for Ground Water Monitoring at Solid Waste Disposal Sites," EPA SW-611, Office of Water and Waste Management, U. S. Environmental Protection Agency, December 1980, Washington, D. C.

"Techniques of Water Resources Investigations of the United States Geological Survey, Guidelines for Collection and Field Analysis of Ground Water Samples for Selected Unstable Constituents," Book I, Chapter D2, U.S. Geological Survey, Washington, D. C.

"Procedures for the Collection of Representative Water Quality Data from Monitoring Wells," Cooperative Groundwater Report 7, Illinois State Water Survey, 1981, Champaign, Illinois.

"Manual of Ground Water Sampling Procedures," NWWA/EPA Series, Robert S. Kerr Environmental Research Laboratory, 1981, Ada, Oklahoma.

"Groundwater Sampling Procedures Guidelines," Wisconsin DNR, PUBL-WR-153, February 1987.

"Groundwater Sampling Procedures Field Manual," Wisconsin DNR, PUBL-WR-168, September 1987.

3. All groundwater samples collected to evaluate influent or effluent quality, except samples collected for total coliform bacteria analysis and the field analyses for pH, specific conductance and temperature, shall be analyzed by a laboratory certified under s. 299.11, Stats., and rules adopted under that section.

4. The results of the analysis required under subd. 2. shall be maintained and reported as required in the approved management plan and in accordance with s. Comm 83.55 (1) (a).

(3) **SERVICING REQUIREMENTS.** (a) The management plan specified in sub. (1) shall reflect the servicing schedules of POWTS components as specified in this subsection

(b) The servicing frequency of an anaerobic treatment tank for a POWTS shall occur at least when the combined sludge and scum volume equals 1/3 of the tank volume.

(c) The servicing frequency of a holding tank for a POWTS, except for camping unit transfer containers, shall occur at least when the wastewater of the tank reaches a level of one foot below the inlet invert of the tank.

**Note:** The servicing of POWTS holding and treatment components, including septic tanks and holding tanks, is required to be performed by licensed pumpers under chs. NR 113 and NR 114.

(4) **EXISTING POWTS.** (a) The servicing frequency of an anaerobic treatment tank for a POWTS existing prior to July 1, 2000, shall occur at least when the combined sludge and scum volume equals 1/3 of the tank volume.

(b) The servicing of a holding tank for a POWTS existing prior to July 1, 2000, except for camping unit transfer containers, shall occur at least when the wastewater of the tank reaches a level of one foot below the inlet invert of the tank.

(c) The servicing or maintenance of POWTS treatment components other than those under pars. (a) and (b) existing prior to July 1, 2000, shall be provided in accordance with the requirements specified by the manufacturer or designer of the component.

(d) 1. A POWTS that exists prior to July 1, 2000, and that utilizes a treatment or dispersal component consisting in part of in situ soil shall be visually inspected at least once every 3 years to determine whether wastewater or effluent from the POWTS is ponding on the surface of the ground.

2. The inspection required by subd. 1. shall be performed by one of the following:

- a. A licensed master plumber.
- b. A licensed master plumber-restricted service.
- c. A certified POWTS inspector.
- d. A certified septage servicing operator under ch. NR 114.
- e. A registered POWTS maintainer.

**History:** Cr. Register, April, 2000, No. 532, eff. 7-1-00; CR 02-129: cr. (1) (e) and (4) (d) 2. e., r. and recr. (2) (c), am. (2) (d) 1. (intro.) Register January 2004 No. 577, eff. 2-1-04.

**Comm 83.55 Reporting requirements.** (1) (a) The owner of a POWTS or the owner's agent shall report to the governmental unit or designated agent at the completion of each inspection, maintenance or servicing event specified in the approved management plan, except for camping unit transfer containers.

(b) The owner of a POWTS existing prior to July 1, 2000, or the owner's agent shall report to the governmental unit or designated agent at the completion of each inspection, maintenance or

servicing event required under s. Comm 83.54 (4), except for camping unit transfer containers.

(2) The inspection, maintenance and servicing reports required under sub. (1) shall be submitted to the governmental unit or designated agent in accordance with all of the following:

(a) In a manner specified by the governmental unit or designated agent.

(b) Within 30 calendar days from the date of inspection, maintenance or servicing.

(c) By the owner or the owner's agent.

(3) The inspection, maintenance and servicing reports required under sub. (1) shall include the following information:

(a) A POWTS identifying number.

(b) The location of the POWTS.

(c) The date of inspection, maintenance or servicing.

(d) The license, certification or registration number of the individual performing the inspection, maintenance or servicing.

(e) Other information required by the approved management plan.

(4) The department or designated agent may require verification of any information contained in a inspection, maintenance and servicing report.

**Note:** This subsection does not require the maintaining of test data which is collected voluntarily and which is not being collected to determine compliance with this chapter.

(5) (a) The governmental unit or designated agent shall maintain records relating to the inspection, maintenance and servicing of POWTS as specified in this section for a period of not less than 6 years.

(b) Upon request by a governmental unit and the agreement of the department, the governmental unit may delegate to the department the responsibility to maintain records relating to the inspection, maintenance and servicing of POWTS as specified in this section.

**History:** Cr. Register, April, 2000, No. 532, eff. 7-1-00; CR 02-129: am. (1), (2), and (5) Register January 2004 No. 577, eff. 2-1-04.

## Subchapter VI — Recognized Methods and Technologies

**Comm 83.60 Purpose.** (1) This subchapter identifies specific types of methods and technologies that have been recognized by the department under the voluntary product approval process in s. Comm 84.10 (3) to conform with subchs. IV and V and that may be utilized in the design of POWTS for a specific project.

**Note:** Subsection Comm 84.10 (3) delineates a process for the voluntary submittal of specific methods and technologies that are proposed to be utilized as POWTS holding, treatment or dispersal components and for the department's evaluation of such submittals. Methods and technologies recognized under this process may be utilized in any POWTS within the specifications and parameters of the method or technology. Methods and technologies recognized under this process do not require the submittal of data at the time of plan review and approval process under s. Comm 83.22 to substantiate the performance of the specific method or technology.

(2) This subchapter does not limit the use of other methods and technologies for POWTS or POWTS components the performance of which has been recognized under the plan review and approval process of s. Comm 83.22 or the voluntary product approval process of s. Comm 84.10 (3) or both.

**Note:** Section Comm 83.22 delineates the process for the submittal of a plan for a POWTS design to be utilized for a specific project at a specific site. Under this section methods and technologies for POWTS holding, treatment or dispersal components that have not been recognized under s. Comm 84.10 (3), require the submittal to the department of data or information to substantiate performance claims. The approval of a POWTS plan by the department under this section covers only a specific project at a specific site, and does not constitute the recognition of a method or technology for other projects or sites.

**History:** Cr. Register, April, 2000, No. 532, eff. 7-1-00.

**Comm 83.61 Acceptable methods and technologies.** Pursuant to s. Comm 84.10 (3), the department recognizes at least the following methods and technologies to be utilized in the design of POWTS:

(1) Pressure Distribution Component Manual for Private Onsite Wastewater Treatment Systems, June 11, 1999.

(2) At-Grade Component Manual Using a Pressure Distribution System for Private Onsite Wastewater Systems, June 11, 1999.

(3) Mound Component Manual for Septic Tank Effluent for Private Onsite Wastewater Systems, June 11, 1999.

(4) In-Ground Soil Absorption Component Manual for Private Onsite Wastewater Systems, June 11, 1999.

(5) Holding Tank Component Manual for Private Onsite Wastewater Systems, June 11, 1999.

(6) Single Pass Sand Filter Component Manual for Private Onsite Wastewater Systems, June 25, 1999.

(7) Recirculating Sand Filter Component Manual for Private Onsite Wastewater Systems, June 25, 1999.

(8) Split Bed Recirculating Sand Filter System Component Manual for Private Onsite Wastewater Treatment Systems, June 25, 1999.

(9) Drip-Line Effluent Dispersal Component Manual for Private Onsite Wastewater Treatment Systems, June 24, 1999.

**Note:** See appendix for information on obtaining copies of the above manuals from the department. Subsection Comm 84.10 (3) (e) delineates the circumstances under which additional methods or technologies will be specifically enumerated under this section, s. Comm 83.61.

**History:** Cr. Register, April, 2000, No. 532, eff. 7-1-00; CR 02-129: am. (4) Register January 2004 No. 577, eff. 2-1-04.

**Comm 83.62 Parameters for using acceptable methods and technologies.** When a design of a POWTS for a specific project utilizes a method or technology recognized under s. Comm 84.10 (3), a deviation from the specifications and limitations relative to the installation and maintenance of that method or technology shall constitute a violation of this chapter.

**History:** Cr. Register, April, 2000, No. 532, eff. 7-1-00.

### Subchapter VII — Department Performance Monitoring

**Comm 83.70 Purpose.** (1) To address the desire for an ongoing source of information on the performance of POWTS system designs, the department shall maintain an ongoing performance-monitoring program for the various POWTS methods and technologies. The monitoring program shall be in addition to the periodic inspection and monitoring of POWTS under subch. V. The monitoring program shall be coordinated by the department in conjunction with the ongoing POWTS experimental and research program.

(2) The purpose of the performance monitoring program is to:

(a) Provide additional information on the long-term performance of the various POWTS methods and technologies, to confirm their reliability, and to provide data for improvements; and

(b) Monitor the various methods and technologies relative to long-term compliance with the groundwater standards.

**History:** Cr. Register, April, 2000, No. 532, eff. 7-1-00.

**Comm 83.71 Department procedures.** (1) Both currently installed POWTS and newly installed POWTS may be included in the performance monitoring program conducted by the department.

(2) The department may include both the performance of individual POWTS treatment components as well as the output of components at the edge of the design treatment zone as part of the monitoring program.

(3) The department shall support the performance-monitoring program from Wisconsin Fund allocations and program revenue funds generated from POWTS plan review and sanitary permits. If funds for this purpose become available from other sources, those funds may be used to support the monitoring program.

(4) The department shall utilize the technical advisory committee assembled under s. Comm 84.10 (3) (c) 2. to advise the department on the performance-monitoring program. The committee shall advise the department in at least the following areas:

(a) Development of performance monitoring protocols.

(b) Selection of the POWTS methods and technologies to be monitored.

(c) Identification of funding sources.

(d) The interpretation of the results of the monitoring program.

(5) The decision by the department on the number, types and locations of methods and technologies to be monitored shall take into consideration at least the following factors:

(a) The availability of other scientific data on the performance of a specific method or technology.

(b) The number times of each method or technology may be utilized annually.

(c) The likelihood that the method or technology will be adapted for soil and site conditions not previously utilized.

(d) The availability of funds.

(e) The risk factors associated with public health concerns and groundwater and surface water standards.

(6) The initial performance monitoring program undertaken by the department shall emphasize at least the following two circumstances:

(a) Monitoring where there is a high density of systems.

**Note:** The initial focus would be on subdivisions with lots of 1.5 acres or less.

(b) Monitoring where the depth of suitable in situ soil is near the minimum 6 inches specified under s. Comm 83.44 (3) (b) 1.

(7) (a) The department shall prepare an annual written report of performance-monitoring activities undertaken and the results of those activities.

(b) The report under par. (b) shall be prepared annually and provided to the groundwater coordinating council assembled under s. 160.50, Stats.

(c) The department shall prepare the first report no later than December 31, 2001.

**History:** Cr. Register, April, 2000, No. 532, eff. 7-1-00.



**Chapter Comm 83****APPENDIX**

---

The material and information contained in this appendix is for clarification purposes only. Appendix material and information are numbered to correspond to the rule number as it appears in the text of the code. Material and information included in this appendix is subject to change without notice, including names, addresses, phone numbers and forms, and reflects information known at the time of publication.

**A-83.21 (2) APPLICATION.** The specific format of a sanitary permit application is specified by the department and may change depending on the data tracking needs of the department. The uniform application form issued by the department is to be used by all permit issuing agents. It may consist of a paper or electronic format, or both. The sanitary permit application form will require the applicant to report information pertinent to the ownership, use, location, system type, maintenance schedule, and responsible installer. Additionally, plans and specifications for the project must also be submitted with, and are part of, the permit application. Fees for the sanitary permit are based on a statutory minimum as cited in s. 145.19(2), Wis. Stats. and any additional costs levied by the issuing agent.

**A-83.21 (3) PROCESSING.** The state sanitary permit is issued when evidence and documentation is presented by the owner of the property that minimum code standards have been or will be met.



**SANITARY PERMIT APPLICATION**

In accord with Comm 83.05, Wis. Adm. Code

Safety and Buildings Division  
201 W. Washington Avenue  
P O Box 7162  
Madison, WI 53707-7162

- Attach complete plans (to the county copy only) for the system, on paper not less than 8 1/2 x 11 inches in size.
- See reverse side for instructions for completing this application

Personal information you provide may be used for secondary purposes [Privacy Law, s. 15.04 (1)(m)].

County
State Sanitary Permit Number
<input type="checkbox"/> Check if revision to previous application
State Plan Review Transaction Number

**I. APPLICATION INFORMATION - PLEASE PRINT ALL INFORMATION**

Property Owner Name		Property Location 1/4 1/4, S T, N, R E (or) W	
Property Owner's Mailing Address		Lot Number	Block Number
City, State	Zip Code	Phone Number ( )	Subdivision Name or CSM Number

**II. TYPE OF BUILDING:** (check one)  State Owned  
 Public  1 or 2 Family Dwelling - No. of bedrooms \_\_\_\_\_

<input type="checkbox"/> City <input type="checkbox"/> Village <input type="checkbox"/> Town OF	Nearest Road
---	--------------

**III. BUILDING USE:** (If building type is public, check all that apply)

1 <input type="checkbox"/> Apartment / Condo	6 <input type="checkbox"/> Medical Facility / Nursing Home	10 <input type="checkbox"/> Outdoor Recreational Facility
2 <input type="checkbox"/> Assembly Hall	7 <input type="checkbox"/> Merchandise: Sales / Repairs	11 <input type="checkbox"/> Restaurant / Bar / Dining
3 <input type="checkbox"/> Campground	8 <input type="checkbox"/> Mobile Home Park	12 <input type="checkbox"/> Service Station / Car Wash
4 <input type="checkbox"/> Church / School	9 <input type="checkbox"/> Office / Factory	13 <input type="checkbox"/> Other: specify _____
5 <input type="checkbox"/> Hotel / Motel		

Parcel Tax Number(s)

**IV. TYPE OF PERMIT:** (Check only one box on line A. Check box on line B, if applicable)

A) 1.  New System    2.  Replacement System    3.  Replacement of Tank Only    4.  Reconnection of Existing System    5.  Repair of an Existing System

B)  A Sanitary Permit was previously issued. Permit Number \_\_\_\_\_ Date Issued \_\_\_\_\_

**V. TYPE OF SYSTEM:** (Check only one)

<i>Non-Pressurized Distribution</i>	<i>Pressurized Distribution</i>	<i>Experimental</i>	<i>Other</i>
11 <input type="checkbox"/> Seepage Bed	21 <input type="checkbox"/> Mound	30 <input type="checkbox"/> Specify Type _____	41 <input type="checkbox"/> Holding Tank
12 <input type="checkbox"/> Seepage Trench	22 <input type="checkbox"/> In-Ground Pressure		42 <input type="checkbox"/> Pit Privy
13 <input type="checkbox"/> Seepage Pit			43 <input type="checkbox"/> Vault Privy
14 <input type="checkbox"/> System-In-Fill			

**VI. ABSORPTION SYSTEM INFORMATION:**

1. Gallons Per Day	2. Absorp. Area Required (sq. ft.)	3. Absorp. Area Proposed (sq. ft.)	4. Loading Rate (Gals/day/sq. ft.)	5. Perc. Rate (Min./inch)	6. System Elev. Feet	7. Final Grade Elevation Feet
--------------------	------------------------------------	------------------------------------	------------------------------------	---------------------------	----------------------	-------------------------------

**VII. TANK INFORMATION**

	Capacity in gallons		Total Gallons	# of Tanks	Manufacturer's Name	Prefab. Concrete	Site Constructed	Steel	Fiber-glass	Plastic	Exper. App.
	New Tanks	Existing Tanks									
Septic Tank or Holding Tank						<input type="checkbox"/>	<input type="checkbox"/>	<input type="checkbox"/>	<input type="checkbox"/>	<input type="checkbox"/>	<input type="checkbox"/>
Lift Pump Tank /Siphon Chamber						<input type="checkbox"/>	<input type="checkbox"/>	<input type="checkbox"/>	<input type="checkbox"/>	<input type="checkbox"/>	<input type="checkbox"/>

**VIII. RESPONSIBILITY STATEMENT**

I, the undersigned, assume responsibility for installation of the onsite sewage system shown on the attached plans.

Plumber's Name: (Print)	Plumber's Signature: (No Stamps)	MP/MPSW No.:	Business Phone Number:
-------------------------	----------------------------------	--------------	------------------------

Plumber's Address (Street, City, State, Zip Code): \_\_\_\_\_

**IX. COUNTY / DEPARTMENT USE ONLY**

<input type="checkbox"/> Approved	<input type="checkbox"/> Disapproved <input type="checkbox"/> Owner Given Initial Adverse Determination	Sanitary Permit Fee (Includes Groundwater Surcharge Fee)	Date Issued	Issuing Agent Signature (No Stamps)
-----------------------------------	--	--	-------------	-------------------------------------

**X. CONDITIONS OF APPROVAL / REASONS FOR DISAPPROVAL:**

SBD-6398 (R.12/99)

DISTRIBUTION: Original to County, One copy To: Safety & Buildings Division, Owner, Plumber

PLB 68

COUNTY

# SANITARY PERMIT

OWNER \_\_\_\_\_

PLUMBER \_\_\_\_\_ LIC. # \_\_\_\_\_

TOWN OF \_\_\_\_\_ LOCATED \_\_\_\_\_

SEC \_\_\_\_\_ T \_\_\_\_\_ N/R \_\_\_\_\_

AND/OR LOT \_\_\_\_\_ BLOCK \_\_\_\_\_

\_\_\_\_\_ SUBDIVISION

AUTHORIZED ISSUING OFFICER - DATE \_\_\_\_\_

THIS PERMIT EXPIRES \_\_\_\_\_ UNLESS RENEWED BEFORE THAT DATE

(TWO YEARS FROM ORIGINAL DATE OF ISSUANCE)

# POST IN PLAIN VIEW

VISIBLE FROM THE ROAD FRONTING THE LOT  
DURING CONSTRUCTION

SBD-6499(R, 04/96)

### CHAPTER 145.135 WISCONSIN STATUTES

- (a) The purpose of the sanitary permit is to allow installation of the private sewage system described in the application for permit.
  - (b) The approval of the sanitary permit is based on regulations in force on the date of issue.
  - (c) The sanitary permit is valid for 2 years from original date of issuance and may be renewed for similar periods thereafter. Application for renewal shall be made through the county and shall comply with regulations in effect at the time.
  - (d) Changed regulations will not impair the validity of a sanitary permit until the time of renewal.
  - (e) Renewal of the sanitary permit will be based on regulations in force at the time renewal is sought. Changed regulations may impede renewal.
  - (f) The sanitary permit is transferable. A sanitary permit transfer shall be obtained from the county authority.
- \* If you wish to renew the permit, or transfer ownership of the permit, please contact the county authority.

Chapter 145 Wisconsin Statutes provides some direction as to the issuance of sanitary permits as follows:

**145.135 Sanitary permits.**

(1) **VALIDITY.** In this section, "sanitary permit" means a permit issued by the department or any governmental unit responsible for the regulation of private sewage systems for the installation of a private sewage system. No person may install a private sewage system unless the owner of the property on which the private sewage system is to be installed holds a valid sanitary permit. A sanitary permit is valid for 2 years from the date of issue and renewable for similar periods thereafter. A governmental unit responsible for the regulation of private sewage systems may not charge more than one fee for a sanitary permit or the renewal of a sanitary permit in any 12-month period. A sanitary permit shall remain valid to the end of the established period, notwithstanding any change in the state plumbing code or in any private sewage system ordinance during that period. A sanitary permit may be transferred from the holder to a subsequent owner of the land, except that the subsequent owner must obtain a new copy of the sanitary permit from the issuing agent. The results of any percolation test or other test relating to the disposal of liquid domestic wastes into the soil shall be retained by the governmental unit responsible for the regulation of private sewage systems where the property is located. The governmental unit responsible for the regulation of private sewage systems shall make the test results available to an applicant for a sanitary permit and shall accept the test results as the basis for a sanitary permit application unless the soil at the test site is altered to the extent that a new soil test is necessary.

(2) **NOTICE.** A sanitary permit shall include a notice displayed conspicuously and separately on the permit form, to inform the permit holder that:

(a) The purpose of the sanitary permit is to allow installation of the private sewage system described in the permit.

(b) The approval of the sanitary permit is based on regulations in force on the date of approval.

(c) The sanitary permit is valid and may be renewed for a specified period.

(d) Changed regulations will not impair the validity of a sanitary permit.

(e) Renewal of the sanitary permit will be based on regulations in force at the time renewal is sought, and that changed regulations may impede renewal.

(f) The sanitary permit is transferable.

**145.19 Sanitary permit.**

(1) **REQUIREMENT; INFORMATION; FORMS.** No septic tank may be purchased and no private sewage system may be installed unless the owner of the property on which the private sewage system is to be installed holds a valid sanitary permit from the governmental unit responsible for the regulation of private sewage systems in which the property is located. The department shall prescribe the information to be included in the sanitary permit and furnish sanitary permit forms to the governmental unit. The applicant shall submit the completed sanitary permit to the governmental unit. The governmental unit shall approve or disapprove the sanitary permit according to the rules promulgated by the department under this chapter. No person may sell at retail, as defined under s. 100.201 (1) (d), a septic tank for installation in this state unless the purchaser holds a valid sanitary permit issued under this section.

(2) **FEE.** No fee for a sanitary permit may be less than \$61, or the amount determined under department rule. The governing body for the governmental unit responsible for the regulation of private sewage systems may establish a fee for a sanitary permit which is more than \$61, or the amount determined under department rule.

(3) **COPY OF PERMIT FORWARDED TO THE DEPARTMENT.** The governmental unit responsible for the regulation of private sewage systems shall forward a copy of each valid sanitary permit and \$20, or the amount determined under department rule, of the fee to the department within 90 days after the permit is issued.

(4) **USE OF FEE.** The portion of this fee retained by the governmental unit responsible for the regulation of private sewage systems shall be used for the administration of private sewage system programs.

(5) **FEE ADJUSTMENT.** The department, by rule promulgated under ch. 227, may adjust the minimum permit fee under sub. (2) and the fee portion forwarded under sub. (3).

(6) **GROUNDWATER FEE.** In addition to the fee under sub. (2), the governmental unit responsible for the regulation of private sewage systems shall collect a groundwater fee of \$25 for each sanitary permit. The governmental unit shall forward this fee to the department together with the copy of the sanitary permit and the fee under sub. (3). The moneys collected under this subsection shall be credited to the environmental fund for environmental management.

**A-83.21 (6) RENEWALS.** Sanitary permit renewals are completed in compliance with s.145.135 (1) and 145.135 (2) (e), Wis. Stats. A completed sanitary permit renewal application form must be submitted to the local permit issuing agent.



State of Wisconsin  
 Department of Commerce  
 Safety and Buildings Division  
 Integrated Services Bureau

# SANITARY PERMIT Transfer/Renewal

County	
Uniform Permit Number	

Personal information you provide may be used for secondary purposes [Privacy Law, s. 15.04 (1)(m)].

Permit Renewal Date	Permit Transfer Date	Original Permit Issuance Date	State Regulated Object
Property Location 1/4 1/4 S T N.R E (or) W	<input type="checkbox"/> Town <input type="checkbox"/> Village <input type="checkbox"/> City of	Subdivision Name	Nearest Road, Lake or Landmark
Lot Number	Block Number		

**PREVIOUS SANITARY PERMIT HOLDER – IF CHANGED: SANITARY PERMIT TRANSFERRED TO**

Name (Please Print)	Signature	Name (Please Print)	Phone Number
Address	Phone Number ( )	Street Address, City, State, Zip Code	( )

I, the undersigned, assume responsibility for installation of the private sewage system that has been previously approved for this property.

Plumber Signature	Previous Plumber Name (if changed)
Plumber Address	Previous Plumber address
MP/MPRSW Number	MP/MPRSW Number
Phone Number ( )	Phone Number ( )

Issuing Agent Signature \_\_\_\_\_

Date Approved \_\_\_\_\_

SBD-6399 (R.4/99)

PLB 68-T

# COUNTY SANITARY PERMIT TRANSFER/RENEWAL

No. \_\_\_\_\_

OWNER \_\_\_\_\_

PLUMBER \_\_\_\_\_ LIC. # \_\_\_\_\_

TOWN OF \_\_\_\_\_ LOCATED \_\_\_\_\_

SEC \_\_\_\_\_ T \_\_\_\_\_ N:R \_\_\_\_\_

AND/OR LOT \_\_\_\_\_ BLOCK \_\_\_\_\_

SUBDIVISION \_\_\_\_\_

**CHAPTER 145.135 WISCONSIN STATUTES**

(a) The purpose of the sanitary permit is to allow installation of the private sewage system described in the application for permit.

(b) The approval of the sanitary permit is based on regulations in force on the date of issue.

(c) The sanitary permit is valid for 2 years from original date of issuance and may be renewed for similar periods thereafter. Application for renewal shall be made through the county and shall comply with regulations in effect at the time.

(d) Changed regulations will not impair the validity of a sanitary permit until the time of renewal.

(e) Renewal of the sanitary permit will be based on regulations in force at the time renewal is sought. Changed regulations may impede renewal.

(f) The sanitary permit is transferable. A sanitary permit transfer shall be obtained from the county authority.

\* If you wish to renew the permit, or transfer ownership of the permit, please contact the county authority.

\_\_\_\_\_ AUTHORIZED ISSUING OFFICER - DATE \_\_\_\_\_

THIS PERMIT EXPIRES \_\_\_\_\_ UNLESS RENEWED BEFORE THAT DATE

# POST IN PLAIN VIEW

VISIBLE FROM THE ROAD FRONTING THE LOT  
DURING CONSTRUCTION

DILHR-SSD-6494 (Rev. 04/92)

A-83.22 (2) PLANS AND SPECIFICATIONS. A POWTS plan review application form must be completed and submitted with a plan submittal. The application form is uniform state-wide and includes a worksheet to calculate the appropriate fees for the project.

 <p><b>Wisconsin</b> Department of Commerce</p>	<p><b>APPLICATION FOR REVIEW</b> -Complete all pages-</p>	<p><b>POWTS</b></p>
<p>Safety &amp; Buildings Division Bureau of Integrated Services</p>		<p>( ) Check if Confirmation is Desired: ( ) faxed, ( ) mailed ( ) Review in this office only</p>
<p><b>NOTE:</b> Personal information you provide may be used for secondary purposes [Privacy Law s. 15.04(1)(m), Stats.]</p>		
<p><b>1. Private Sewage Submittal System Type</b> ( ) Groundwater Monitoring ( ) Site Evaluation in lieu of Groundwater Monitoring  ( ) POWTS System ( ) At Grade ( ) Holding Tank ( ) Nonpressurized In-Ground-conventional ( ) Pressurized In-Ground-conventional ( ) Mound  ( ) Aerobic Treatment System ( ) Sand Filter     ___ single pass     ___ recirculating ( ) Constructed Wetland ( ) Other: _____</p> <p><b>Building Type (check one):</b> ( ) Dwelling, 1 or 2 family ( ) Commercial Building ( ) State-owned Building</p> <p>Gallons per Day _____</p>	<p><b>2. Type of Submittal:</b> ( ) New ( ) Revision, previous transaction number _____ ( ) Replacement ( ) Petition (attach form SBD-9890) ( ) Experiment, experiment approval number _____</p>	<p style="text-align: center;"><b>Confirmation of assignment to a reviewer.</b></p> <p>Transaction ID: _____ Previous Related Trans. ID: _____ Estimated Completion Date: _____ Assigned Reviewer: _____ Assigned Office: _____</p>
<p><b>3. Project Site Information - Fill in all known information.</b></p> <p>Commerce Site Number(if known) _____ Number &amp; Street: _____ Legal Description: _____ County _____ ( ) City ( ) Village ( ) Town of _____ Facility Name: (individual and/or business name of project) _____ Facility Address: (project address) _____ Zip _____ GIS _____</p>		
<p><b>4. After plans are reviewed, please: (check all that apply)</b>                  ___ Call when completed.                      ___ Mail plans to customer 1, 2, 3, 4                  ___ Requesting party will pick up              ___ Circle customer number from below.                  Other: _____</p>		
<p><b>5. Complete the following designer/owner/requesting information. Utilize the check boxes when designer, owner or requesting party is the same to avoid repeating information.</b></p>		
<p><b>Designer Information (Customer 1)</b></p>		<p><b>Requesting Party, if different than designer (Customer 3)</b></p>
First Name _____ Last Name _____ Customer Number _____	First Name _____ Last Name _____ Customer Number _____	
Company Name _____	Company Name _____	
Address _____	Address _____	
City _____ State _____ Zip+4 (9digits) _____	City _____ State _____ Zip+4 (9digits) _____	
Phone Number (area code) _____ Fax or Internet _____ cell phone _____	Phone Number (area code) _____ Fax or Internet _____	
Check others if applicable ( ) Owner ( ) Payer ( ) Requesting party	Check others if applicable ( ) Owner ( ) Payer	
<p><b>Owner Information (Customer 2)</b></p>		<p><b>Other Please specify (Customer 4)</b></p>
First Name _____ Last Name _____ Customer Number _____	First Name _____ Last Name _____ Customer Number _____	
Company Name _____	Company Name _____	
Address _____	Address _____	
City _____ State _____ Zip+4 (9digits) _____	City _____ State _____ Zip+4 (9digits) _____	
Phone Number (area code) _____ Fax or Internet _____	Phone Number (area code) _____ Fax or Internet _____	
Check others if applicable ( ) Payer	Check others if applicable ( ) Payer ( ) Other	
<p><b>MAKE CHECKS PAYABLE TO DEPT OF COMMERCE</b> Attach check here</p>	<p><b>TOTAL AMOUNT DUE</b>                      \$ _____ Review Code 7633</p>	

**6. Calculation of Fees Required (circle all that apply.)**

System Type (Include new and existing tanks)

Up to	5,000 gallon holding tank	.....	\$60.00	.....	_____
5,001	10,000 gallon holding tank	.....	\$100.00	.....	_____
Over	10,000 gallon holding tank	.....	\$150.00	.....	_____
Up to	1,500 gallon septic tank	.....	\$110.00	.....	_____
1,501 -	2,500 gallon septic tank	.....	\$120.00	.....	_____
2,501 -	5,000 gallon septic tank	.....	\$160.00	.....	_____
5,001 -	9,000 gallon septic tank	.....	\$200.00	.....	_____
9,001 -	15,000 gallon septic tank	.....	\$300.00	.....	_____
Over	15,000 gallon septic tank	.....	\$500.00	.....	_____
Up to	1,000 gallon dose chamber	.....	\$70.00	.....	_____
1,000 -	2,000 gallon dose chamber	.....	\$80.00	.....	_____
2,001 -	4,000 gallon dose chamber	.....	\$100.00	.....	_____
4,001 -	8,000 gallon dose chamber	.....	\$120.00	.....	_____
8,001 -	12,000 gallon dose chamber	.....	\$140.00	.....	_____
Over	12,000 gallon dose chamber	.....	\$160.00	.....	_____
Experimental System (additional one time fee)			\$300.00	.....	_____
Revisions to Approved Plan			\$60.00	.....	_____
Petitions for Variance	Setback	.....	\$100.00	.....	_____
(include Form	Site Evaluation	.....	\$225.00	.....	_____
SBD-9890)	(for specific system such as evaluating a site to define how placement of sand for a system in fill will affect wastewater or groundwater movement)				
	All Others	.....	\$225.00	.....	_____
	Revision	.....	\$75.00	.....	_____
Groundwater Monitoring - Per Site			\$60.00	.....	_____
(other than a proposed subdivision)					
Site Evaluation in Lieu of Groundwater Monitoring			\$60.00	.....	_____
(clears a site based on a determination that soil mottling not indicative of high groundwater)					

Subtotal..... \_\_\_\_\_

Priority Review: Enter same amount as subtotal..... \_\_\_\_\_

Prior approval from a section chief is required for a priority review.  
If approval is granted, the priority will be reviewed within 5 days of receipt.

Enter TOTAL here and on bottom of FRONT PAGE \$ \_\_\_\_\_

Note: Fees for aerobic or prepackaged treatment systems that may include trash tanks shall be calculated based on the rated capacity of the aerobic unit or prepackaged treatment system as compared to an equivalent septic tank size.

Note: Fees are pursuant to ch. Comm 2 and are subject to change annually; please contact any of the offices listed below for the most recent copy of this form.

Note: Comm 2 provides for a partial fee refund if a plan action has not been taken within the 15 days of receipt of all required information.

**7. Appointment, Scheduling Information, and Plan Submittal Checklists.** POWTS scheduling is not available. Plans will be assigned to a reviewer after receipt of plans.  
If you wish to receive confirmation of the assigned reviewer and estimated completion date please check the box in the upper right corner of the front page. Also note in the same location that you can designate a specific office for review. If you select a specific office your estimated completion date may be considerably greater than what would be possible in another office. Submittals received without a specific office indicated on the form may be assigned to offices other than the receiving office depending on reviewer availability. To obtain a submittal checklist call the material order unit at 608-266-1818 or one of the full service offices listed below

<p><b>Madison S&amp;BD</b> 201 W Washington Ave PO Box 7162 Madison WI 53707-7162 608-266-3151 Fax: 608-261-6699 TDD 608-264-8777 Email: madisonsch@commerce.state.wi.us</p>	<p><b>Hayward S&amp;BD</b> 15837 USH 63 Hayward WI 54843  715-634-4870 Fax: 715-634-5150 Email: haywardsch@commerce.state.wi.us</p>	<p><b>LaCrosse S&amp;BD.</b> 2226 Rose St LaCrosse WI 54603  608-785-9334 Fax: 608-785-9330 Email: lacrossesch@commerce.state.wi.us</p>	<p><b>Shawano S&amp;BD</b> 1340 E Green Bay Shawano WI 54166  715-524-3626 Fax: 715-524-3633 Email: shawanosch@commerce.state.wi.us</p>	<p><b>Green Bay S&amp;BD</b> 2331 San Luis Place Green Bay, WI 54304  920-492-5601 FAX: 920-492-5604 Email: greenbaysch@commerce.state.wi.us</p>	<p><b>Waukesha S&amp;BD</b> 401 Pilot Court Waukesha WI 53188  414-548-8600 Fax: 414-548-8614 Email: waukeshasch@commerce.state.wi.us</p>
--	---	---	---	--	---

**A-83.22 (3) Plan review process.** All proposed POWTS installations require plan review prior to sanitary permit issuance. Projects subject to department review include all projects under Table 83.22-1, and many of the projects under Table 83.22-2. Designated agents may review projects included in Table 83.22-2.

## County Plan Review Agents

February 07, 2000

County	Prefabricated Holding Tank 1 & 2 Family A / NA	Prefabricated Holding Tank Public Use Limited GPD	Conventional ST / SAS Public Use Limited GPD	Off Lot Systems HT or Conv. GPD / A / NA	Common Ownership Systems A / NA	Initial Approval Date	Next Scheduled Audit Date	Renewal Date
Brown	A <sup>1</sup>	A <sup>1</sup>	A	A	NA	10/31/94	1996	
Calumet	A <sup>1</sup>	3000 <sup>1</sup>	3000	3000	NA	8/26/94	1996	
Chippewa	A	3000	NA	NA	NA	2/21/97	1997	
Clark	A <sup>1</sup>	3000 <sup>1</sup>	NA	NA	NA	11/22/95	1996	
Eau Claire	A	A	A	A	NA	3/15/95	1998	
Fon du Lac	A	3000	3000	3000	NA	5/5/94	1997	
Green Lake	A	3000	3000	3000	NA	5/5/94	1996	
Langlade	A	3000	NA	3000	NA	4/8/94	1996	
Marathon	A <sup>1</sup>	NA	NA	NA	NA	9/16/98	1998	
Marinette	A <sup>1</sup>	A <sup>1</sup>	3000	3000	A	2/07/00	2001	
Monroe	A	3000	NA	NA	NA	10/31/94	1996	
Outagamie	A <sup>1</sup>	A <sup>1</sup>	NA	NA	NA	5/9/97	1997	
Polk	A	NA	NA	NA	NA	4/15/94	1997	
Trempealeau	A	A	NA	NA	NA	5/23/96	1997	
Waukesha	A	A	A	NA	NA	8/26/95	1996	
Waushara	A	3000	3000	3000	NA	3/25/94	1996	

A = Approved for Review

NA = No Approval

\* = Other Limitations See Approval Letter

Footnotes: 1. Approval for precast and site-constructed holding tanks.

Note: GPD limits are for ≤ the amount indicated.

Commerce Plan Review Offices		
Hayward Office 10541 N Ranch Rd Hayward WI 54843 (715) 634-4870	LaCrosse Office 4003 N Kinney Coulee Rd LaCrosse WI 54603 (608) 785-9334	Madison Office 201 W. Washington Ave PO Box 7162 Madison WI 53707-7162 (608) 266-3151
Shawano Office 1340 Green Bay Street Suite 300 Shawano WI 54166 (715) 524-3626	Green Bay Office 2331 San Luis Place Green Bay WI 54304 (920) 492-5601	Waukesha Office 141 NW Barstow St Waukesha WI 53186 (262) 548-8600

**A-83.25 (2) ISSUANCE OF BUILDING PERMITS.** A building permit is defined in s. Comm 81.01 (43), Wis. Adm. Code, as any written permission from a municipality that allows construction to commence on a structure. In effect, this means that land use and zoning permits, as well as other similar permits that constitute permission to construct are considered building permits.

Prior to building permit issuance, the issuing agent has a statutory responsibility, under s. 145.195, Wis. Stats., to consider whether or not the proposed structure requires connection to a private onsite wastewater treatment system (POWTS), or if the construction will interfere with the operation of an existing POWTS.

**Section 145.195, 1999 Stats. Building on unsewered property. (1)** No county, city, town or village may issue a building permit for construction of any structure requiring connection to a private domestic sewage treatment and disposal system unless a system satisfying all applicable regulations already exists to serve the proposed structure or all permits necessary to install such a system have been obtained.

**(2)** Before issuing a building permit for construction on any structure on property not served by a municipal sewage treatment plant, the county, city, town or village shall determine that the proposed construction does not interfere with a functioning private domestic sewage treatment and disposal system. The county, city, town or village may require building permit applicants to submit a detailed plan of the owner's existing private domestic sewage treatment and disposal system.

**A-83.25 (2) (e) Setbacks.** Horizontal setbacks from encumbrance for new POWTS installations are in conformance with Table Comm 83.43 -1 or the rules in effect at the time the system was installed, whichever is less. For setback distances associated with previous administrative codes refer to the previous code issue or the following table.

Code Comparison - POWTS Code Setback Encumbrances (ft)																	
Effective Date	Vertical Separation SAS				Horizontal Separation Soil Absorption System (SAS)							Horizontal Separation Treatment Tank <sup>a</sup>					
	Ground-water	Bedrock	Well	Lake <sup>b</sup>	Cistern	Building	Lot Line	Swimming Pool	Water Service	Public W Main	Well	Lake <sup>c</sup>	Cistern	Building	Lot Line	Swimming Pool	Water Service
6/21/87																	
3/1/97	3/6 <sup>k</sup>	3/6 <sup>k</sup>	50	50	25	25/15/10 <sup>h</sup>	5	15	10	25	25	10	5	2	5	10	
3/1/94	3/6 <sup>k</sup>	3/6 <sup>k</sup>	50	50	25	25/15/10 <sup>h</sup>	5	15	10	25	25	10	5	2	5	10	
3/1/92	3/6 <sup>k</sup>	3/6 <sup>k</sup>	50	50	25	25/15/10 <sup>h</sup>	5	15	10	25	25	10	5	2	5	10	
7/1/91	3/6 <sup>k</sup>	3/6 <sup>k</sup>	50	50	25	25/15/10 <sup>h</sup>	5	15	10	25	25	10	5	2	5	10	
10/1/85	3	3	50	50	25	25/15/10 <sup>h</sup>	5	15	10	25	25	10	5	2	15	10	
7/1/83	3	3	50	50	25	25/15/10 <sup>h</sup>	5	15	10	25	25	10	5	2	15	10	
1/1/81	3	3	50	50	25	25/15/10 <sup>h</sup>	5	15	10	25	25	10	5	2	15	10	
6/21/80	3	3	50	50	25	25/15/10 <sup>h</sup>	5	15	10	25	25	10	5	2	15	10	
2/1/79	3	3	50	50	25	25/10 <sup>h</sup>	5	25/15 <sup>h</sup>	10	25	25	10	5	2	25	10	
8/1/77	3 <sup>e</sup>	3 <sup>e</sup>	50	50	25	25/10 <sup>h</sup>	5	25/15 <sup>h</sup>	10	25	25	10	5	2	25	?	
8/1/76	3 <sup>e</sup>	3 <sup>e</sup>	50	50	25	25/10 <sup>h</sup>	5	25/15 <sup>h</sup>	10	25	25	10	5	2	25	?	
12/1/72	3	3	50	50	25	25	5	50	25	25	25	10	5	2	25	?	
11/1/71	3	3	50	50	25	25	5	50	25	25	25	10	5	2	25	?	
12/1/69	3	3	50	50	25	25	5	50	25	25	25	10	5	2	25	?	
3/1/63		0 <sup>e</sup>	50	25	25	25 <sup>g</sup>	5				25	10		2			
5/1/62		0 <sup>e</sup>	50	25	25	25 <sup>g</sup>	5				25	10		2			
3/1/57		0 <sup>e</sup>	50	25	25	25 <sup>g</sup>	5				25	10		2			
9/1/54		0 <sup>e</sup>	50	25	50	50 <sup>g</sup>	5				25	10		2			
1948			50	25	50	50 <sup>g</sup>					25	10		2			
1941			150'		50	50 <sup>g</sup>					25	10		2			
1937			150'		50	50 <sup>g</sup>					25	10		2			
1932			150'		50	50 <sup>g</sup>					25	10		2			
1925			150'		50	50 <sup>g</sup>					25	10		2			
1917			150'		50	50 <sup>g</sup>					25	10		2			
1916			150'		50	50 <sup>g</sup>					25	10		2			
1914			150'		50	50 <sup>g</sup>					25	10	10	2			

Footnotes:

- a. Includes water-tight cesspools, sewage tanks, septic tanks, dosing chambers.
- b. Lake category includes lakes, streams or other watercourses.
- c. Lake category includes lakes, streams, rivers, ponds, flowages and reservoirs.
- d. The code required 5 feet of soil over GW or BR. It is assumed that a 3 foot separation was maintained.
- e. Seepage pits shall not extend into creviced rock formations.
- f. May be reduced to 50 feet if well is drilled and cased to 100 ft.
- g. Means a dwelling.
- h. Refers to habitable or occupied bldg with below grade foundation/habitable bldg on slab/uninhabited bldg on slab.
- i. Refers to habitable buildings/uninhabited buildings.
- j. Refers to below ground/above ground swimming pools.
- k. Refers to normal soil/very coarse textured soil.



**A-83.43 (6) COMMERCIAL FACILITIES.** Table A-83.43-1 may be used to estimate wastewater flows from a commercial building.

<b>Table A-83.43-1 Public Facility Wastewater Flows</b>		
<b>Source</b>	<b>Unit</b>	<b>Estimated Wastewater Flow (gpd)</b>
Apartment or Condominium	Bedroom	100
Assembly hall (no kitchen)	Person (10 sq. ft./person)	1.3
Bar or cocktail lounge (no meals served)	Patron (10 sq. ft./patron)	4
Bar or cocktail lounge* (w/meals – all paper service)	Patron (10 sq. ft./patron)	8
Beauty salon	Station	90
Bowling alley	Bowling lane	80
Bowling alley (with bar)	Bowling lane	150
Camp, day and night	Person	25
Camp, day use only (no meals served)	Person	10
Campground or Camping Resort	Space, with sewer connection and/or service building	30
Campground sanitary dump station	Camping unit or RV served	25
Catch basin	Basin	65
Church (no kitchen)	Person	2
Church* (with kitchen)	Person	5
Dance hall	Person (10 sq. ft./person)	2
Day care facility (no meals prepared)	Child	12
Day care facility* (with meal preparation)	Child	16
Dining hall* (kitchen waste only without dishwasher and/or food waste grinder)	Meal served	2
Dining hall* (toilet and kitchen waste without dishwasher and/or food waste grinder)	Meal served	5
Dining hall* (toilet and kitchen waste with dishwasher and/or food waste grinder)	Meal served	7
Drive-in restaurant* (all paper service with inside seating)	Patron seating space	10
Drive-in restaurant* (all paper service without inside seating)	Vehicle space	10
Drive-in theater	Vehicle space	3
Employees (total all shifts)	Employee	13
Floor drain (not discharging to catch basin)	Drain	25
Gas station / convenience store	Patron	3

Table A-83.43-1 Public Facility Wastewater Flows (continued)		
Source	Unit	Estimated Wastewater Flow (gpd)
Gas station (with service bay)		
Patron	Patron	3
Service bay	Service bay	50
Hospital*	Bed space	135
Hotel, motel or tourist rooming house	Room	65
Medical office building		
Doctors, nurses, medical staff	Person	50
Office personnel	Person	13
Patients	Person	6.5
Migrant labor camp (central bathhouse)	Employee	20
Mobile Home (Manufactured home) (served by its own POWTS)	Bedroom	100
Mobile home park	Mobile home site	200
Nursing, Rest Home, Community Based Residential Facility	Bed space	65
Outdoor sport facilities (toilet waste only)	Patron	3.5
Parks (toilets waste only)	Patron (75 patrons/acre)	3.5
Parks (toilets and showers)	Patron (75 patrons/acre)	6.5
Public shower facility	Shower taken	10
Restaurant*, 24-hr. (dishwasher and/or food waste grinder only)	Patron seating space	4
Restaurant*, 24-hr. (kitchen waste only without dish washer and/or food waste grinder)	Patron seating space	12
Restaurant, 24-hr. (toilet waste)	Patron seating space	28
Restaurant*, 24-hr. (toilet and kitchen waste without dish washer and/or food waste grinder)	Patron seating space	40
Restaurant*, 24-hr. (toilet and kitchen waste with dish washer and/or food waste grinder)	Patron seating space	44
Restaurant* (dishwasher and/or food waste grinder only)	Patron seating space	2
Restaurant* (kitchen waste only without dishwasher and/or food waste grinder)	Patron seating space	6
Restaurant (toilet waste)	Patron seating space	14
Restaurant* (toilet and kitchen waste without dishwasher and/or food waste grinder)	Patron seating space	20
Restaurant* (toilet and kitchen waste with dishwasher and/or food waste grinder)	Patron seating space	22
Retail store	Patron (70% of total retail area ÷ 30 sq. ft. per patron)	1
School* (with meals and showers)	Classroom (25 students/classroom)	500
School* (with meals or showers)	Classroom (25 students/classroom)	400

Source	Unit	Estimated Wastewater Flow (gpd)
School (without meals and showers)	Classroom (25 students/ classroom)	300
Self-service laundry (toilet waste only)	Clothes washer	33
Self-service laundry (with only residential clothes wash ers)	Clothes washer	200
Swimming pool bathhouse	Patron	6.5

\* = May be high strength waste

**A-83.43 (6) (a).** Actual meter readings may be used to calculate the combined estimated design wastewater flow from a dwelling. To calculate the estimated design wastewater flow use the following formula and compare the answer to the peak metered flow. Choose the larger of the two estimated design flows.

$$(\text{total meter flow}/\text{number of readings})(1.5) = \text{estimated design wastewater flow}$$

The frequency of meter readings should be daily for commercial.

**A-83.43 (6) (b)** A detailed per capita and per function flow may be established for commercial facilities. The per function flow ratings shall be substantiated by manufacturers data of the per function flow and detailed use data from the facility in question or a similar facility under similar conditions of use. Estimated design wastewater flow shall be at least 1.5 times the total estimated daily flow calculated from the per capita and per function flow information

**A-83.43 (7) ESTIMATING CONTAMINANT LOADS**

Pathogenic contaminant load may be estimated based on data collected by a reputable testing or research facility.

**Typical Data on the Unit Loading Factors and Expected Wastewater Contaminant Loads from Individual Residences**

Contaminant	Unit Loading Factor lb/capita per day	Value		
		Unit	Range	Typical
BOD <sub>5</sub>	0.180	mg/L	216-540	392
SS	0.200	mg/L	240-600	436
NH <sub>3</sub> as N	0.007	mg/L	7-20	14
Org. N as N	0.020	mg/L	24-60	43
TKN as N	0.027	mg/L	31-80	57
Org. P as P	0.003	mg/L	4-10	7
Inorg. P as P	0.006	mg/L	6-17	12
Grease		mg/L	45-100	70
Total Coliform		cfu/100mL	10 <sup>7</sup> -10 <sup>10</sup>	10 <sup>8</sup>

**A-83.43 (8) (g) Anchoring system components.**

The anchoring of components to counter buoyant forces due to saturated soil conditions can be determined using the following formula:

$$\text{Weight of the component plus the weight of the anchor} = 1.5 \text{ times (volume of water the component displaces) times [the weight of water (62.4 pounds/cubic foot at 39°F)]}$$

A-83.44 ORIENTATION (6)

Orientation of above grade dispersal structures is on the contour except that a 1% cross slope is acceptable along the length as shown below.

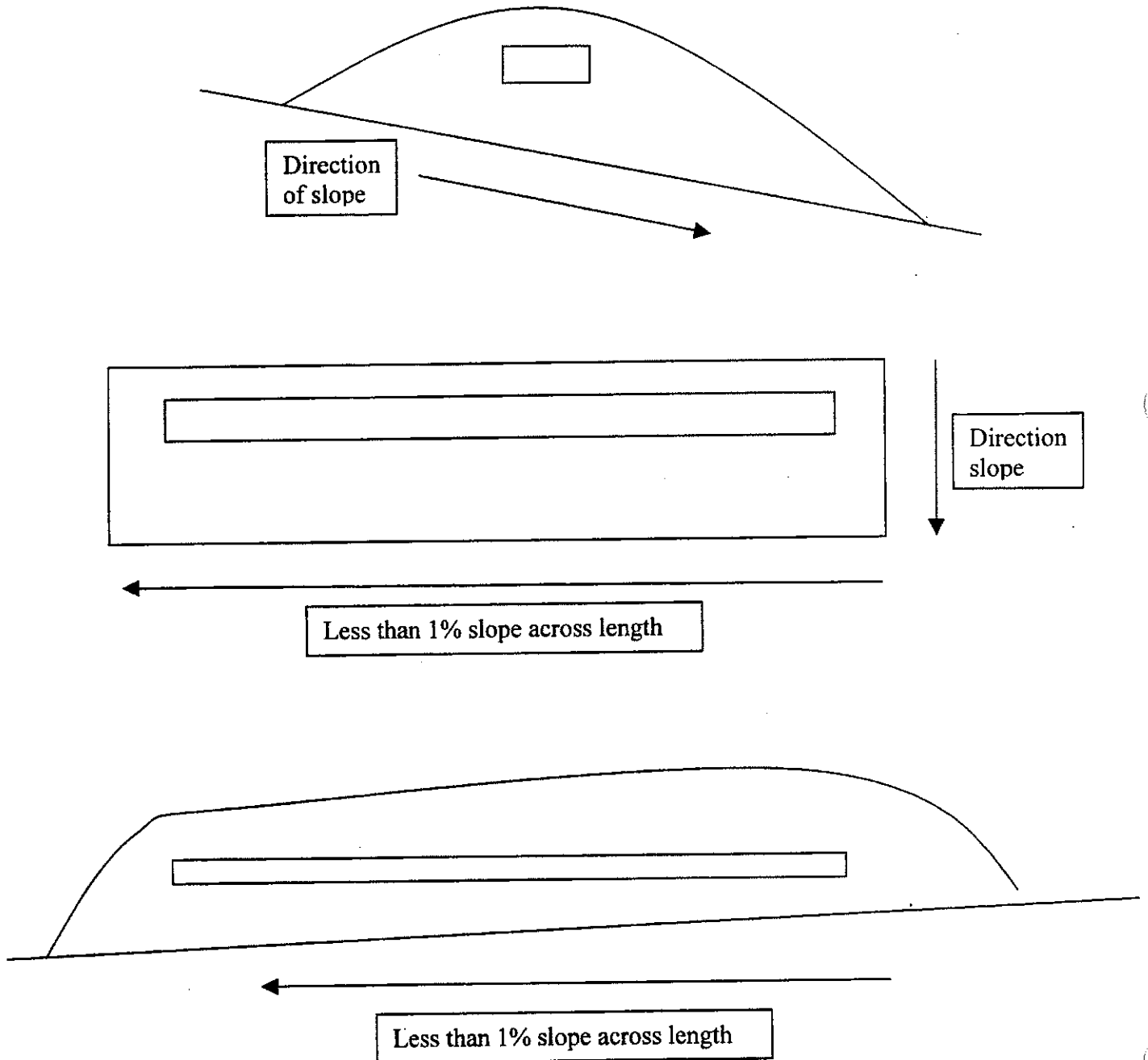

## Chapter Comm 84

### PLUMBING PRODUCTS

Comm 84.01 Scope.  
 Comm 84.02 Penalties.  
 Comm 84.03 Definitions.  
 Comm 84.10 Department approval.  
 Comm 84.11 Device listing.  
 Comm 84.12 Identification.  
 Comm 84.13 Penetrations of fire-resistive assemblies.

Comm 84.14 Chemical or biochemical treatments for private sewage systems.  
 Comm 84.15 Health care plumbing appliances.  
 Comm 84.20 Plumbing fixtures, appliances and equipment.  
 Comm 84.25 POWTS holding components or treatment components.  
 Comm 84.30 Plumbing materials.  
 Comm 84.40 Joints and connections.  
 Comm 84.50 Alternate approvals and experimental approvals.

**Note:** Chapter ILHR 84 as it existed on May 31, 1988 was repealed and a new chapter ILHR 84 was created effective June 1, 1988. Chapter ILHR 84 was renumbered Comm 84 under s. 13.93 (2m) (b) 1., Stats., and corrections made under s. 13.93 (2m) (b) 7., Stats., Register, February, 1997, No. 494.

**Comm 84.01 Scope.** The provisions of this chapter govern the quality and installation of materials, fixtures, appliances, appurtenances, and equipment relating to plumbing.

**History:** Cr. Register, May, 1988, No. 389, eff. 6-1-88.

**Comm 84.02 Penalties.** Penalties for violations of this chapter shall be assessed in accordance with s. 145.12, Stats.

**History:** Cr. Register, May, 1988, No. 389, eff. 6-1-88; correction made under s. 13.93 (2m) (b) 7., Stats., Register, July, 2000, No. 535.

**Comm 84.03 Definitions.** In this chapter:

(1) "Health care plumbing appliance" means a plumbing appliance, the function of which is unique to health care activities.

(2) "Laboratory plumbing appliance" means a plumbing appliance, the function of which is unique to scientific experimentation or research activities.

(3) "Prefabricated plumbing" means concealed drain piping, vent piping or water supply piping or a combination of these types of piping, contained in a modular building component, which will not be visible for inspection when delivered to the final site of installation.

**History:** Cr. Register, May, 1988, No. 389, eff. 6-1-88.

**Comm 84.10 Department approval.** No fixture, appliance, appurtenance, material, device or product may be sold for use in a plumbing system or may be installed in a plumbing system, unless it is of a type conforming to the standards or specifications of chs. Comm 82 and 83 and this chapter and ch. 145, Stats.

(1) **ALTERNATE OR EXPERIMENTAL PRODUCT APPROVAL.** If it is alleged that the approval of a fixture, appliance, appurtenance, material, device or product under this section would result in an adverse health effect or potentially adverse health effect on the waters of the state, the department may require an alternate or experimental product approval under s. Comm 84.50.

(2) **PRODUCT REVIEW AND APPROVAL.** (a) 1. Each type of plumbing product which falls into one of the categories specified in Table 84.10 shall be approved by the department in accordance with this subsection before the product may be sold for use in a plumbing system or installed in a plumbing system.

2. Specifications and plans or drawings for each type of product shall be submitted to the department for review. The submittal shall be accompanied by sufficient data and information to determine if the product and its performance comply with the provisions of chs. Comm 82, 83 and this chapter and ch. 145, Stats.

(b) The department may require that a submitter of a product for review have the product tested and its performance certified by an approved testing laboratory.

(c) If, upon review, the department determines that a product conforms to the provisions of chs. Comm 82, 83 and this chapter and ch. 145, Stats., the department shall issue an approval in writ-

ing. The department may impose specific conditions in granting an approval. Violations of the conditions under which an approval is granted shall constitute a violation of this chapter.

(d) If, upon review, the department determines that a product does not conform to provisions of chs. Comm 82, 83 and this chapter and ch. 145, Stats., the request for approval shall be denied in writing.

(e) The department shall review and make a determination on an application for a product approval within 40 business days of receipt of all fees, plans, drawings, specifications and other information required to complete the review.

(f) If an approved plumbing product is modified or additional assertions of function or performance are made, the approval shall be considered null and void, unless the change is submitted to the department for review and the approval is reaffirmed.

(g) Approvals for plumbing products issued by the department prior to November 1, 1985, shall expire 30 months after the effective date of this section.

(h) Approvals for plumbing products issued by the department after November 1, 1985, shall expire at the end of the 60th month after the date of approval issuance.

**Table 84.10**  
**SUBMITTALS TO DEPARTMENT**

Product Categories
1. Chemical or biochemical treatments for POWTS
2. Health care plumbing appliances
3. Physical restoration processes for POWTS
4. Prefabricated holding or treatment components for POWTS
5. Prefabricated plumbing
6. Water treatment devices or bottled water vending machines not listed by a nationally recognized listing agency as complying with NSF Standard 44
7. Wastewater treatment devices used to meet the requirements in s. Comm 82.70
8. Exterior grease interceptors
9. Exterior lift tanks

(3) **VOLUNTARY POWTS COMPONENT REVIEW.** (a) The department may issue an approval, upon request and review, for specific methods or technologies that are proposed to be utilized as POWTS holding, treatment or dispersal components which conform to the standards or specifications referenced in chs. Comm 81, 82, 83 and this chapter, but do not require approval under sub. (2) or s. Comm 84.50.

(b) Each request for approval shall be made on a form provided by the department.

**Note:** See appendix for a reprint of the form and addresses of the department where the form may be obtained.

(c) The submittal shall be accompanied by sufficient data and information to determine if the method or technology complies with the provisions of chs. Comm 81, 82 and 83, and this chapter.

The submittal shall include, but not be limited to, all of the following:

1. Plans and specifications.
2. Theory of operation.
3. Testing protocol.
4. Testing data.
5. Limits of reliable operation.
6. Installation requirements and procedures.
7. Inspection checklist and worksheet.
8. Inspection requirements and procedures.
9. Operation and maintenance requirements.
10. Operation and maintenance schedule.
11. Operation and maintenance checklist and worksheet.

(d) 1. The department shall review a submittal under this subsection with input from a technical advisory committee.

2. The members on the technical advisory committee under subd. 1. shall be appointed by the department for staggered 3-year terms and shall include representatives of at least the following groups or organizations:

- a. The department of natural resources.
- b. Local governmental unit.
- c. POWTS designer.
- d. Academic or scientific community.
- e. Plumber.
- f. Environmental group.
- g. POWTS component manufacturer.

(e) 1. After review by the technical advisory committee under par. (d) but prior to issuing an approval under par. (f), the department shall seek public comments on a submittal under this subsection.

2. a. The department shall place the notice requesting public comment under subd. 1. in the official state newspaper.

**Note:** The official state newspaper at the time this rule goes into effect, July 1, 2000, is the Wisconsin State Journal.

b. The department shall include a time limit for public comment in each notice.

3. If the department receives a significant amount of public comment under subd. 2., the department may elect to recognize the specific method or technology through the rule-making process under ch. 227, Stats., and to cite the recognition in s. Comm 83.61.

(f) 1. If, upon review, the department determines that the method or technology conforms to the provisions of chs. Comm 81, 82 and 83 and this chapter, the department shall issue an approval in writing.

2. The department may impose specific conditions in granting an approval, including a provision to provide training to POWTS installers and POWTS inspectors.

3. Violations of the conditions under which an approval is granted shall constitute a violation of this chapter.

(g) If, upon review, the department determines that the method or technology does not conform to the provisions of chs. Comm 81, 82 and 83 and this chapter, the request for approval shall be denied in writing.

(h) The department shall review and make a determination on an application for a method or technology approval within 3 months of receipt of all fees, plans, drawings, specifications and other information required to complete the review, unless the department elects to review the method or technology as part of the rule-making process under ch. 227, Stats.

(i) If an approved method or technology is modified or additional assertions of function or performance are made, the approval shall be considered null and void, unless the change is submitted to the department for review and the approval is reaffirmed.

**(4) REVOCATION.** The department may revoke any approval issued under this section for any false statements or misrepresentation of facts on which the approval was based, or as a result of the product's failure, or if data indicate a health hazard or threat to the waters of the state.

**(5) LIMITATIONS.** An approval of a plumbing product by the department may not be construed as an assumption of any responsibility for defects in design, construction or performance of any product nor for any damages that may result. All products shall be installed in accordance with the manufacturer's printed instructions and as specified in chs. Comm 82 to 84. If there is a conflict between the manufacturer's printed instructions and requirements of chs. Comm 82 to 84, the requirements of chs. Comm 82 to 84 shall take precedence.

**(6) FEES.** Fees for product approval review shall be submitted in accordance with s. Comm 2.66.

**History:** Cr. Register, May, 1988, No. 389, eff. 6-1-88; correction made in (6) under s. 13.93 (2m) (b) 7., Stats., Register, February, 1994, No. 458; emerg. am. Table 84.10, (2) (a) (intro.), r. (2) (a) 2., eff. 5-12-94; renum. (2) (a) (intro.), 1. and 2. to be 1., 2. and 3., r. (2) (a) 3., am. Table 84.10, Register, October, 1994, No. 466, eff. 11-1-94; am. Table 84.10 and r. and recr. (3), Register, April, 2000, No. 532, eff. 7-1-00; r. (2) (a) 2., renum. (2) (a) (intro.) and 1. to be (2) (a) 1. and 2. and am. (2) (a) 2., am. (5), (6) and Table 84.10, Register, July, 2000, No. 535, eff. 9-1-00; am. (4) and (5), Register, December, 2000, No. 540, eff. 1-1-01; CR 02-002: am. Table Register April 2003 No. 568, eff. 5-1-03.

**Comm 84.11 Device listing.** Cross connection control devices and water treatment devices complying with the referenced standard in Table 84.11 shall be listed by a nationally recognized listing agency acceptable to the department.

**Note:** See appendix for acceptable listing agencies.

Table 84.11  
DEVICE LISTINGS

Device	Referenced Standard
Atmospheric Type Vacuum Breakers	CAN/CSA B64.1.1
Back Siphonage Vacuum Breakers	ASSE 1056
Backflow Preventers for Carbonated Beverage Machine	ASSE 1022
Backflow Preventers with Intermediate Atmospheric Vent	ASSE 1012
Chemical Dispensing Systems	ASSE 1055
Double Check Backflow Prevention Assemblies	ASSE 1015
Double Check Detector Assembly Preventers	ASSE 1048
Double Check Valve Type Backflow Preventers	CAN/CSA B64.5
Dual Check Valve Type with Atmospheric Port Backflow Preventers	CAN/CSA B64.3
Hand Held Showers	ASSE 1014
Hose Connection Backflow Preventers	ASSE 1052
Hose Connection Type Vacuum Breakers	CAN/CSA B64.2
Hose Connection Vacuum Breakers	ASSE 1011
Laboratory Faucet Backflow Preventers	ASSE 1035
Laboratory Faucet Type Vacuum Breakers	CAN/CSA B64.7
Pipe Applied Atmospheric Type Vacuum Breakers	ASSE 1001
Pressure Type Vacuum Breakers	CAN/CSA B64.1.2
Pressure Vacuum Breakers	ASSE 1020
Pressurized Flushing Devices (Flushometers) for Plumbing Fixtures	ASSE 1037
Reduced Pressure Detector Assembly Backflow Preventers	ASSE 1047
Reduced Pressure Principle Backflow Preventers	ASSE 1013
Reduced Pressure Principle Type Backflow Preventers	CAN/CSA B64.4
Water Closet Flush Tank Ballcocks	ASSE 1002
Wall Hydrants, Freeze Resistant, Automatic Draining Type	ASSE 1019
Residential Cation Exchange Water Softeners	NSF 44

History: Cr. Register, July, 2000, No. 535, eff. 9-1-00; CR 02-002: am. Table Register April 2003 No. 568, eff. 5-1-03.

**Comm 84.12 Identification.** Each length of pipe and each pipe fitting, trap, fixture, material, device and product to be used in plumbing shall be marked as required by the applicable standard specified by reference in this chapter or as specified by rule in this chapter.

History: Cr. Register, May, 1988, No. 389, eff. 6-1-88; am. Register, April, 2000, No. 532, eff. 7-1-00; renum. from s. Comm 84.11, Register, July, 2000, No. 535, eff. 9-1-00.

**Comm 84.13 Penetrations of fire-resistive assemblies.** Penetrations of fire-resistive assemblies, such as walls and floor-ceiling systems, by plumbing systems or plumbing materials shall be protected in accordance with requirements of chs. Comm 61 to 65.

History: Cr. Register, May, 1988, No. 389, eff. 6-1-88; correction made under s. 13.93 (2m) (b) 7., Stats.; renum. from s. Comm 84.12, Register, July, 2000, No. 535, eff. 9-1-00; correction made under s. 13.93 (2m) (b) 7., Stats., Register June 2002 No. 558.

**Comm 84.14 Chemical or biochemical treatments for private sewage systems.** Chemical or biochemical treatments for private sewage systems shall function and perform in accordance with the assertions submitted to the department. Chemical or biochemical treatments for private sewage systems may not directly or indirectly adversely affect bacterial action in the systems, soil hydraulic conductivity in the absorption areas, or groundwater quality beneath the systems.

History: Cr. Register, May, 1988, No. 389, eff. 6-1-88; renum. from s. Comm 84.13, Register, July, 2000, No. 535, eff. 9-1-00.

**Comm 84.15 Health care plumbing appliances.** Health care plumbing appliances shall function and perform in accordance with the drain, vent, water supply and backflow protection requirements of ch. Comm 82.

History: Cr. Register, May, 1988, No. 389, eff. 6-1-88; renum. from s. Comm 84.14, Register, July, 2000, No. 535, eff. 9-1-00; CR 02-002: am. Register April 2003 No. 568, eff. 5-1-03.

**Comm 84.20 Plumbing fixtures, appliances and equipment. (1) DESIGN AND CONSTRUCTION.** All plumbing fixtures, appliances and equipment shall be designed and constructed to:

- (a) Ensure durability, proper service and sanitation;
- (b) Be free from defects;
- (c) Be free from concealed fouling surfaces;
- (d) Not require undue efforts in cleaning and operating; and
- (e) Prevent nonpotable liquids, solids or gasses from being introduced into a potable water supply system through cross-connections.

**(2) MATERIALS.** (a) Plumbing fixtures shall have smooth surfaces that are impervious to water.

(b) All plumbing fixture fittings which are end-point devices, covered by the scope of NSF 61, section 9 and installed to supply water intended for human ingestion, shall conform to NSF 61, section 9.

Note: The scope of NSF 61, section 9 defines which devices are intended for use for human ingestion in response to the Federal clean drinking water act.

**(3) WATER CONSERVING FAUCETS, SPOUTS AND PLUMBING FIXTURES.** Water conserving faucets, spouts and plumbing fixtures which meet or exceed the water conservation requirements established in par. (b) shall be installed as specified in par. (a).

(a) 1. All lavatory faucets, shower heads, urinals, urinal flushing devices, water closets and water closet flushing devices shall conform to par. (b).

2. All faucets installed on kitchen sinks of dwelling units and living units shall conform to par. (b) 4.

(b) 1. General. Flow control or flow restricting devices shall be installed on the water inlet side or shall be an integral part of the faucet, spout or fixture. A flow controlling or restricting aerator shall be considered to be an integral part of a faucet or spout.

- 2. Lavatory faucet. a. The maximum discharge rate of lavatory faucets shall be 3 U.S. gallons per minute at an 80 psig flowing supply pressure.
- b. Lavatory faucets which are of the self-closing type shall allow a maximum of one U.S. gallon to flow through the faucet after the handle or actuator is released.
- 3. Shower heads. The maximum discharge rate of shower heads shall be 3 U.S. gallons per minute at an 80 psig flowing supply pressure.
- 4. Sink faucets. The maximum discharge rate of sink faucets shall be 3 U.S. gallons per minute at an 80 psig flowing supply pressure.
- 5. Urinals. Urinals shall function properly with a maximum of 1.5 U.S. gallons per flush per fixture use at static test pressures of 20 psig and 80 psig.
- 6. Urinal flushing devices. The flushing cycle for urinal flushing devices shall discharge a maximum of 1.5 U.S. gallons per flush per fixture use at static test pressures of 20 psig and 80 psig.
- 7. Water closets. Water closets shall function properly with a maximum of 4 U.S. gallons per flush over the range of static test pressures specified in Table 84.20.
- 8. Water closet flushing devices. The flushing cycle for water closet flushing devices shall discharge a maximum of 4 U.S. gallons over the range of static test pressures specified in Table 84.20.

Table 84.20

STATIC TEST PRESSURES FOR WATER CLOSETS AND WATER CLOSET FLUSHING DEVICES

Tank Type	Flushometer Type	
	Siphonic	Blow Out
20 to 80 psig	25 to 80 psig	35 to 80 psig

- (4) GENERAL REQUIREMENTS. (a) *Fixture outlets*. 1. The outlet passageway of a fixture shall be free from impairments and of sufficient size to insure proper discharge of the fixture contents under normal conditions.
- 2. The outlet connection of a fixture which directly connects to the drain system shall be an air and watertight joint.
- (b) *Installation of fixtures*. 1. Access for cleaning. Plumbing fixtures shall be so installed as to afford easy access for cleaning both the fixture and the area around it.
- 2. Securing wall mounted fixtures. Wall mounted fixtures shall be rigidly supported by a hanger which is attached to structural members so that the load is not transmitted to the fixture drain connection or any other part of the plumbing system. The hanger for a wall mounted water closet shall conform to ASME A112.6.1M.
- 3. Water supply protection. The water supply pipes and fittings within every plumbing fixture shall be so installed as to prevent backflow.
- 4. Design of overflow. A fixture which is provided with an overflow outlet shall be designed and installed so that standing water in the fixture cannot rise in the overflow when the fixture's stopper is closed, and so that no water remains in the overflow when the fixture is empty.
- 5. Connection of overflows. The overflow from any fixture shall discharge into the drain system on the inlet or fixture side of the trap.
- 6. Overflows in flush tanks. Flush tanks shall be provided with overflows discharging to the fixture served and shall be of sufficient size to prevent flooding the tank at the maximum rate at which the tanks are supplied with water.
- 7. Strainers. All plumbing fixtures other than water closets, clinic sinks, trap standard service sinks with flush rims, urinals, standpipes and waste sinks shall be provided with strainers, cross

bars or pop-up stoppers which restrict the clear opening of the waste outlet.

- 8. Flushometer valves. Flushometer valves shall be equipped with vacuum breakers which conform to ASSE 1001. Flushometer valves may not be used where the water pressure is insufficient to properly operate them. When the valve is operated, it shall complete the cycle of operation automatically, opening fully and closing positively under the water supply pressure. Each flushometer shall be provided with a means for regulating the flow through it.
- 9. Safing. a. The floor of all site-constructed shower stalls and shower rooms shall be protected with a safing material installed beneath the finished floor of the entire enclosure or room and upward along the sides to a minimum of 6 inches above the curb or maximum water level of the room or enclosure. The corners of the enclosure or room shall be safed to a height of 6 feet and at least 3 inches in each direction from the corners.
- b. All floor drains or other similar fixtures shall be installed with a safing material extending a minimum of 12 inches from the fixture.
- c. The safing material shall conform to s. Comm 84.30 (6).
- d. The safing material shall be properly drained.
- e. All installations directly over an unexcavated portion of a building are exempt from this subdivision.

Note: Chapters Comm 61 to 65 and 90 contain provisions for toilet rooms and sanitary facilities for public buildings and places of employment, including provisions concerning toilet facilities for people with disabilities, fixture compartments, number of fixtures for the different types of occupancies, and toilet room finishes.

- (5) PLUMBING FIXTURES AND PLUMBING APPLIANCES. (a) *Automatic clothes washers*. Residential type automatic clothes washers shall conform to ASSE 1007.
- (b) *Bathtubs*. 1. a. Enameled cast iron bathtubs shall conform to ASME A112.19.1M.
- b. Porcelain enameled formed steel bathtubs shall conform to ASME A112.19.4.
- c. Plastic bathtubs shall conform to ANSI Z124.1.
- 2. Bathtubs shall have waste outlets and overflows at least 1-1/2 inches in diameter. A closing device shall be provided on the waste outlet.
- 3. All whirlpool piping for bathtubs shall drain by gravity to the trap serving the bathtub.
- 4. All waterways of the whirlpool pump for a bathtub shall drain by gravity to the trap serving the bathtub.
- (c) *Bidets*. Vitreous china bidets shall conform to the material requirements in ASME A112.19.2M.
- 1. A bidet may not be located closer than 15 inches from its center to any side wall, partition, vanity or other obstruction, nor closer than 30 inches center to center from a water closet.
- 2. Bidets with submerged inlet fittings shall be protected by vacuum breakers which conform to ASSE 1001 or CAN/CSA B64.1.1.
- (d) *Chemical dispensing systems*. Chemical dispensing systems shall conform to ASSE 1055.
- (e) *Dishwashing machines*. 1. Residential type dishwashing machines shall conform to ASSE 1006.
- 2. Commercial type dishwashing machines shall conform to ASSE 1004.
- (f) *Drinking fountains*. 1. Drinking fountains and water coolers shall conform to ARI 1010 or ASME A112.19.2M.
- 2. Drinking fountains may not be installed in toilet rooms.
- 3. The water supply for drinking fountains shall be provided with an adjustable valve fitted with a loose key or an automatic self-closing valve permitting regulation of the rate of flow of water. The water supply issuing from the nozzle shall be of sufficient volume and height so that persons using the fountain need not come in direct contact with the nozzle or orifice.



4. A drinking fountain may not have a waste outlet less than 1-1/4 inches in diameter.

(g) *Floor drains.* 1. Floor drains shall be provided with removable strainers of sufficient strength to carry the anticipated loads.

2. The floor drain shall be so constructed that it can be cleaned, and the drain inlet shall be accessible at all times.

3. Floor drains shall be of a size to efficiently serve the intended purpose. The floor drain outlet shall not be less than 2 inches in diameter.

(h) *Food waste grinders.* 1. Residential type food waste grinders shall conform to ASSE 1008. Commercial type food waste grinders shall conform to ASSE 1009.

2. Food waste grinders shall be connected to a drain of sufficient size to serve the unit, but not less than 1 1/2 inches in diameter.

3. All food waste grinders shall be provided with an adequate supply of cold water at a sufficient flow rate to insure proper functioning of the unit.

(i) *Laundry trays.* Each compartment of a laundry tray shall be provided with a waste outlet not less than 1 1/2 inches in diameter.

(j) *Lavatories.* 1. a. Enameled cast iron lavatories shall conform to ASME A112.19.1M.

b. Vitreous china lavatories shall conform to ASME A112.19.2M.

c. Stainless steel lavatories shall conform to ASME A112.19.3.

d. Porcelain enameled formed steel lavatories shall conform to ASME A112.19.4.

e. Plastic lavatories shall conform to ANSI Z124.3.

2. Cultured marble vanity tops with an integral lavatory shall conform to ANSI Z124.3.

3. Lavatories shall have waste outlets not less than 1 1/4 inches in diameter.

(k) *POWTS design packages and POWTS components.* POWTS design packages and POWTS components shall function and perform in accordance with assertions submitted to and approved by the department under s. Comm 84.10.

(L) *Showers.* 1. Prefabricated plastic showers and shower compartments shall conform to ANSI Z124.2.

2. Except for combination bathtub-shower units, waste outlets serving showers shall be at least 2 inches in diameter and shall have removable strainers of sufficient strength for the anticipated loads.

3. Where a waste outlet serves more than one shower space or shower head, the waste outlet shall be at least 2 inches in diameter and the waste outlet shall be so located and the floor so pitched that waste water from one shower does not flow over the floor area serving another shower.

Note: Chapters Comm 61 to 65 specify slip-resistant requirements for shower rooms and compartments in public buildings and places of employment.

4. All shower compartments, regardless of shape, shall have a minimum finished interior of 900 square inches and shall be capable of encompassing a circle with a diameter of 30 inches. The minimum required area and dimension shall be measured in a horizontal plane 24 inches above the top of the threshold and may not extend beyond the centerline of the threshold. The minimum area and dimensions shall be maintained to a point 70 inches above the shower waste outlet with no protrusions other than the fixture valve or valves, showerheads, soap dishes, retractable seats and safety grab bars or rails.

Note: See Appendix for further explanatory materials.

(m) *Sinks.* 1. a. Enameled cast iron sinks shall conform to ASME A112.19.1M.

b. Vitreous china sinks shall conform to ASME A112.19.2M.

c. Stainless steel sinks shall conform to ASME A112.19.3.

d. Porcelain enameled formed steel sinks shall conform to ASME A112.19.4.

e. Plastic sinks shall conform to ANSI Z124.6.

2. Sinks shall be provided with waste outlets not less than 1 1/2 inches in diameter.

(n) *Urinals.* 1. a. Vitreous china urinals shall conform to ASME A112.19.2M and A112.19.6.

b. Plastic urinals shall conform to ANSI Z124.9 and ASME A112.19.6.

2. A urinal may not be located closer than 15 inches from its center to any side wall, partition, vanity or other obstruction, nor closer than 30 inches center to center, between urinals.

Note: See Appendix for further explanatory material.

3. Stall type urinals shall be set into the floor and the floor shall be pitched toward the fixture.

4. Automatic siphon urinal flush tanks may not be installed.

5. Pressurized flushing devices to serve urinals shall conform to ASSE 1037.

(o) *Water closets.* 1. a. Vitreous china water closets shall conform to ASME A112.19.2M and A112.19.6.

b. Plastic water closets shall conform to ANSI Z124.4.

2. Except as permitted in subd. 3., all water closets required to be provided in public buildings and places of employment shall be of an elongated bowl type, and provided with either:

a. Hinged, open-front seats without covers; or

b. Hinged, closed-front seats, without covers, which are encased with a continuous plastic sleeve capable of providing a clean surface for every user and for which a specific material approval under s. Comm 61.60 has been issued.

3. Water closets which are required to be provided in day care centers or individual living units or sleeping units of residential occupancies within the scope of chs. Comm 61 to 65 may be of a round-bowl type with a hinged, closed front seat with or without a cover.

4. A water closet may not be located closer than 15 inches from its center to any side wall, partition, vanity, or other obstruction, nor closer than 30 inches center to center, between water closets. There shall be at least 24 inches clearance in front of a water closet to any wall, fixture or door.

Note: See Appendix for further explanatory material.

5. No person may install or maintain pan, plunger, offset washout, washout, long hopper, frostproof and other types of water closets having invisible seals or unventilated spaces or walls not thoroughly cleansed at each flushing.

6. Each water closet shall be individually equipped with a flushing device. Pressurized flushing devices shall conform to ASSE 1037. All flushing devices shall be readily accessible for maintenance and repair. Ballcocks and fill valves shall be of the anti-siphon type and shall conform to ASSE 1002. The critical level mark on the ballcock and fill valve shall be located at least one inch above the full opening of the overflow pipe.

(p) *Water heaters.* 1. Listed equipment. All water heaters shall bear the label of a listing agency approved by the department. Listing agencies approved by the department shall include:

a. Underwriters Laboratories, Inc.;

b. American Gas Association;

c. American Society of Mechanical Engineers; and

d. ETL Testing Laboratories, Inc.

2. Design. a. All pressurized water heaters and pressurized hot water storage tanks, except those bearing the label of the American Society of Mechanical Engineers, shall be designed and constructed to withstand a minimum test pressure of 150% of the maximum allowable working pressure of the heater or tank.

b. All pressurized water heaters and pressurized hot water storage tanks shall be rated for a minimum working pressure of 125 psig.

c. A drain valve shall be installed at the lowest point of each water heater and hot water storage tank. Drain valves shall conform to ASSE 1005.

3. Safety devices. a. Relief valves shall be listed by the American Gas Association, Underwriters Laboratories, Inc. or American Society of Mechanical Engineers when the heat input to a water heater is less than or equal to 200,000 Btu per hour.

b. Relief valves shall be listed by the American Society of Mechanical Engineers when the heat input to a water heater exceeds 200,000 Btu per hour.

c. Pressure relief valves shall be set to open at either the maximum allowable working pressure rating of the water heater or storage tank or 150 psig, whichever is smaller.

d. Temperature and pressure relief valves shall be set to open at a maximum of 210° F and in accordance with subd. 3. c.

Note: See s. Comm 82.40 (5) (d) 1. concerning the sizing of temperature and pressure relief valves.

4. Hot water dispensers. Nonpressurized point-of-use water heaters shall conform to ASSE 1023.

(q) *Water meters.* A water meter which is used pursuant to s. Comm 83.54 (2) shall conform to AWWA C700, AWWA C701, AWWA C702, AWWA C704, AWWA C706, AWWA C707, AWWA C708, or AWWA C710.

(r) *Water treatment devices.* 1. Water softeners shall conform to NSF-44.

Note: See s. Comm 82.40 for limitations as to the types of water treatment devices which may discharge to a POWTS.

2. a. Except as provided in subd. 2. b., water treatment devices shall function and perform in accordance with the assertions submitted to the department under s. Comm 84.10, relating to rendering inactive or removing contaminants.

b. A water treatment device which injects a water treatment compound into a water supply system shall maintain the compound concentration in the system over the working flow rate range and pressure range of the device.

3. Except as specified in subd. 4., water treatment compounds introduced into the water supply system by a water treatment device shall be listed as an acceptable drinking water additive by a listing agency approved by the department. Listing agencies approved by the department shall include:

- a. United States environmental protection agency;
- b. United States food and drug administration; and
- c. National sanitation foundation.

4. A water supply system shall be protected from backflow when unlisted water treatment compounds, which may affect the potability of the water, are introduced into the system. The department shall determine the method of backflow protection. Water supply outlets for human use or consumption may not be installed downstream of the introduction of an unlisted water treatment compound.

5. Water treatment devices designed for contaminated water supplies shall be labeled to identify the following information:

- a. The name of the manufacturer of the device;
- b. The device's trade name; and
- c. The device's model number.

(s) *Other plumbing fixtures, appliances and equipment.* Plumbing fixtures, appliances and equipment not specifically covered in this subsection shall conform to the applicable performance standards of this chapter and chs. Comm 82 and 83.

(6) **FAUCETS, SPOUTS AND FIXTURE SUPPLY CONNECTORS.** (a) Except for circular and semi-circular wash fountains, all faucets and showerheads shall conform to ASME A112.18.1M or CAN/CSA B125.

(b) Circular and semi-circular wash fountains shall conform to the working pressure, burst pressure, discharge rate and product

marking requirements of ASME A112.18.1M or CAN/CSA B125.

(c) 1. Except as provided in subd. 2., all fixture supply connectors shall be designed and constructed to withstand a minimum pressure of 100 psig at 180°F.

2. All fixture supply connectors installed on a cold water supply serving fixtures, appliances and devices that provide  $\leq 1.0$  gpm at each outlet shall be designed and constructed to withstand a minimum pressure of 100 psig at 73.4°F.

(d) Flexible hose and spray assemblies for residential sinks shall conform to ASSE 1025.

(e) Hand-held showers shall conform to ASSE 1014.

History: Cr. Register, May, 1988, No. 389, eff. 6-1-88; r. (5) (m) 2. to 5., cr. (5) (m) 2. and 3., renum. (5) (m) 7. and 8. to be (5) (m) 4. and 5., Register, March, 1991, No. 423, eff. 4-1-91; am. (5) (l) 1. and (m) 1. a., Register, April, 1992, No. 436, eff. 5-1-92; renum. (5) (o) and (p) to be (5) (p) and (q), cr. (5) (l) 5., (n) 1. d. and (o), am. (5) (m) 6., (n) 1. b. and c., Register, February, 1994, No. 458, eff. 3-1-94; emerg. r. (3) (a) 3., eff. 5-12-94; r. (3) (a) 3., Register, October, 1994, No. 466, eff. 11-1-94; correction in (5) (m) 3. made under s. 13.93 (2m) (b) 7., Stats; renum. (5) (j) to (q) to be (5) (k) to (r) and cr. (5) (j), Register, April, 2000, No. 532, eff. 7-1-00; renum. (2) to be (2) (a) and am., (5) (d) to (r) to be (5) (e) to (s) and am. (5) (f), (j) 1. a. to d., (m) 1. and 2., (n) 1. and 2., (o) 1. a., (6) (a) and (b), (r) 1., (5) (L) 2. and renum. 3. to 5. to be 2. to 4.; am. (4) (b) 2., cr. (2) (b), (5) (d), (m) 1. e., (n) 1. b.; r. and recr. (4) (b) 9., Register, December, 2000, No. 540, eff. 1-1-01; CR 01-139; am. (5) (o) 2. b. and 3. Register June 2002 No. 558, eff. 7-1-02; correction in (5) (q) made under s. 13.93 (2m) (b) 7., Stats., Register June 2002 No. 558; CR 02-002; am. (5) (n) 2., r. and recr. (6) (c) Register April 2003 No. 568, eff. 5-1-03; CR 02-129; r. (5) (h) 3., renum. (5) (h) 4. to be 3. Register January 2004 No. 577, eff. 2-1-04.

**Comm 84.25 POWTS holding components or treatment components.** (1) **GENERAL.** All POWTS holding components or treatment components shall conform to the requirements of this section.

(2) **WATER TIGHTNESS.** (a) *General.* Tank assemblies, including fittings and access openings, shall be manufactured to be water tight as required under this subsection.

(b) *Concrete tanks.* 1. Where concrete tanks are required to have covers, the tanks shall meet one of the following requirements:

a. Withstand a vacuum of at least 2 inches of mercury for 60 minutes, without loss of pressure.

b. Hold water for one hour, without leakage after the tank has been filled with water to the top of the cover and let stand for 24 hours, then refilled to the top of the cover.

2. Concrete tanks that are not required to have a cover shall hold water for one hour, without leakage after the tank has been filled with water and let stand for 24 hours, then refilled to the highest liquid level required to be held in the tank.

(c) *Steel tanks.* 1. Steel tanks that are required to have a cover shall be capable of withstanding one of the following requirements:

a. An internal air pressure of at least 5 psig for 15 minutes, without loss of pressure.

b. An internal water pressure of at least 5 psig for 60 minutes, without loss of pressure.

2. Steel tanks that are not required to have a cover shall be capable of holding water after being filled to their inlet or outlet, whichever is higher, for 24 hours without loss of water.

(d) *Tanks constructed of materials other than concrete or steel.* 1. Tanks constructed of materials other than concrete or steel that are required to have a cover shall be capable of withstanding one of the following requirements:

a. A vacuum of at least 2 inches of mercury for 60 minutes, without loss of pressure.

b. An internal air pressure of at least 5 psig for 15 minutes, without loss of pressure.

c. An internal water pressure of at least 5 psig for 60 minutes, without loss of pressure.

2. Tanks constructed of materials other than concrete or steel that are not required to have a cover shall be capable of holding

water after being filled to their inlet or outlet, whichever is higher, for one hour without loss of water.

**(3) STRENGTH.** Tank assemblies, including fittings and access openings, shall be capable of withstanding loads and pressures that the tanks are intended to encounter and remain watertight.

**(4) PROTECTION FROM ELEMENTS.** (a) *Concrete tanks.* 1. The interior of a concrete tank assembly, including fittings and access openings, shall have a protective coating or be constructed of material, above the lowest liquid level expected in the tank, that will inhibit the deterioration of the concrete due to internal environmental effects.

2. Under subd. 1., concrete with a water cement ratio not exceeding 0.45 shall be considered resistant to deterioration due to internal environmental effects.

(b) *Steel tanks.* 1. Steel tank assemblies, including fittings and access openings, shall have a protective coating that will inhibit the deterioration of the steel due to internal and external environmental effects.

2. Steel tank assemblies, including fittings and access openings, installed underground shall be provided with cathodic protection in accordance with UL Standard 1746 or STI-P<sub>3</sub>.

(c) *Tanks constructed of materials other than concrete or steel.* Tank assemblies, including fittings and access openings, constructed of materials other than concrete or steel shall be protected against deterioration due to internal and external environmental effects.

**(5) VENTING.** (a) Each tank, except camping unit transfer containers, shall be provided with a means of venting gases formed inside of the tank to the atmosphere.

(b) The tank vent shall terminate in accordance with s. Comm 82.31 (16).

**(6) PIPE CONNECTION.** All pipe connection openings to a tank shall be designed to allow connections in accordance with s. Comm 84.40.

**(7) ACCESS.** (a) Each covered tank shall be provided with one or more openings of sufficient size and located in such a manner to provide a means for inspection or required servicing or maintenance of the tank.

(b) Manhole openings shall be at least 23 inches in the least dimension.

(c) Anaerobic treatment tanks located below ground shall have a manhole opening over the inlet of the most upstream compartment, in each compartment, and over all treatment apparatuses and pumps.

(d) 1. Except as provided in subd. 2., manhole openings for anaerobic treatment tanks located below ground shall extend to a distance not greater than 6 inches below finished grade.

2. Manhole openings over all anaerobic treatment apparatuses and pumps shall extend to at least 4 inches above finished grade.

(e) Servicing and maintenance openings for holding components shall comply with all of the following:

1. Extend to at least 4 inches above finished grade.

2. Be at least 23 inches in the least dimension and be located above pumps or siphons located in the holding component.

(f) Inspection openings for tanks located below ground shall extend at least to the finished grade.

(g) Inspection, servicing and maintenance openings shall terminate with a means that prevents entrance of deleterious materials.

(h) Covers located at or above ground for openings larger than 8 inches in diameter shall be provided with locking devices and shall remain locked except for inspection, servicing or maintenance purposes.

**(8) WARNING LABEL.** (a) Covers for all tank openings larger than 8 inches in diameter shall be provided with a permanent

warning label indicating the dangers of entering the tank, in accordance with this subsection.

(b) The warning label shall be securely attached and made of a noncorrosive metal or plastic bearing the legend "DO NOT ENTER WITHOUT PROPER EQUIPMENT" or "DANGEROUS GASES EXIST IN TANK" or similar language.

(c) The label shall be rectangular in shape with minimum dimensions of 4 by 5 inches.

(d) The wording on the label shall be a minimum of ½ inch in height and be either indented or raised.

**(9) DOSING APPARATUS.** (a) Pumps for POWTS used to disperse air, treated wastewater or final effluent shall be rated by the pump manufacturer for such use.

(b) Siphons for POWTS shall be rated by the siphon manufacturer for wastewater use.

(c) All other dosing apparatus for POWTS shall be constructed of corrosion resistant materials and designed to perform as intended.

**(10) ALARM SYSTEM.** (a) All pump and alarm controls for POWTS shall be specifically designed by the manufacturer for such use.

(b) The use of pressure diaphragm switches in POWTS tanks shall be prohibited.

**(11) TANK LABEL.** (a) *Anaerobic treatment tanks.* Each treatment tank which has an anaerobic treatment compartment shall be labeled with a permanent label located near an inlet or outlet opening of the tank. The label shall be embossed, impressed, or securely attached to the tank. The label shall include all of the following information:

1. Name or trademark of the manufacturer.

2. Capacity of each compartment of the tank or the manufacturer's model number.

(b) *Aerobic treatment tanks.* 1. Each aerobic treatment tank complying with NSF Standard 40 and listed by a nationally recognized ANSI accredited third party certified listing agency acceptable to the department shall be provided with 2 label plates. The labels shall conform with all of the following:

a. Label plates shall be inscribed to be easily read and understood, and be securely attached.

b. One label plate shall be attached to the front of the electrical control box and the second label plate shall be attached to the aeration equipment assembly, tank, or riser at a location normally subject to access during inspection of the unit.

c. Each label plate shall include name or trademark of the manufacturer, model number, and rated daily flow capacity of the unit.

**Note:** See appendix section A-84.11 for acceptable listing agencies.

(c) *Other treatment, holding and combination treatment-holding tanks.* Except as required in par. (a) or (b), each treatment tank and holding tank shall be labeled with a permanent label located near an inlet or outlet opening. The label shall be embossed, impressed, or securely attached to the tank. The label shall include all of the following information:

1. Name or trademark of the manufacturer.

2. Capacity of each compartment of the tank or the manufacturer's model number.

**(12) OTHER TREATMENT COMPONENTS.** A treatment component not specifically covered in this section may not be sold for use in a POWTS or may not be installed in a POWTS, unless it has received department approval and conforms to the applicable performance standards of this chapter and chs. Comm 82 and 83, and ch. 145, Stats.

**History:** Cr. Register, April, 2000, No. 532, eff. 7-1-00; CR 02-129: r. and rec. (7) and (11) Register January 2004 No. 577, eff. 2-1-04.

**Comm 84.30 Plumbing materials. (1) GENERAL.** When selecting the material and determining size for a plumbing

system, due consideration shall be given to the waste that will discharge to the plumbing system and to the soil, liquid and atmospheric environments where the plumbing system will be located.

(a) The bending or offsetting of flexible or annealed pipe or tubing shall be in accordance with the applicable material standard or the instructions of the manufacturer of the pipe or tubing.

(b) Pipe or tubing with gouges, cuts or deep scratches may not be installed.

(c) Pipe or tubing which has been kinked may not be installed.

(d) The bending or offsetting of rigid pipe shall be prohibited.

(e) Nailing plates shall be installed to protect copper or plastic pipe or tubing from puncture.

(f) Pipe and tubing for water distribution systems downstream of treatment devices designed to serve fixtures, appliances and devices that provide  $\leq 1$  gpm at each outlet shall be sleeved when penetrating a wall, floor or structural member.

Note: See s. Comm 84.30 (4) (f) concerning the bending of polybutylene water distribution pipe and tubing.

(2) SANITARY DRAIN AND VENT SYSTEMS AND POWTS INSPECTION AND OBSERVATION PIPING. Sanitary drain systems and vent systems and POWTS inspection and observation piping shall be of such material and workmanship as set forth in this subsection.

(a) *Above ground drain and vent pipe.* Except as provided in s. Comm 82.33 (2), drain pipe and vent pipe installed above ground shall conform to one of the standards listed in Table 84.30-1.

(b) *Underground drain and vent pipe.* Except as provided in par. (d), drain pipe and vent pipe installed underground shall conform to one of the standards listed in Table 84.30-2.

(c) *Sanitary building sewer pipe.* Sanitary building sewer pipe shall conform to one of the standards listed in Table 84.30-3.

(d) *Treated wastewater piping.* 1. Nonpressurized, nonperforated drain piping conveying treated wastewater from a POWTS treatment or holding component to a POWTS treatment or holding component, distribution cell or dispersal zone shall conform to one of the standards listed in Table 84.30-3.

2. Nonpressurized perforated drain piping conveying treated wastewater in a POWTS soil treatment or dispersal component shall conform to one of the standards listed in Table 84.30-4.

3. Pressurized perforated drain piping conveying treated wastewater in a POWTS treatment or dispersal component shall conform to one of the standards listed in Table 84.30-5 and shall be perforated in accordance with the POWTS design.

(e) *Pressurized drain pipe.* Except as provided in par. (d) 3., pressurized drain pipe shall conform to one of the standards listed in Table 84.30-5 and shall be rated for the working pressure and temperature to which it will be subjected for a specific installation.

(f) *Chemical drain and vent pipe.* Drain systems and vent systems for chemical wastes shall be of approved corrosion resistant material. The manufacturer of the pipe shall indicate to the department the material's suitability for the concentrations of chemicals involved.

(g) *Catch basins, interceptors and sumps.* Catch basins, interceptors and sumps shall be constructed in a watertight manner of

precast reinforced concrete, reinforced monolithic concrete, cast iron, coated 12-gauge steel, vitrified clay, fiberglass, plastic or other approved materials.

(h) *Manholes.* Manholes shall be constructed in a watertight manner of precast reinforced concrete, reinforced monolithic concrete, brick or block, fiberglass or other approved materials. Fiberglass manholes may be approved for use in traffic areas if the top section of the manhole is not made of fiberglass.

(i) *Service suction lines.* A service suction line or pump discharge line serving a holding tank for cleaning purposes shall conform to one of the standards listed in Table 84.30-5. Joints and connections for suction lines shall conform to s. Comm 84.40. The use of mechanical joints shall be in accordance with the recommendations and instructions specified by the manufacturer.

(j) *POWTS inspection and observation pipe.* A POWTS inspection and observation pipe shall conform to at least one of the standards listed in Table 84.30-1.

**Table 84.30-1  
ABOVE GROUND DRAIN AND VENT PIPE AND TUBING**

Material	Standard
Acrylonitrile butadiene styrene (ABS)	ASTM D1527; ASTM D2661; ASTM F628
Brass	ASTM B43
Cast iron	ASTM A74; ASTM A888; CISPI 301
Copper	ASTM B42; ASTM B88; ASTM B306
Galvanized steel	ASTM A53
Polyvinyl chloride (PVC)	ASTM D2665; ASTM D1785; ASTM F891 <sup>b</sup>
Synthetic rubber hose <sup>a</sup>	AHAM DW-1

Note a: The installation of synthetic rubber hose is limited in use to indirect waste piping or local waste piping from dishwashers in accordance with s. Comm 82.33 (9) (d).

Note b: Limited to pipe weight of schedule 40.

**Table 84.30-2  
UNDERGROUND DRAIN AND VENT PIPE AND TUBING**

Material	Standard
Acrylonitrile butadiene styrene (ABS)	ASTM D1527; ASTM D2661; ASTM F628
Cast iron	ASTM A74; ASTM A888; CISPI 301
Concrete	ASTM C14; ASTM C76
Copper <sup>a</sup>	ASTM B42; ASTM B88
Polyvinyl chloride (PVC)	ASTM D1785; ASTM D2665; ASTM D3034 <sup>b</sup> ; ASTM F891 <sup>c</sup>
Vitrified clay	ASTM C700

Note a: Copper tubing, type M, may not be installed underground.

Note b: Limited to pipe with a SDR of 26 or less.

Note c: Limited to pipe weight of schedule 40.

**Table 84.30-3  
SANITARY BUILDING SEWER PIPE AND TUBING**

Material	Standard
Acrylonitrile butadiene styrene (ABS) <sup>a</sup>	ASTMD1527; ASTM D2661; ASTM D2751; ASTM F628
Acrylonitrile butadiene styrene (ABS) composite <sup>a</sup>	ASTM D2680
Cast iron	ASTM A74; ASTM A888; CISPI 301
Concrete	ASTM C14; ASTM C76
Copper <sup>b</sup>	ASTM B42; ASTM B88
Polyvinyl chloride (PVC) <sup>a</sup>	ASTM D1785; ASTM D2665; ASTM D3034; ASTM F891
PVC Corrugated Sewer Pipe With a Smooth Interior and Fittings	ASTM F949
PVC Large-Diameter Plastic Gravity Sewer Pipe and Fittings	ASTM F679
PVC Profile Gravity Sewer Pipe and Fittings Based on Controlled Inside Diameter	ASTM F794
Type PS-46 and Type PS-1 15 PVC Plastic Gravity Flow Sewer Pipe and Fittings	ASTM F789

<sup>a</sup>Thermoplastic sewer pipe shall be installed in accordance with ASTM D2321.

<sup>b</sup>Copper tubing, type M, may not be installed underground.

**Table 84.30-4  
PERFORATED EFFLUENT DISTRIBUTION PIPING  
FOR NONPRESSURIZED SOIL ABSORPTION  
SYSTEMS**

Material	Standard
Polyethylene (PE) <sup>a</sup>	ASTM F405; ASTM F810
Polyvinyl chloride (PVC) <sup>a</sup>	ASTM D2729

Note a: The pipe shall have 2 rows, and only 2 rows, of perforations parallel to the axis of the pipe and  $120^\circ \pm 5^\circ$  apart. The perforations shall be at the nominal 4 and 8 o'clock positions when the pipe is installed.

**Table 84.30-5  
PRESSURIZED DRAIN PIPE AND TUBING AND  
SERVICE SUCTION LINES**

Material	Standard
Acrylonitrile butadiene styrene (ABS) <sup>a</sup>	ASTM D1527; ASTM D2282; ASTM D2661; ASTM F628
Brass	ASTM B43
Chlorinated Poly (Vinyl Chloride) (CPVC) <sup>a</sup>	ASTM D2846; ASTM F441/F441M; ASTM F442/F442M
Concrete	ASTM C14; ASTM C76
Copper <sup>b</sup>	ASTM B42; ASTM B88; ASTM B306
Ductile iron	ASTM A377; AWWA C115/A21.15; AWWA C151/A21.51
Galvanized steel	ASTM A53
Polyvinyl chloride (PVC) <sup>a</sup>	ASTM D1785; ASTM D2241; ASTM D2665; AWWA C900
Polyethylene Pressure Pipe and Fitting, 4 in. through 63 in., for Water Distribution	AWWA C906
Stainless Steel	ANSI B36.19M; ASTM A270; ASTM A450

<sup>a</sup>Thermoplastic sewer pipe shall be installed in accordance with ASTM D2321.

<sup>b</sup>Copper tubing, type M, may not be installed underground.

(3) **STORM AND CLEAR WATER DRAIN AND VENT SYSTEMS.** Storm and clear water drain and vent systems shall be of such material and workmanship as set forth in this subsection.

(a) *Above ground drain and vent pipe.* Drain pipe and vent pipe installed above ground and inside a building shall conform to one of the standards listed in Table 84.30-1, except black steel pipe conforming to ASTM A53 may be used for storm water conductors. Black steel conductors may not be embedded in concrete or masonry.

(b) *Underground drain and vent pipe.* Drain pipe and vent pipe installed underground shall conform to one of the standards listed in Table 84.30-2.

(c) *Storm building sewer pipe.* Storm building sewer pipe shall conform to one of the standards listed in Table 84.30-6.

(d) *Subsoil drain pipe.* Subsoil drains shall be open jointed, horizontally split, or perforated pipe conforming to one of the standards listed in Table 84.30-7.

(e) *Roof drains.* 1. Roof drains shall be provided with removable strainers of sufficient strength to carry the anticipated loads.

2. Roof drains shall be so constructed that the drains can be cleaned and the drain inlets accessible at all time.

3. Roof drains shall be sized in accordance with s. Comm 82.36 and the drain outlet shall not be less than  $2\frac{1}{2}$  inches in diameter.

Note: See s. Comm 82.36 (18) for additional roof drain requirements.

(f) *Area drain inlets.* Area drain inlets shall be constructed in a watertight manner of precast concrete, reinforced monolithic concrete, brick or block, cast iron, coated 12 gauge steel, vitrified clay, fiberglass or other approved materials.

**Table 84.30-6**  
**STORM BUILDING SEWER PIPE AND TUBING**

Material	Standard
Acrylonitrile butadiene styrene (ABS) <sup>a</sup>	ASTM D1527; ASTM D2661; ASTM D2751; ASTM F628
Acrylonitrile butadiene styrene (ABS) composite <sup>a</sup>	ASTM D2680
Cast iron	ASTM A74; ASTM A888; CISPI 301
Concrete, circular	ASTM C14; ASTM C76
Concrete, elliptical	ASTM C507/C507M
Copper <sup>b</sup>	ASTM B42; ASTM B88
Polyvinyl chloride (PVC) <sup>a</sup>	ASTM D1785; ASTM D2665; ASTM D3034; ASTM F891
PVC Corrugated Sewer Pipe With a Smooth Interior and Fittings	ASTM F949
PVC Large-Diameter Plastic Gravity Sewer Pipe and Fittings	ASTM F679
PVC Profile Gravity Sewer Pipe and Fittings Based on Controlled Inside Diameter	ASTM F794
Type PS-46 and Type PS-1 15 PVC Plastic Gravity Flow Sewer Pipe and Fittings	ASTM F789
Vitrified clay	ASTM C700

<sup>a</sup> Thermoplastic sewer pipe shall be installed in accordance with ASTM D2321.

<sup>b</sup> Copper tubing, type M, may not be installed underground.

**(4) WATER SUPPLY SYSTEMS.** Water supply systems shall be of such material and workmanship as set forth in this subsection. All materials in contact with water, in a water supply system, shall be suitable for use with potable water. All pipes and pipe fittings for water supply systems shall be made of a material that contains not more than 8.0% lead.

(a) *Water quality.* A water supply system shall be resistive to corrosive action and degrading action from the water being conveyed.

(b) *Soil and groundwater.* The installation of water supply systems shall be prohibited in soil and groundwater that is contaminated with solvents, fuels, organic compounds or other detrimental materials which will cause permeation, corrosion, degradation, or structural failure of the piping material.

1. Where detrimental conditions are suspected, a chemical analysis of the soil and groundwater conditions shall be required to ascertain the acceptability of the proposed water supply system materials for the specific installation.

2. Where a detrimental condition exists, no underground water supply system may be installed until the detrimental condition can be:

- Eliminated and the source of the condition can be eliminated;
- Identified and the pipe and joining method can be proven resistant to the detrimental condition; or

c. Avoided by choosing an alternate route that will not be affected by the detrimental condition.

(c) *Certification of plastic pipe.* Plastic pipe for a water supply system shall be certified for potable water contact by a nationally recognized listing agency acceptable to the department.

Note: For a listing of nationally recognized agencies acceptable to the department, see Appendix A-84.11.

(d) *Water services and private water mains.* 1. Water service pipe and private water mains shall conform to one of the standards listed in Table 84.30-7. Pipe and tubing for water services and private water mains shall have a minimum working pressure of 150 psig at 73.4°F.

2. A local governmental unit may by ordinance restrict the types of materials for water services and private water mains which are to be located within or beneath an area subject to an easement for a highway, street or public service right-of-way. Before adopting an ordinance restricting the types of materials for water services, the local governmental unit shall submit a copy of the proposed ordinance to the department for review and approval.

(e) *Water distribution pipe.* 1. Except as provided in subd. 2. or 3., water distribution pipe shall have a minimum working pressure of 100 psig at 180°F and shall conform to one of the standards listed in Table 84.30-8.

2. Cold water distribution pipe installed underground shall have a minimum working pressure of 100 psig at 73.4°F and shall conform to one of the standards listed in Table 84.30-7 or 84.30-8.

Note: Portions of a water supply system that supply water to a water-based fire protection system are to also conform to chs. Comm 61 to 65.

Note: See appendix for further explanation.

3. Pipe and tubing for cold water distribution systems downstream of water treatment devices designed to serve fixtures, appliances and devices that provide  $\leq 1$  gpm at each outlet shall conform to one of the standards listed in Table 84.30-8 or 84.30-1 1, and shall have a minimum working pressure of 100 psig at 73.4°F.

4. Plastic pipe and tubing for water distribution systems downstream of water treatment devices designed to serve fixtures, appliances and devices that provide  $\leq 1$  gpm at each outlet shall be marked at intervals not to exceed 4 feet with the following information:

- The manufacturer's name.
- The trade designation of the pipe or tubing.
- The type of material.
- The minimum working temperature and pressure of the pipe or tubing.
- The mark of the certifying agency.

(f) *Bending limitations.* 1. The bending of polybutylene water service pipe or tubing shall be in accordance with the manufacturer's instructions.

2. a. The bending radius of polybutylene water distribution pipe or tubing shall meet or exceed the bending radius specified in Table 84.30-9 and shall meet or exceed the bending radius specified by the manufacturer of the pipe or tubing.

Note: See Appendix for further explanatory material.

b. Polybutylene water distribution pipe or tubing shall be supported or anchored at the beginning and end of long bends in accordance with the manufacturer's instructions.

**Table 84.30-7  
PIPE AND TUBING FOR  
WATER SERVICES AND PRIVATE WATER MAINS**

Material	Standard
Acrylonitrile butadiene styrene (ABS) <sup>a</sup>	ASTM D1527; ASTM D2282
Brass	ASTM B43
Chlorinated Poly (Vinyl Chloride) (CPVC) <sup>a</sup>	ASTM D2846; ASTM F441/F441M; ASTM F442/F442M
Copper <sup>b,c</sup>	ASTM B42; ASTM B88
Crosslinked Polyethylene/Aluminum/Crosslinked Polyethylene	CAN/CSA B137.10, ASTM F1281
Crosslinked polyethylene (PEX) <sup>a</sup>	ASTM F876; ASTM F877
Ductile iron	ASTM A377; AWWA C115/A21.15; AWWA C151/A21.51
Galvanized steel	ASTM A53
Polybutylene (PB) <sup>a</sup>	ASTM D2662; ASTM D2666; ASTM D3000; ASTM D3309
Polyethylene (PE) <sup>a</sup>	ASTM D2239; ASTM D2737; ASTM D2104; ASTM D2447; ASTM D3035, AWWA C906
Polyethylene/Aluminum/Polyethylene	CAN/CSA B137.9
Polyethylene/Aluminum/Polyethylene (PE-AL-PE) Composite Pressure Pipe	ASTM F1282
Polyvinyl chloride (PVC) <sup>a</sup>	ASTM D1785; ASTM D2241; AWWA C900
Stainless steel	ASME B36.19/B36.19M

<sup>a</sup>Plastic water service systems shall be installed in accordance with ASTM D2774.  
<sup>b</sup>Copper tubing, type M, may not be installed underground.  
<sup>c</sup>Copper pipe or tubing shall not be installed if the pH of the water to be conveyed is 6.5 or less.

**Table 84.30-8  
WATER DISTRIBUTION PIPE AND TUBING**

Material	Standard
Brass	ASTM B43
Cast iron	ASTM A377; AWWA C115/A21.15
Chlorinated Poly (Vinyl Chloride) (CPVC) <sup>a</sup>	ASTM D2846; ASTM F441/441c; ASTM F442/442M <sup>d</sup>
Copper <sup>b,e</sup>	ASTM B42; ASTM B88
Crosslinked Polyethylene/Aluminum/Crosslinked Polyethylene	CAN/CSA B137.10, ASTM F1281
Crosslinked polyethylene (PEX) <sup>a</sup>	ASTM F876; ASTM F877
Ductile iron	ASTM A377; AWWA C115/A21.15; AWWA C151/A21.51
Galvanized steel	ASTM A53
Polybutylene (PB) <sup>a</sup>	ASTM D3309
Polyethylene/Aluminum/Polyethylene	CAN/CSA B137.9
Polyethylene/Aluminum/Polyethylene (PE-AL-PE) Composite Pressure Pipe	ASTM F1281
Stainless Steel	ASME B36.19M; ASTM A270; ASTM A450

<sup>a</sup>Plastic pipe and tubing installed underground shall be in accordance with ASTM D2774.

<sup>b</sup>Copper tubing, type M, may not be installed underground.

<sup>c</sup>Use is limited to pipe 2½ inches or less in diameter.

<sup>d</sup>Use is limited to pipe with a SDR 11 or less.

<sup>e</sup>Copper pipe or tubing shall not be installed if the pH of the water to be conveyed is 6.5 or less.

**Table 84.30-9  
MINIMUM BENDING RADIUS OF POLYBUTYLENE  
WATER DISTRIBUTION PIPE AND TUBING**

Pipe Size (inches)	Bending Radius (inches)	Tubing Size (inches)	Bending Radius (inches)
¾	12¾	¼	4½
1	15¾	⅜	6
1¼	20	½	7½
1½	23	¾	10½
2	28½	1	13½
		1¼	16½
		1½	19½
		2	25½

<sup>a</sup>Plastic pipe and tubing installed underground shall be in accordance with ASTM D2774.

<sup>b</sup>Copper tubing, type M, may not be installed underground.

(g) *Circulating loops.* Polybutylene pipe and tubing may not be used for continuously circulating hot water loops.

(h) *Used piping.* Piping which has been used for any other purpose than conveying potable water may not be used for water supply systems.

(5) **PIPE FITTINGS AND VALVES.** (a) *Fittings.* Pipe fittings shall conform to the pipe material standards listed in this chapter or one of the standards listed in Table 84.30-10. Threaded drain pipe fittings shall be of the recessed drainage type.

(b) *Water supply valves.* 1. Control valves for water services and private water mains shall be designed and constructed to withstand a minimum pressure of 125 psig at 73.4°F.

2. Control valves for water distribution systems shall be designed and constructed to withstand a minimum pressure of 100 psig at 180°F.

3. Except for a valve integral to a device, a control valve which serves 2 or more plumbing fixtures shall have, with the valve in a fully open position, a flow through passageway of not less than one nominal pipe size smaller than the nominal size of the piping connecting to the valve.

4. A control valve which serves 2 or more plumbing fixtures may not be a globe type valve.

(c) *Special fittings and valves.* 1. Water hammer arrestors shall conform to ASME A112.26.1 or ASSE 1010.

2. Relief valves and automatic gas shutoff devices for hot water supply systems shall conform to ANSI Z21.22.

3. Backwater valves shall conform to ASME A112.14.1, CAN/CSA B181.1 or CAN/CSA B181.2.

4. Pipe applied atmospheric type vacuum breakers shall conform to ASSE 1001, and CAN/CSA B64.1.1.

5. Water pressure reducing valves and strainers for water pressure reducing valves for domestic water supply systems shall conform to ASSE 1003.

6. Hose connection vacuum breakers shall conform to ASSE 1011 or CAN/CSA B64.2.

7. Backflow preventers with intermediate atmospheric vent shall conform to ASSE 1012 and dual check type atmospheric port backflow preventers shall conform to CAN/CSA B64.3.

8. Reduced pressure principle backflow preventers shall conform with ASSE 1013 or CAN/CSA B64.4.

*Note:* Reduced pressure principle fire protection backflow preventers are not permitted for cross connection control.

9. Double check backflow prevention assemblies shall conform to ASSE 1015 or CAN/CSA B64.5.

*Note:* Double check fire protection backflow preventer assemblies are not permitted for cross connection control.

10. Individual thermostatic, pressure balancing, and combination pressure balancing and thermostatic control valves serving individual showers shall conform to ASSE 1016 or CAN/CSA B125.

11. Trap seal primer valves, water fed shall conform to ASSE 1018.

12. Vacuum breaker wall hydrants, freeze resistant automatic draining type shall conform to ASSE 1019, types A or B.

13. Pressure vacuum breaker assemblies shall conform to ASSE 1020 or CAN/CSA B64.1.2.

14. Laboratory faucet backflow preventers shall conform to ASSE 1035 and laboratory faucet type vacuum breakers shall conform to CAN/CSA B64.7.

15. Reduced pressure detector backflow preventers shall conform to ASSE 1047.

16. Double check detector assembly backflow preventers shall conform to ASSE 1048.

17. Back siphonage backflow vacuum breakers shall conform to ASSE 1056.

18. Hose connection backflow preventers shall conform to ASSE 1052.

19. Backflow preventers for carbonated beverage machines shall conform to ASSE 1022.

(d) *Pipe saddles.* Pipe saddles shall be installed in accordance with the instructions of the saddle manufacturer and conform to all of the following limitations:

1. Pipe saddles may be installed on private interceptor main sewers, building sewers, underground drain and vent pipe and tubing, and where otherwise approved by the department.

2. A saddle for drain piping shall have a radius in accordance with s. Comm 82.30 (8) (a).

3. The material of the saddle shall be compatible with the materials of the pipes which are to be connected to the saddle.

4. The hole in the pipe which is to receive the saddle shall be drilled or cored to match the saddle outlet.

5. Straps or clamps which wrap around the pipe and saddle shall be provided by the manufacturer of the saddle.

6. Saddles shall be installed with straps or clamps which wrap around the pipe and saddle.

7. Proper hangers or bedding shall be provided to maintain alignment between the opening in the pipe and the saddle.

**Table 84.30-10  
PIPE FITTINGS**

Material	Standard
Acrylonitrile butadiene styrene (ABS)	ASTM D2468; ASTM D3311; ASTM F409
Cast bronze	ANSI B16.15; ANSI B16.24
Cast copper alloy	ASME B16.18; ASME B16.23; ASME B16.26
Cast iron	ASME B16.4; ASME B16.12; ASME B16.1; ASME B16.45
Chlorinated polyvinyl chloride (CPVC)	ASTM F437; ASTM F438; ASTM F439
Copper	ASME B16.22; ASME B16.29
Crosslinked Polyethylene (PEX)	ASTM F1807
Ductile iron and gray iron	ANSI/AWWA C110/A21.10; ANSI/AWWA C153/A21.53; ANSI B16.42
Malleable iron	ANSI B16.3
Polybutylene (PB) <sup>c</sup>	ASTM D3309; MSS SP-103
Polyethylene (PE)	ASTM D2609; ASTM D2683; ASTM D3261
Polyvinyl Chloride (PVC)	ASTM D2464; ASTM D2466; ASTM D2467; ASTM D3311; ASTM F409; ASTM F1336; ASTM F1866
Polyvinyl Chloride (PVC) Gasketed Sewer Fittings	ASTM F1336
Stainless steel	ASTM A403
Steel <sup>a</sup>	ANSI B16.5; ANSI B16.9; ANSI B16.11; ANSI B16.28
Styrene-rubber (SR)	ASTM D2852

<sup>a</sup> Steel fittings and malleable iron fittings to be used in a water supply system shall be galvanized-coated in accordance with ASTM A123/123M.

<sup>b</sup> See s. Comm 84.30 (4) (intro.) concerning the maximum lead content for fittings.

<sup>c</sup> Copper and copper alloy fittings conforming to MSS SP-103, may not be installed underground.



**Table 84.30-11**  
**PIPE AND TUBING FOR WATER DISTRIBUTION**  
**SYSTEMS DOWNSTREAM OF TREATMENT**  
**DEVICES DESIGNED TO SERVE FIXTURES,**  
**APPLIANCES AND DEVICES THAT PROVIDE**  
**≤1 GPM AT EACH OUTLET**

Material	Standard
Copper <sup>b,c</sup>	ASTM B42; ASTM B88
Polyethylene (PE) <sup>a</sup>	NSF 51; NSF 61
Polypropylene (PP) <sup>a</sup>	NSF 51; NSF 61
Polyvinylidene fluoride (PVDF) <sup>a</sup>	NSF 51; NSF 61
Polyvinyl chloride (PVC) <sup>a</sup>	NSF 51; NSF 61

<sup>a</sup> These materials are approved for cold water use only.

<sup>b</sup> Copper tubing, Type M, shall not be installed underground.

<sup>c</sup> Copper pipe or tubing shall not be installed if the pH of the water to be conveyed is 6.5 or less.

(6) **SPECIAL MATERIALS.** (a) *Sheet lead.* Sheet lead for the following uses may not weigh less than indicated in subds. 1. and 2.

1. Site-fabricated flashings for vent pipes, 3 pounds per square foot; and
2. Prefabricated flashings for vent pipes, 2½ pounds per square foot.

(b) *Traps and fixture drain connection fittings.* Copper or tubular brass traps and fixture drain connection fittings shall be at least of 20 gage material.

(c) *Sheet copper.* Sheet copper for the following uses may not weigh less than indicated in subds. 1. and 2. and shall conform to ASTM B152.

1. Flashing for vent pipes, 8 ounces per square foot; and
2. Flush tank linings, 10 ounces per square foot.

(d) *Cleanout plugs.* Cleanout plugs shall be of brass or plastic. Brass cleanout plugs shall be used with metallic piping only and shall conform to ASTM A74. Plastic cleanout plugs shall conform to the requirements of sub. (5) (a).

(e) *Flush pipes and fittings.* Flush pipes and fittings shall be of nonferrous material and shall conform to ASME A112.19.5.

(f) *Safing material.* Safing materials shall be waterproof when subjected to 2 feet of hydrostatic head when tested in accordance with ASTM C1306 or ASTM D4068. The material shall be recognized by the manufacturer for use as a safing material.

(g) *Geotextile fabrics.* Geotextile fabric used in a POWTS to prevent backfill material from entering the distribution cell shall meet the requirements listed in Table 84.30-12.

**Table 84.30-12**  
**GEOTEXTILE FABRICS**

Property	Test Method	Minimum Average Roll Value
Grab Tensile, lbs	ASTM D4632	35 lbs, minimum
Grab Elongation, %	ASTM D4632	50%, minimum
Puncture, lbs	ASTM D4833	10 lbs, minimum
Trapezoidal tear, lbs	ASTM D4533	11 lbs, minimum
AOS, US Sieve #	ASTM D4751	20 US sieve #, minimum
AOS, US Sieve #	ASTM D4751	70 US sieve #, maximum

(h) *Leaching chambers.* Leaching chambers for distribution cell components of POWTS shall meet all of the following requirements:

1. Constructed of corrosion resistant materials.
2. Designed to prevent soil surrounding the chamber from entering the chamber.
3. Capable of withstanding pressures that the leaching chamber is intended to encounter.

(i) *Stone aggregate.* Stone aggregate which is used as a filtering medium or to create a distribution cell in a treatment or dispersal component of a POWTS shall meet all of the following requirements:

1. Conform to ASTM Standard C33 for coarse aggregate prior to washing.
2. Be washed to remove fine material.
3. Be ½ to 2½ inch in size.
4. Have a hardness value of at least 3 on Moh's Scale of Hardness.

**Note:** Stone that can scratch a copper penny without leaving any residual stone material on the penny has a hardness value of at least 3 on Moh's Scale of Hardness.

(j) *Sand.* Sand which is used as a filtering medium in a treatment or distribution cell of a POWTS shall conform to ASTM Standard C33 for fine aggregate.

**History:** Cr. Register, May, 1988, No. 389, eff. 6-1-88; am. (4) (intro.), Register, August, 1988, No. 392, eff. 9-1-88; renum. (2) (e) to (g) to (f) to (h), cr. (2) (e), am. Table 84.30-4, r. and rec. Table 84.30-5, Register, August, 1991, No. 428, eff. 9-1-91; am. (2) (c), (d) 1. and (e), r. (2) (d) 3., renum. (2) (d) 4. to be (2) (d) 3., cr. (2) (i), Register, April, 1992, No. 436, eff. 5-1-92; am. (3) (a), Tables 1, 3 to 9, 10 and 11, Register, September, 1992, No. 441, eff. 10-1-92; am. Table 84.30-9, cr. (4) (g), Register, September, 1993, No. 453, eff. 10-1-93; am. Tables 84.30-2, 84.30-3, 84.30-6, 84.30-8 and 84.30-9, r. Table 84.30-10a, (6) (a) 1. and (c) 1., cr. (4) (h) and (5) (b) 4., r. and rec. (5) (b) 3., (c) and (6) (f), renum. (6) (a) 2. and 3. and (c) 2. and 3. to be (6) (a) 1. and 2. and (c) 1. and 2., Register, February, 1994, No. 458, eff. 3-1-94; correction in (6) (a) (intro.) made under s. 13.93 (2m) (b) 7, Stats., Register, February, 1994, No. 458; am. Table 84.30-1, (5) (c) 7., 11., 12., 13, 14., cr. (5) (c) 16., 17., Register, February, 1997, No. 494, eff. 3-1-97; am. Tables 84.30-5 and 84.30-9, cr. (6) (g) to (j) and Table 84.30-12 and r. and rec. (2) (d), Register, April, 2000, No. 532, eff. 7-1-00 except Table 84.30-9, eff. 5-1-00; cr. (5) (c) 10., renum. (5) (c) 10. to 17., to be (5) (c) 11. to 18. and am. (5) (c) 1., 3., 4., 6. to 9., am. Tables 84.30-3, 5, 6, 8, 9, 10 and 11; Register, December, 2000, No. 540, eff. 1-1-01; reprinted to correct printing error in Table 84.30-1, Register, April, 2001, No. 544; CR 02-002: r. and rec. (1) (intro.), cr. (1) (f), (2) (j), (4) (i), and Table 84.30-11, am. (2) (intro.), (4) (c) to (e), (f) 2. a., (5) (a), (b) 3., (d) and Tables 84.30-1 to 6, r. Tables 84.30-7 and 10, renum. Tables 84.30-8 to 9m and 11 to be Tables 84.30-7 to 10 and am. Register April 2003 No. 568, eff. 5-1-03; CR 02-129: am. (2) (j) and (4) (e) 2., renum. (4) (d) to be (4) (d) 1., cr. (4) (d) 2. and (4) (e) 4., r. and rec. (4) (e) 3., r. (4) (i) Register January 2004 No. 577, eff. 2-1-04.

#### Comm 84.40 Joints and connections. (1) GENERAL.

(a) *Tightness.* Joints and connections in the plumbing system shall be watertight and gastight as required by test or system design, whichever is greater, or as required by the adopted product standard or department approval.

**Note:** The testing requirements for tightness are in s. Comm 82.21.

(b) *Preparation of pipe ends.* Pipe ends shall be prepared in accordance with the applicable pipe standard or the pipe or fitting manufacturer's instructions.

(c) *Prohibited joints and connections.* Unless otherwise permitted in this chapter or ch. Comm 82 or 83, all of the following types of joints and connections shall be prohibited:

1. Cement or concrete joints.
2. Mastic or hot poured bituminous joints.
3. Elastomeric rolling o-rings between different diameter pipes.
4. Solvent cement joints between different types of plastic pipe other than ABS and PVC in non-pressurized systems.
5. Roll grooving of galvanized steel pipe.

(2) **ABS PLASTIC PIPE.** Joints between acrylonitrile butadiene styrene plastic pipe or fittings shall be installed in accordance with pars. (a) to (c).

(a) *Mechanical joints.* Mechanical joints shall be installed in accordance with the manufacturer's instructions.

1. Drain and vent systems. Mechanical push-on joints for drain and vent systems shall conform to ASTM D3212.

2. Water supply systems. Mechanical push-on joints and mechanical compression-type joints for water supply systems which use a flexible elastomeric seal shall conform to ASTM D3139.

(b) *Solvent cemented joints.* Solvent cemented joints shall be made in accordance with ASTM D2235 and its appendix, ASTM D2661 or ASTM F628.

1. Joint surfaces shall be clean and free of moisture.

2. Solvent cement conforming to ASTM D2235 shall be applied to all joint surfaces and the joint shall be made while the cement is wet.

3. Solvent cement shall be handled in accordance with ASTM F402.

4. Solvent cement used on pipes and fittings of a water supply system shall conform to NSF 14 and shall be certified by a nationally recognized testing agency as to conforming to NSF 14. The container for the solvent cement shall bear the certification mark of the testing agency.

(c) *Threaded joints.* Threaded joints shall only be used on pipes of schedule 80 or heavier. Threaded joints shall conform to ASME B1.20.1. The pipe shall be threaded with dies specifically designed for plastic pipe. Thread lubricant or tape approved for such use shall be applied to the male threads only.

(3) **BLACK STEEL PIPE.** Joints between black steel pipe or fittings shall be in accordance with pars. (a) to (d).

(a) *Threaded joints.* Threaded joints shall conform to ASME B1.20.1. Pipe joint compound or tape shall be used on the male threads only.

(b) *Mechanical joints.* Mechanical joints shall be installed in accordance with the manufacturer's instructions.

(c) *Caulked joints.* Caulked joints shall only be used for drain or vent piping. Caulked joints for hub and spigot piping and fittings shall be firmly packed with oakum or hemp. Molten lead shall be poured in one operation not less than one inch deep and not to extend more than 1/8 inch below the rim of the pipe, and caulked tight. Paint, varnish or other coatings may not be used on the joining material until after the joint has been tested and approved.

1. Caulked joints for drain piping shall be used only in a vertical position.

2. Caulked joints for vent piping may be used for piping in a vertical or horizontal position.

(d) *Welded joints.* Joints between black steel pipe or fittings may be welded.

(4) **BRASS PIPE.** Joints between brass pipe or fittings shall be in accordance with the provisions of pars. (a) to (d).

(a) *Brazed joints.* All joint surfaces to be brazed shall be cleaned bright by other than chemical means. Brazing filler metal conforming to AWS A5.8 or other approved material shall be used. The joining of water supply piping shall be made with lead-free materials. Solders and fluxes containing in excess of 0.2% lead shall not be used.

(b) *Mechanical joints.* Mechanical joints shall be installed in accordance with the manufacturer's instructions. Mechanical push-on joints and mechanical compression type joints for water supply systems which use flexible elastomeric seals shall conform to ASTM D3139.

(c) *Soldered joints.* All joint surfaces to be soldered shall be cleaned bright by other than chemical means. A nontoxic flux shall be applied to all joint surfaces. Solder conforming to ASTM B32 or other approved material shall be used. The joining of water supply piping shall be made with lead-free materials. Solders and fluxes containing in excess of 0.2% lead shall not be used.

(d) *Threaded joints.* Threaded joints shall conform to ASME B1.20.1. Pipe joint compound or tape shall be used on the male threads only.

(5) **CAST IRON PIPE.** Joints between cast iron pipe or fittings shall be installed in accordance with pars. (a) and (b).

(a) *Caulked joints.* 1. Drain and vent systems. Caulked joints for hub and spigot pipe of drain and vent systems shall be firmly packed with oakum or hemp. Molten lead shall be poured in one operation not less than one inch deep and not to extend more than 1/8 inch below the rim of the pipe, and caulked tight. Paint, varnish or other coatings may not be used on the joining material until after the joint has been tested and approved.

2. Water supply systems. Joints for bell and spigot pipe of water supply systems shall be firmly packed with treated paper rope. Molten lead shall be poured in one operation to a depth of 2 1/2 inches.

(b) *Mechanical joints.* 1. Drain and vent systems. a. Mechanical push-on joints for drain and vent systems shall have gaskets which conform to ASTM C564.

b. Mechanical sleeve joints for drain and vent systems shall have a rubber sealing sleeve conforming to ASTM C564, CISPI 310 or FM 1680. Where a stainless steel band assembly is used, the band assembly shall conform to CISPI 310 or FM 1680. Mechanical joints shall be installed in accordance with the manufacturer's instructions.

2. Water supply systems. Mechanical push-on joints and mechanical compression type joints for water supply systems shall conform to AWWA C111/A21.11. Lead tipped gaskets may not be used.

(c) *Threaded joints.* Threaded joints shall conform to ANSI B1.20.1. Pipe joint compound or tape shall be used on the male threads only.

(6) **CPVC PLASTIC PIPE.** Joints between chlorinated polyvinyl chloride plastic pipe or fittings shall be installed in accordance with the provisions of pars. (a) to (c).

(a) *Mechanical joints.* Mechanical joints shall be installed in accordance with the manufacturer's instructions. Mechanical push-on type joints which use flexible elastomeric seals shall conform to ASTM D3139.

(b) *Solvent cemented joints.* Solvent cemented joints shall be made in accordance with ASTM D2846 or ASTM F493.

1. Joint surfaces shall be clean and free of moisture. Cleaner, primer and cement shall be installed in accordance with the manufacturer's instructions for use of the solvent cement.

2. Solvent cement conforming to ASTM F493 shall be applied to all joint surfaces and the joint shall be made while the cement is wet.

3. Solvent cement shall be handled in accordance with ASTM F402.

4. Primer and solvent cement used on pipes and fittings of a water supply system shall conform to NSF 14 and shall be certified by a nationally recognized testing agency as to conforming to NSF 14. The containers for the primer and the solvent cement shall bear the certification mark of the testing agency.

(c) *Threaded joints.* Threaded joints shall only be used on pipes of schedule 80 or heavier. Threaded joints shall conform to ANSI B1.20.1. The pipe shall be threaded with dies specifically designed for plastic pipe. Thread lubricant or tape approved for such use shall be applied to the male threads only.

(7) **CONCRETE PIPE.** (a) *Circular pipe.* Joints between circular concrete pipe or fittings shall be made by use of an elastomeric seal conforming to ASTM C443 or C990.

(b) *Elliptical pipe.* Joints between elliptical concrete pipe or fittings shall be made by use of materials conforming to ASTM C887 Type II or ASTM C990.

**(8) COPPER PIPE AND TUBING.** Joints between copper pipe, tubing or fittings shall be installed in accordance with pars. (a) to (e).

(a) *Brazed joints.* All joint surfaces to be brazed shall be cleaned bright by other than chemical means. Brazing filler metal conforming to AWS A5.8 or other approved material shall be used. The joining of water supply piping shall be made with lead-free materials.

(b) *Flared joints.* Flared joints may be used on annealed tubing for water supply systems and shall be made by the use of a tool designed for that operation.

(c) *Mechanical joints.* Mechanical joints shall be installed in accordance with the manufacturer's instructions. Mechanical push-on joints and mechanical compression type joints for water supply systems which use flexible elastomeric seals shall conform to ASTM D3139.

(d) *Soldered joints.* All joint surfaces to be soldered shall be made in accordance with ASTM B828. Flux approved by NSF for use in potable water systems shall be applied to all joint surfaces. Solder conforming to ASTM B32 or other approved material shall be used. The joining of water supply piping shall be made with lead-free materials.

(e) *Threaded joints.* Threaded joints shall conform to ANSI B1.20.1. Pipe joint compound or tape shall be used on the male threads only.

**(9) DUCTILE IRON PIPE.** (a) *Mechanical joints.* Mechanical push-on joints and mechanical compression type joints for water supply systems shall conform to AWWA C111/A21.11. Lead tipped gaskets may not be used.

(b) *Threaded joints.* Threaded joints shall conform to ASME B1.20.1. Pipe joint compound or tape shall be used on the male threads only.

**(10) GALVANIZED STEEL PIPE.** Joints between galvanized steel pipe or fittings or between galvanized steel pipe and cast iron fittings shall be installed in accordance with pars. (a) to (c).

(a) *Threaded joints.* Threaded joints shall conform to ASME B1.20.1. Pipe joint compound or tape shall be used on the male threads only.

(b) *Mechanical joints.* Mechanical joints shall be installed in accordance with the manufacturer's instructions. Mechanical push-on joints and mechanical compression type joints for water supply systems which use flexible elastomeric seals shall conform to ASTM D3139.

(c) *Caulked joints.* Caulked joints shall only be used for drain or vent piping. Caulked joints for hub and spigot piping and fittings shall be firmly packed with oakum or hemp. Molten lead shall be poured in one operation not less than one inch deep and not to extend more than  $\frac{1}{8}$  inch below the rim of the pipe, and caulked tight. Paint, varnish or other coatings may not be used on the joining material until after the joint has been tested and approved.

1. Caulked joints for drain piping shall be used only for piping in a vertical position.

2. Caulked joints for vent piping may be used for piping in a vertical or horizontal position.

**(11) LEAD PIPE.** Joints between lead pipe or fittings shall be installed in accordance with pars. (a) and (b).

(a) *Burned joints.* Burned joints shall be uniformly fused together into one continuous piece. The thickness of the joint shall be at least as thick as the lead being joined. The filler metal shall be of the same material as the pipe.

(b) *Wiped joints.* A wiped joint shall be full wiped, having an exposed surface on each side of the joint not less than  $\frac{3}{4}$  inch and shall be at least  $\frac{3}{8}$  inch thick at the thickest point.

**(12) PB PLASTIC PIPE AND TUBING.** Joints between polybutylene plastic pipe and tubing or fittings shall be installed in accordance with pars. (a) to (c).

(a) *Flared joints.* Flared joints shall be made by use of a tool designed for that operation. Flared joints shall be made in accordance with ASTM D3140.

(b) *Heat fusion joints.* Heat fusion joints shall be made in accordance with ASTM D2657 and ASTM D3309. Heat fusion joints shall be of a socket fusion type.

1. Joint surfaces to be fused shall be clean and free of moisture.

2. All joint surfaces shall be heated to the temperature recommended by the pipe or fitting manufacturer and joined.

3. The joint shall be undisturbed until cool.

(c) *Mechanical joints.* Mechanical joints shall be installed in accordance with the manufacturer's instructions. Mechanical push-on joints and mechanical compression type joints which use flexible elastomeric seals shall conform to ASTM D3139.

**(13) PE PLASTIC PIPE AND TUBING.** Joints between polyethylene plastic pipe, tubing or fittings shall be in accordance with pars. (a) to (c).

(a) *Flared joints.* Flared joints shall be made by use of a tool designed for that operation. Flared joints shall be made in accordance with ASTM D3140.

(b) *Heat fusion joints.* Heat fusion joints shall be made in accordance with ASTM D2657. Heat fusion joints shall be of a socket fusion type.

1. Joint surfaces to be fused shall be clean and free of moisture.

2. All joint surfaces shall be heated to the temperature recommended by the pipe or fitting manufacturer and joined.

3. The joint shall be undisturbed until cool.

(c) *Mechanical joints.* Mechanical joints may be installed in accordance with the manufacturer's instructions. Mechanical push-on joints and mechanical compression type joints which use flexible elastomeric seals shall conform to ASTM D3139.

**(13m) PEX PLASTIC TUBING.** Joints between crosslinked polyethylene plastic pipe, tubing or fittings shall be made in accordance with the manufacturer's instructions.

**(14) PVC PLASTIC PIPE.** Joints between polyvinyl chloride plastic pipe or fittings shall be in accordance with pars. (a) to (c).

(a) *Mechanical joints.* Mechanical joints shall be installed in accordance with the manufacturer's instructions.

1. Drain and vent systems. Mechanical push-on joints for drain and vent systems shall conform to ASTM D3212.

2. Water supply systems. Mechanical push-on joints and mechanical compression type joints for water supply systems which use flexible elastomeric seals shall conform to ASTM D3139.

(b) *Solvent cemented joints.* Solvent cemented joints shall be made in accordance with ASTM D2855.

1. Joint surfaces shall be clean and free of moisture. A primer conforming to ASTM F656 shall be applied to all joint surfaces.

2. Solvent cement conforming to ASTM D2564 shall be applied to all joint surfaces and the joint shall be made while the cement is wet.

3. Solvent cement shall be handled in accordance with ASTM F402.

4. Primer and solvent cement used on pipes and fittings of a water supply system shall conform to NSF 14 and shall be certified by a nationally recognized testing agency as to conforming to NSF 14. The containers for the primer and the solvent cement shall bear the certification mark of the testing agency.

(c) *Threaded joints.* Threaded joints shall only be used on pipes of schedule 80 or heavier. Threaded joints shall conform to ASME B1.20.1. The pipe shall be threaded with dies specifically designed for plastic pipe. Thread lubricant or tape approved for such use shall be applied to the male threads only.

**(15) STAINLESS STEEL.** Joints between stainless steel pipe or fittings shall be installed in accordance with the provisions of pars. (a) to (c).

(a) *Mechanical joints.* Mechanical joints shall be installed in accordance with the manufacturer's instructions. Mechanical push-on type joints which use flexible elastomeric seals shall conform to ASTM D3139.

(b) *Threaded joints.* Threaded joints shall conform to ANSI B1.20.1. Pipe joint compound or tape shall be used on the male threads only.

(c) *Welded joints.* Joints between stainless steel pipe or fittings may be welded.

**(16) VITRIFIED CLAY PIPE.** Joints between vitrified clay pipe or fittings shall be made by use of elastomeric seals conforming to ASTM C425.

**(17) JOINTS BETWEEN PIPE AND FITTINGS OF DIFFERENT MATERIALS.** Connections between pipes of different materials shall be made with mechanical compression type joints, installed in accordance with manufacturer's instructions or as specified in pars. (a) to (e).

(a) *Copper to cast iron.* Connections between copper pipe or tube and cast iron pipe shall be by means of either caulked joints in accordance with sub. (5) (a) or threaded fittings in accordance with sub. (5) (c).

(b) *Copper to galvanized steel.* Connections between copper pipe or tube and galvanized steel pipe shall be by use of an adapter fitting. The copper pipe shall be soldered to the adapter in accordance with sub. (8) (d). The galvanized steel shall be threaded to the adapter in accordance with sub. (10) (a).

(c) *Cast iron to steel or brass pipe.* Connections between cast iron pipe and galvanized or black steel or brass pipe shall be by means of:

1. Caulked joints in accordance with sub. (5) (a); or
2. Threaded joints in accordance with sub. (5) (c).

(d) *Plastic to other materials.* 1. Connections between plastic pipe and cast iron pipe shall be by means of:

- a. Caulked joints in accordance with sub. (5) (a); or
- b. Threaded joints in accordance with sub. (5) (c).

2. Except as provided in par. (f), connections between different types of plastic pipe or between plastic pipe and other piping materials other than cast iron shall be by means of threaded joints in accordance with sub. (14) (c).

(e) *Lead to other piping materials.* Connections between lead pipe and other piping materials shall be by use of an adapter fitting conforming to s. Comm 84.30 (5) (a). The lead pipe shall be caulked or burned to the adapter fitting in accordance with sub. (11).

(f) *ABS plastic to PVC plastic.* For solvent-cemented connections between ABS and PVC piping in non-pressurized systems, all of the following shall apply:

1. Joint surfaces shall be clean and free of moisture.
2. Primer conforming to ASTM F656 shall be applied to all PVC joint surfaces.
3. Solvent conforming to ASTM D3138 shall be applied to all joint surfaces and the joint shall be made while the cement is wet.
4. Solvent shall be handled in accordance with ASTM F402.

**(18) CONNECTION OF FIXTURES.** Flanged fixtures which have integral traps shall be mechanically fastened to the drain piping by means of a compatible fitting. The joint between the fixture and the fitting shall be sealed with a watertight gasket or setting compound.

**(19) CONNECTION OF PIPE TO CONCRETE STRUCTURES.** Joints between concrete structures and piping shall be made with mechanical joints in conformance with ASTM C923, ASTM C564 or as otherwise permitted by local authority. Openings for pipe connections that are installed with mechanical joints con-

forming to ASTM C564 shall have an inside diameter of that required for cast iron pipe in conformance with ASTM A74.

**History:** Cr. Register, May, 1988, No. 389, eff. 6-1-88; am. (5) (b) 1. b., Register, September, 1992, No. 441, eff. 10-1-92; am. (1) (a) and cr. (13m), Register, February, 1994, No. 458, eff. 3-1-94; am. (2) (c), (3) (a), (4) (a), (c) and (d), (8) (a), (d), (9) (b), (10) (a) and (14) (c), renum. (7) to be (7) (a), cr. (7) (b); Register, December, 2000, No. 540, eff. 1-1-01; CR 02-002: am. (1) (c) 1. to 4., (6) (b) (intro.) and L., (8) (d), (17) (d) 2., r. (6) (b) 4., renum. (6) (b) 5. to be (6) (b) 4., cr. (17) (f) and (19), Register April 2003 No. 568, eff. 5-1-03.

**Comm 84.50 Alternate approvals and experimental approvals. (1) GENERAL.** The provisions of chs. Comm 82 to 84 are not intended to prevent the use of a plumbing material or product not specifically addressed therein if the plumbing material or product has been approved by the department.

**(2) ALTERNATE APPROVAL.** (a) Plumbing materials or products determined by the department to comply with the intent of chs. Comm 82 to 84 and ch. 145, Stats., and not approved under s. Comm 84.10, shall be issued an alternate approval. Alternate approvals shall be issued by the department in writing.

(b) The department may require the submission of any information deemed necessary for review. Sufficient evidence shall be submitted to the department to substantiate:

1. Assertions of function and performance; and
2. Compliance with the intent of chs. Comm 82 to 84 and ch. 145, Stats.

(c) The department shall review and make a determination on an application for alternate approval within 3 months of receipt of all information and fees required to complete the review.

(d) The department may impose specific conditions in issuing an alternate approval, including an expiration date for the alternate approval. Violations of the conditions under which an alternate approval is issued shall constitute a violation of this chapter.

(e) If, upon review, the department determines that a plumbing material or product does not comply with the intent of chs. Comm 82 to 84 and ch. 145, Stats., the request for alternate approval shall be denied in writing.

**(3) EXPERIMENTAL APPROVAL.** (a) The department may allow the installation of a plumbing material or product for the purpose of proving compliance with the intent of chs. Comm 82 to 84 and ch. 145, Stats.

(b) An experimental approval shall be required for each plumbing material or product to be installed for the purpose of proving compliance with the intent of chs. Comm 82 to 84 and ch. 145, Stats. A separate experimental approval shall be obtained for each project where such a product is to be used. Experimental approvals shall be issued by the department in writing. Experimental approvals shall be denied by the department in writing.

(c) The department may require the submission of any information deemed necessary for review.

(d) The department may limit the number of applications it will accept for experimental approval of products.

(e) The department shall review and make a determination on an application for experimental approval within 6 months of receipt of all information and fees required to complete the review.

(f) The department may impose specific conditions in issuing an experimental approval. Violations of the conditions under which an experimental approval is issued shall constitute a violation of this chapter.

(g) If the department issues an experimental approval:

1. Plans detailing the installation of the plumbing material or product shall be submitted to the department in accordance with s. Comm 82.20 (4) or 83.22.

2. A copy of the experimental approval shall be attached to the submitted plans and approved plans.

3. A letter of consent from the owner of the installation shall be attached to the submitted plans and approved plans. The letter shall acknowledge that the owner has received and read a copy of the experimental approval and s. Comm 84.50.

4. The completed installation shall be inspected for compliance with the approved plans by the department. A report on the completed installation shall be written by the department.

5. A written report, from the party who was issued the experimental approval, shall be submitted to the department detailing the function and performance of the installed plumbing material or product. The report shall be completed at time intervals specified by the department, but not less than once a year.

6. On-site inspections shall be performed by the department at time intervals specified by the department, but not less than once a year. A report on the inspection shall be written by the department. The department may assess a fee for the inspection.

7. Five years after the date of the completed installation the department shall within 6 months order the removal of the plumbing material or product, issue an approval, or renew the experimental approval for another 5-year period to obtain additional information to determine the result of the experiment.

(h) If chs. Comm 82 to 84 or ch. 145, Stats., are revised to include or permit an experimental plumbing material or product to conform with the intent of chs. Comm 82 to 84 and ch. 145, Stats., the department shall waive the requirements of par. (f) as to that material or product.

**(4) MODIFICATIONS.** If a plumbing material or product with an alternate or experimental approval or the installation of an experimentally approved plumbing material or product is modified or additional assertions of function or performance are made, the alternate or experimental approval shall be considered null and void, unless the product is resubmitted to the department for review and the approval is reaffirmed.

**(5) REVOCATION.** The department may revoke an alternate or experimental approval issued under this section for any false statements or misrepresentations of facts or data on which the alternate or experimental approval was based or as a result of product failure.

**(6) LIMITATIONS.** An alternate or experimental approval of a plumbing material or product issued by the department may not be construed as an assumption of any responsibility for defects in design, construction, or performance of any plumbing material or product nor for any damages that may result.

**(7) FEES.** Fees for the review of a plumbing material or product under this section and any required on-site inspections shall be submitted in accordance with ch. Comm 2.

**History:** Cr. Register, May, 1988, No. 389, eff. 6-1-88; correction in (7) made under s. 13.93 (2m) (b) 7., Stats., Register, August, 1988, No. 392; correction in (7) made under s. 13.93 (2m) (b) 7., Stats., Register, February, 1994, No. 458; am. (3) (g) 1. and 7., Register, April, 2000, No. 532, eff. 7-1-00.



## Chapter Comm 84

### APPENDIX

---

The material contained in this appendix is for clarification purposes only. The notes, illustrations, etc., are numbered to correspond to the number of the rule as it appears in the text of the code.

**A-84.10 (3) (b)** Request forms for voluntary POWTS product approval may be obtained at the following location:

Department of Commerce  
Madison Office  
201 W. Washington Ave.  
PO Box 7162  
Madison, WI 53707-7162  
Phone (608) 266-6742  
Web Page <http://www.commerce.state.wi.us/SB/SB-DivForms.html>

#### **A-84.11 - Nationally Recognized Listing Agencies Acceptable to the Department**

American Gas Association (AGA)  
400 N. Capitol Street, N.W.  
Washington, DC 20001  
Phone (202) 824-7000  
Web Page [www.aga.org](http://www.aga.org)

American Society of Mechanical Engineers (ASME)  
Three Park Avenue  
New York, NY 10016-5990  
Phone (212) 524-4990  
Web Page [www.asme.org](http://www.asme.org)

American Society of Sanitary Engineering (ASSE)  
901 Canterbury, Suite A  
Westlake, OH 44145-1166  
Phone (440) 835-3040  
Web Page [www.asse-plumbing.org](http://www.asse-plumbing.org)

Canadian Standards Association International (CSA)  
178 Rexdale Blvd.  
Toronto, ON  
CANADA  
M9W 1R3  
Phone (800) 463-6727  
Web Page [www.csa-international.org](http://www.csa-international.org)

IAPMO Research and Testing, Inc. (IAPMO)  
5001 E. Philadelphia St.  
Ontario, CA 91761  
Phone (909) 472-4100  
Web Page [www.iapmo.org/rnt](http://www.iapmo.org/rnt)

ETL Intertek Testing Services NAE, Inc. (ITS)  
3233 US Route 11  
Cortland, NY 13045  
Phone (607) 753-6711  
Web Page [www.intertek-testing.com](http://www.intertek-testing.com)  
Web Page [www.etlsemko.com](http://www.etlsemko.com)

NSF *International* (NSF)  
789 Dixboro Rd.  
Ann Arbor, MI 48105-9723  
Phone (800) 673-6275  
Web Page [www.nsf.org](http://www.nsf.org)

Underwriters Laboratories Inc. (UL)  
333 Pfingsten Rd.  
Northbrook, IL 60062-2096  
Phone (847) 272-8800  
Web Page [www.ul.com](http://www.ul.com)

The listing agencies list products to a specific national standard and have labeling requirements in addition to those requirements of the standard., i.e., ASSE requires that their seal with the standard number be on the device.



**A-84.20 (5) SPACING OF PLUMBING FIXTURES**

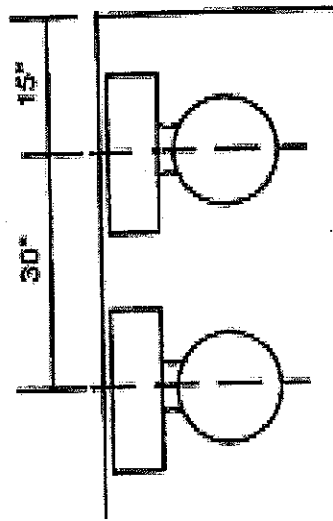

Figure A-84.20-1. Spacing between water closets.

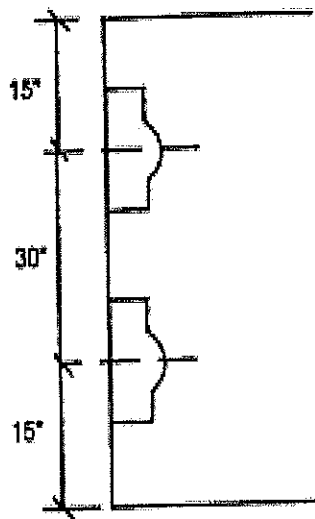

Figure A-84.20-2. Spacing between stall type urinals.

**A-84.20 (5) SPACING OF PLUMBING FIXTURES (Continued)**

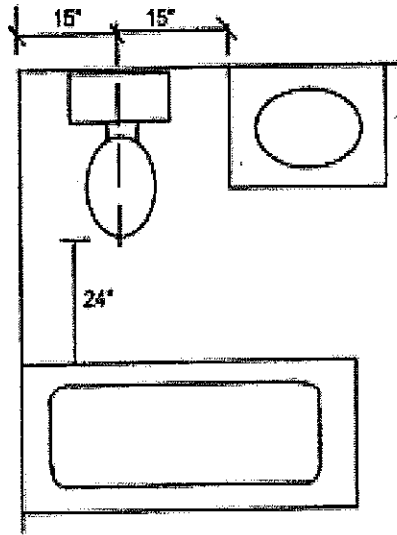
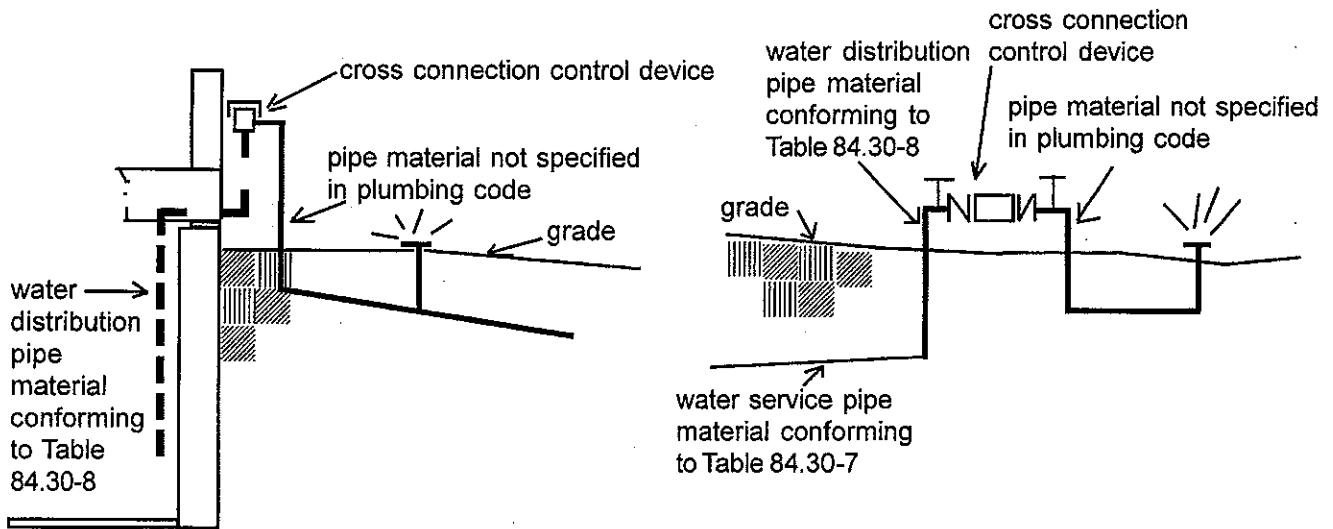

Figure A-84.20-3. Spacing between water closet and tub.

**A-84.30 (4) (e) 2. TURF SPRINKLER SYSTEM PIPING MATERIAL.**



**Turf sprinkler system piping material**

## Chapter Comm 85

### SOIL AND SITE EVALUATIONS

Comm 85.01	Purpose.
Comm 85.02	Scope.
Comm 85.10	Qualifications.
Comm 85.20	Soil evaluations.

Comm 85.30	Soil profile description and interpretations.
Comm 85.40	Evaluation reports.
Comm 85.50	Governmental unit review.
Comm 85.60	Soil saturation determinations.

**Note:** Chapter H 65 as it existed on May 31, 1983 was repealed and a new Chapter ILHR 85 was created effective June 1, 1983. Chapter ILHR 85 was renumbered Chapter Comm 85 under s. 13.93 (2m) (b) 1., Stats., and corrections made under s. 13.93 (2m) (b) 7., Stats., Register, February, 1997, No. 494. Chapter Comm 85 as it existed on June 30, 2000 was repealed and a new chapter Comm 85 was created, Register, April, 2000, No. 532, eff. 7-1-00.

**Comm 85.01 Purpose.** The purpose of this chapter is to establish the minimum requirements for evaluating and reporting soil and site characteristics that may affect treatment or dispersal of wastewater, treated wastewater, final effluent or nonwater-carried human wastes.

**History:** Cr. Register, April, 2000, No. 532, eff. 7-1-00.

**Comm 85.02 Scope.** Pursuant to s. 145.02, Stats., this chapter applies to all soil and site evaluations conducted relative to the treatment or dispersal of wastewater, treated wastewater, final effluent or nonwater-carried human wastes into soil.

**History:** Cr. Register, April, 2000, No. 532, eff. 7-1-00.

**Comm 85.10 Qualifications. (1) SOIL EVALUATION.** A soil evaluation for treatment or dispersal of wastewater, treated wastewater, final effluent or nonwater-carried human wastes regulated by chs. Comm 83 and 91 shall be performed by an individual who is a certified soil tester.

**Note:** Section Comm 5.33 delineates the qualifications and certification procedures for certified soil testers.

**(2) SITE EVALUATION.** A site evaluation, relative to the installation of a POWTS treatment, holding or dispersal component location, or to determine land slope or setback distances to topographic or other site features shall be performed by a Wisconsin registered architect, professional engineer, designer of plumbing systems, designer of private sewage systems or land surveyor; a certified soil tester or POWTS inspector; or a licensed master plumber or master plumber-restricted service.

**(3) SOIL SATURATION DETERMINATIONS.** Soil saturation determinations may only be conducted and reported by an individual who is a certified soil tester.

**History:** Cr. Register, April, 2000, No. 532, eff. 7-1-00.

**Comm 85.20 Soil evaluations. (1) GENERAL. (a)** Soil boring methods and procedures shall comply with this section.

**(b)** Maximum soil application rates shall be determined relative to the soil texture, structure and consistence for each soil horizon or layer.

**Note:** Section Comm 83.44 establishes maximum soil application rates and soil treatment capability for the design of POWTS treatment or dispersal components consisting in part of in situ soil.

**(2) NUMBER, TYPE AND DEPTH OF EVALUATIONS. (a) General.** The number, type, depth and location of soil profile evaluations shall be sufficient to delineate the area under investigation and to assure consistency of the data within that area.

**(b) Number and area. 1. a.** Except as provided in subd. 1. d. and subd. 2., a minimum of 3 soil profile evaluation excavations shall be used to delineate a site within which POWTS treatment or dispersal components consisting in part of in situ soil are to be located.

**b.** For estimated daily flows of 1,000 gallons per day or less, at least one soil profile evaluation excavation per treatment or dispersal site shall be constructed as a soil pit, and described in accordance with s. Comm 85.30 (1) (c).

**c.** For estimated daily flows greater than 1,000 gallons per day, at least 3 soil profile evaluations per treatment or dispersal site shall be constructed as soil pits, and described in accordance with s. Comm 85.30 (1) (c).

**d.** The department or governmental unit may require additional soil profile evaluation excavations to be constructed where soil variability considerations may not be adequately addressed. The department or governmental unit may specify that soil profile descriptions in accordance with s. Comm 85.30 (1) (c) be conducted for any additional soil profile evaluation excavations.

**2.** At least one soil pit or soil boring shall be used to establish soil suitability for a pit privy.

**Note:** Sections Comm 83.44 (3) and 91.12 (1) (b) 1. contain further information regarding privy siting and soil requirements.

**(c) Type. 1.** Soil profile evaluations used to determine soil application rates shall be conducted using soil pits.

**2.** Soil profile evaluations used to determine or identify soil horizon depths, soil color, soil texture, redoximorphic feature colors or depth to groundwater or bedrock shall be conducted using either soil pits or soil borings.

**(d) Depth.** Soil profile evaluations shall extend an adequate depth below the land surface to identify soil properties critical to soil treatment or dispersal of wastewater, treated wastewater, final effluent or nonwater-carried human waste.

**(3) EXCAVATION METHODS. (a) Soil profile excavations.** A soil profile excavation shall be of such size and construction to allow accurate determination of soil characteristics.

**(b) Soil borings. 1.** Soil borings shall be created by means of a soil bucket auger, soil probe, split-spoon sampler or Shelby tube having at least a 2 inch diameter.

**2.** A soil boring may not be created by means of a power auger.

**(c) Soil pits.** A soil pit shall be of adequate size, depth and construction to enable a person to safely enter and exit the pit and to complete a morphological soil profile description.

**Note:** Occupational safety and health administration regulations (29 CFR 1926, Subpart P) apply to certain types of excavations, and the persons entering such excavations need to be familiar with those regulations.

**(4) SOIL EVALUATION CONDITIONS. (a)** Soil color evaluations shall be performed on days when light conditions permit accurate color determinations.

**(b)** Frozen soil material shall be thawed prior to conducting evaluations for soil color, texture, structure and consistence.

**History:** Cr. Register, April, 2000, No. 532, eff. 7-1-00.

**Comm 85.30 Soil profile description and interpretations. (1) GENERAL. (a)** A soil profile description shall be prepared for each soil profile excavation constructed.

**(b)** Soil profile descriptions shall be written in accordance with the descriptive procedures, terminology and interpretations found

in Chapter 3 of the *Soil Survey Manual*, USDA, October, 1993, except where modified by, or in conflict with, this chapter.

(c) A soil profile description to substantiate soil application rates shall include at least all of the following morphological information for each soil horizon or layer:

1. Thickness in inches or decimal feet.
2. Munsell soil color notation.
3. Soil mottle or redoximorphic feature color, abundance, size and contrast.
4. United States Department of Agriculture, USDA, soil textural class with rock fragment modifiers.
5. Soil structure grade, size and shape.
6. Soil consistence.
7. Root abundance and size.
8. Soil boundary.
9. Occurrence of saturated soil, groundwater, bedrock or disturbed soil.

(d) A soil profile description to substantiate soil characteristics other than for application rates shall include the information specified in par. (c) 1. to 4. and 9.

**(2) SOIL INTERPRETATIONS.** (a) Redoximorphic features or mottles shall be interpreted as zones of seasonal or periodic soil saturation or groundwater, except as provided under sub. (3).

(b) Unless otherwise determined under s. Comm 85.60, the highest elevation of seasonal soil saturation shall be the ground surface where redoximorphic features are present within 4 inches of any of the following:

1. An A horizon that extends to the ground surface.
2. The lower boundary of overlying fill material where no buried A horizon exists.
3. An A horizon buried by overlying fill material.

**(3) SOIL COLOR PATTERN EXEMPTIONS.** (a) Without filing a report under s. Comm 85.60 (2), a certified soil tester may discount the following conditions, not limited by enumeration, as indicators of seasonally saturated soil:

1. Fossilized soil color patterns formed by historic periodic soil saturation.
2. A soil profile where redoximorphic features are confined within 12 inches of tension saturated silt loam or finer textured soil immediately overlying unsaturated coarse sandy loam or coarser textured soil that has a depth in the coarser material adequate to accommodate a distribution cell and dispersal zone.
3. A soil profile where redoximorphic features are confined within 24 inches of tension saturated silt loam or finer textured soil immediately overlying unsaturated coarse loamy sand or coarser textured soil that has a depth in the coarser material adequate to accommodate a distribution cell and dispersal zone.

4. Residual sandstone colors.
5. Unevenly weathered glacially deposited material, glacially deposited material naturally gray in color, or concretionary material in various stages of decomposition.
6. Deposits of lime.
7. Light colored silt or fine sand coatings on soil ped surfaces.

(b) Without filing a report under s. Comm 85.60 (2) for a specific site, the department may accept the results of soil saturation determinations or of the hydrograph procedure under s. Comm 85.60 previously conducted for areas adjacent to the site, provided that the soil profile descriptions and interpretations confirms that the soil and site conditions are similar for the specific site and the adjacent areas.

**(4) SOIL COLOR PATTERN REPORTS.** The certified soil tester shall report and describe any soil color pattern exemptions encountered.

**(5) DETERMINATION REQUESTS.** A certified soil tester may request a determination by the governmental unit or department staff on the significance of unusual soil color patterns as indicators of soil saturation that may not indicate saturated soil conditions that will interfere with wastewater treatment. The governmental unit or department may decline to make such determinations, and defer to the use of soil saturation determinations pursuant to s. Comm 85.60 or some other method to make a determination.

**History:** Cr. Register, April, 2000, No. 532, eff. 7-1-00; CR 02-129; r. and rec. (2) (b) and (3) (a) 2. and 3. Register January 2004 No. 577, eff. 2-1-04.

**Comm 85.40 Evaluation reports. (1) GENERAL.** A soil evaluation report shall be prepared and submitted to the governmental unit having jurisdiction upon the completion of the evaluation and associated report form.

**(2) SOIL REPORT CERTIFICATION AND FORMAT.** (a) *Soil evaluation reports.* Soil evaluation reports shall be prepared in a format specified by the department and this chapter.

**Note:** Soil evaluation report forms in an acceptable format are available from the Safety and Buildings Division, P.O. Box 7162, Madison, WI 53707-7162.

(b) *Certification.* 1. Except as provided in subd. 2., each page of a soil evaluation report shall bear:

- a. The original signature of the certified soil tester who collected the data;
- b. The certified soil tester's identification number; and
- c. The date the report is signed.

2. When more than one sheet of a soil evaluation report is bound together into one volume, only the title sheet shall:

- a. Be required to be signed, dated and bear the identification number of the certified soil tester who collected the data; and
- b. Clearly identify all other sheets comprising the bound volume.

**(3) REPORT CONTENTS.** (a) *Site report.* A site evaluation report shall include at least all of the following:

1. The site's legal description to within 40 acres.
2. The date the data was collected.
3. A legible and permanent site plan that complies with all of the following:
  - a. Is presented on paper no smaller than 8 1/2 inches by 11 inches in size.
  - b. Is drawn to scale or fully dimensioned.
  - c. Shows the extent of the site evaluated for soil dispersal or treatment.
4. Location information for all points under investigation including structures, property lines and other encumbrances to the treatment or dispersal component placement on the site.
5. Pertinent elevation data, such as:
  - a. A reference to, and description of, a permanent vertical and horizontal reference point or bench mark from which all distances and elevations are delineated on the site plan;
  - b. The natural, undisturbed surface grade elevation for all soil profile excavations;
  - c. The percent and direction of land slope for the site under evaluation;
  - d. Ground surface contour lines at an interval appropriate for the conditions present;
  - e. The floodplain elevation, if established, and current surface elevation of any adjacent navigable waters or reservoir; and
  - f. The existing grade adjacent to the groundwater elevation observation pipe, the top of the observation pipe, and the bottom of the observation pipe.

(b) *Soil report.* A soil evaluation report shall include at least all of the following:

1. A site evaluation report pursuant to par. (a).
2. The date soil evaluations were conducted.
3. The site's legal description to within 40 acres.

4. Soil profile descriptions pursuant to s. Comm 85.30 for all soil profile evaluation excavations.

**History:** Cr. Register, April, 2000, No. 532, eff. 7-1-00; CR 02-129: am. (3) (a) 3. (Intro) Register, January 2004 No. 577, eff. 2-1-04.

**Comm 85.50 Governmental unit review. (1) GENERAL.** (a) A governmental unit shall review all soil evaluation reports and site evaluation reports within 6 months of receipt.

(b) Upon completing the review of a soil evaluation report a governmental unit shall accept the report, reject the report, request additional information or clarification, or require verification under sub. (2).

(c) When a report is deemed acceptable, a governmental unit shall so indicate on the report and file the report for future reference.

(d) If the report is not acceptable, a governmental unit shall notify the submitter in writing and shall state the deficiencies or actions, or both, necessary to bring the report into compliance with this chapter or ch. Comm 83.

**(2) VERIFICATION.** (a) *Soil.* 1. The governmental unit or the department may require the property owner or the certified soil tester to provide soil pits in accordance with s. Comm 85.20 (3) for verification of soil profile evaluation data.

2. The certified soil tester who is responsible for the soil report shall be present at the site during the verification of soil profile evaluation data if so requested by the governmental unit or the department.

3. Soil verifications may not be conducted under adverse weather or light conditions that may lead to inaccurate results.

(b) *Site.* 1. The governmental unit or the department may require the property owner or certified individual who prepared the site report to provide assistance and equipment to verify site conditions.

2. The certified individual who is responsible for the site report shall be present at the site during the verification of site conditions if so requested by the governmental unit or department.

(c) *Report.* The governmental unit or the department shall complete a written report for each soil or site verification completed, and the results or findings of the report shall be filed with the soil and site evaluation report for future reference.

**History:** Cr. Register, April, 2000, No. 532, eff. 7-1-00.

**Comm 85.60 Soil saturation determinations.**

**(1) GENERAL.** (a) A property owner, or the owner's agent, may submit documentation to prove that redoximorphic features, or other soil color patterns, at a particular site are not indicative of periodically saturated soil conditions or high groundwater elevation.

(b) Documentation shall be in the form of an interpretive determination, soil saturation determination, hydrograph procedure or artificially controlled navigable water determination pursuant to this section.

**(2) INTERPRETIVE DETERMINATIONS.** (a) A written report by a certified soil tester evaluating and interpreting redoximorphic soil features, or other soil color patterns, may be submitted to the department in lieu of high groundwater determination data. The written report shall conclusively demonstrate that the existing soil morphological features or color patterns are not indicative of current conditions of periodic soil saturation.

(b) The department shall make a determination on the validity of the data, results and conclusions set forth in the report.

(c) The written report shall include, but is not limited to, all of the following information:

1. A soil evaluation report pursuant to s. Comm 85.40.
2. An interpretive review of the site including, but not limited to, all of the following:
  - a. Local hydrology.

- b. A historical interpretation of the local geomorphology.
- c. Soil disturbance and hydraulic modification.
- d. The landscape position and local topography in the area under investigation.

3. Soil series and mapping units, if available, for the immediate area, as listed in the USDA soil survey.

4. Data, if any, from previous soil saturation determinations in similar soil conditions and landscape position.

5. Any written reports, comments or recommendations by the governmental unit or department staff.

**(3) SOIL SATURATION DETERMINATION.** (a) *General.* Actual elevations of soil saturation may be determined at specific sites in accordance with the soil saturation determination procedures in par. (c).

(c) *Precipitation.* 1. Precipitation data reported for soil saturation determination purposes shall include monthly totals for September through May, and daily totals for February through May.

2. Precipitation data totals under subd. 1. shall be from either the closest local station to the site where the observation pipe is installed, or the average from the 3 closest local stations to the site. If averaging is used, the totals under subd. 1. shall be submitted for all 3 stations.

(d) *Regional water tables.* 1. Where sites are subject to a broad, relatively uniform, regional water table, the fluctuation observed over a several year cycle shall be considered.

2. At such sites, and where free water levels are more than 5 feet below grade, determinations shall be made using the hydrograph procedures contained in sub. (4).

3. Areas affected by a regional water table shall be delineated by the department in consultation with the affected counties and the Wisconsin Geological and Natural History Survey.

(e) *Fine textured soil.* 1. The department may prohibit soil saturation determinations in fine textured soil with high matric potentials where determination results may be inconclusive.

2. In such cases, the department may approve alternative methods to address the direct determination of saturated or near saturated soil conditions not enumerated in this section.

(f) *Groundwater elevation observation pipe installation and construction.* 1. Number of observation pipes. a. At least 3 groundwater elevation observation pipes shall be installed to delineate the area under investigation.

b. The governmental unit or department may require more than 3 observation pipes to adequately evaluate potential soil saturation conditions.

2. Observation pipe depth. a. At the request of the department or governmental unit, at least one observation pipe shall be constructed to a depth of 15 feet below the ground surface to determine if high groundwater elevation conditions are due to a perched water table and the possible extent of the saturated zone.

b. Other observation pipes shall terminate at specific depths below grade that will serve to evaluate where shallow perched zones of soil saturation occur within the soil profile.

c. The governmental unit or department may designate specific observation pipe depths and locations based on soil and site conditions, or experience in a particular geographic area or topographic position.

d. An observation pipe may not be less than 24 inches deep.

3. Observation pipe construction. The direct observation of soil saturation conditions shall be accomplished by means of observation pipes conforming to this subdivision and Figure 85.60-1.

a. The observation pipe shall be of a material meeting the standards in s. Comm 84.30 Table 84.30-1, except that lead pipe may not be used.

b. The inside diameter of an observation pipe may not be less than 2 inches or more than 4 inches nominal size.

- c. The borehole diameter shall be 2 to 4 inches larger than the outside diameter of the observation pipe.
- d. The top of the observation pipe shall terminate at least 18 inches above grade and be provided with a vented cap.
- e. The bottom of the observation pipe shall terminate with a slotted, or screened pipe. The slots or screen shall extend 6 to 18 inches above the bottom of the pipe and be at least 4 inches below the filter pack seal. The slots or screen shall not be hand cut and shall be designed to retain soil particles with a diameter of greater than 0.02 inch.
- f. Except for the vented end cap, joints between lengths of pipe and fittings shall conform to s. Comm 84.40.
- g. Finished grade around the observation pipe shall be sloped

- away from the observation pipe using soil material.
- h. At a minimum, the upper 12 inches of annular space surrounding the observation pipe shall be sealed by puddled clay, bentonite, or an equal-parts mixture of soil, bentonite and cement. A surface seal may not be necessary if the entire soil profile is sand.
- i. The annular space seal below 12 inches and to the top of the filter pack seal may be of unspecified soil material.
- j. A filter pack seal shall be installed above the filter pack to prevent soil migration downward into the filter pack.
- k. The observation pipe shall be set on at least 2 inches of pea gravel that extends 4 to 6 inches above the top of the screen or highest slot. The gravel filter pack is not necessary if the natural soil is coarse sand or coarser.

**Groundwater Elevation Observation Pipe**

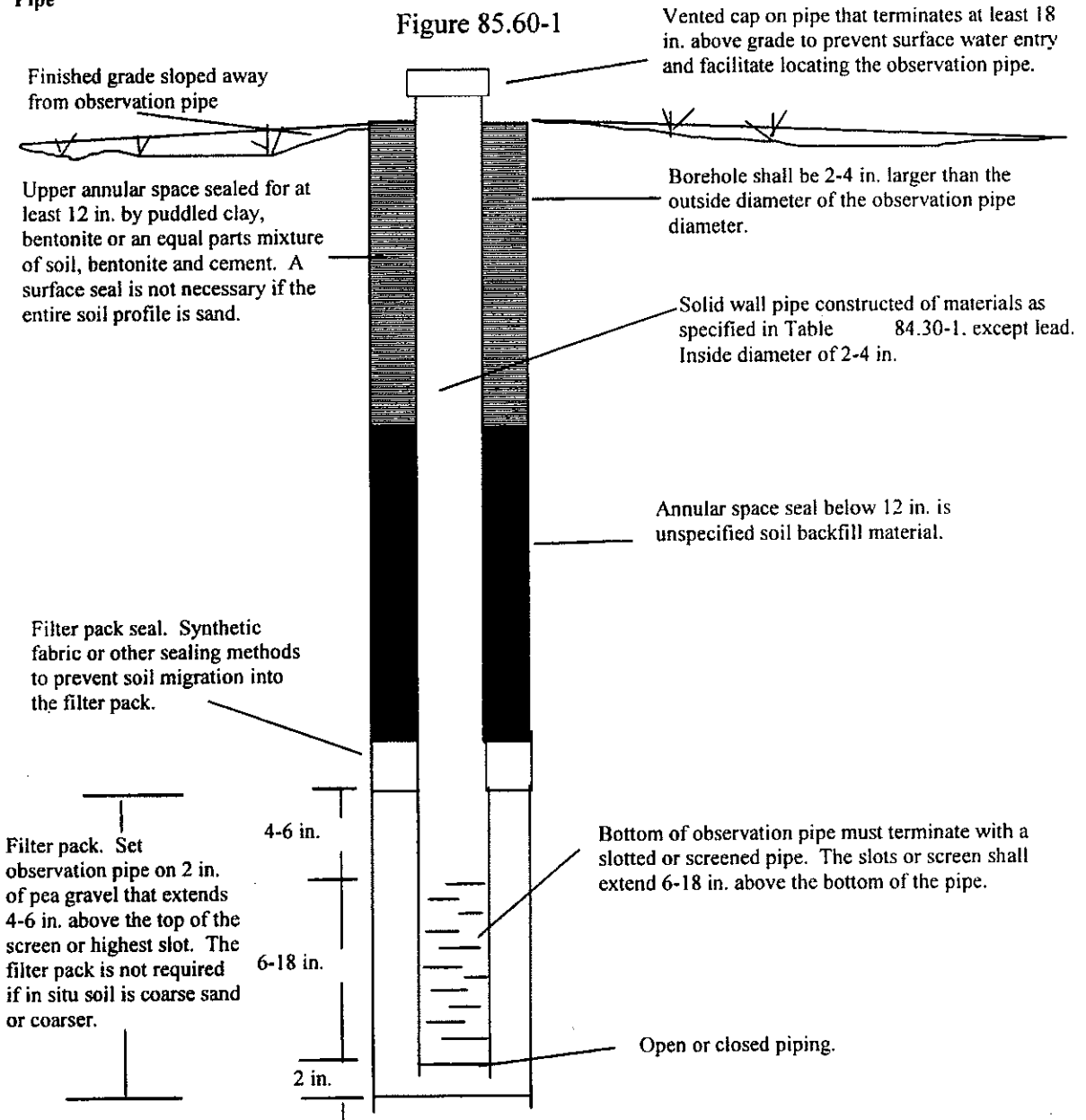

(g) *Observations.* 1. Observation period. The observation period for soil saturation determinations shall begin on or before the appropriate date specified in Figure 85.60-2, and end June 1<sup>st</sup>.

2. Alternate observation period. The department may approve an alternate observation period if the data presented conclusively demonstrates equivalency to conditions encountered during a normal spring observation period.

3. Minimum frequency. Observations shall be made on the first day of the observation period and at least every 7 days thereafter until the observation period is complete.

(h) *Conclusions.* 1. The highest level of soil saturation shall be considered the highest level of free water observed in an observation pipe on 2 occasions 7 days apart during the observation period.

2. The results of soil saturation determinations under this section shall be considered inconclusive if the precipitation totals under par. (c) do not equal or exceed:

a. 8.5 inches from September 1<sup>st</sup> through the last day of February; and

b. 7.6 inches from March 1<sup>st</sup> through May 31<sup>st</sup>.

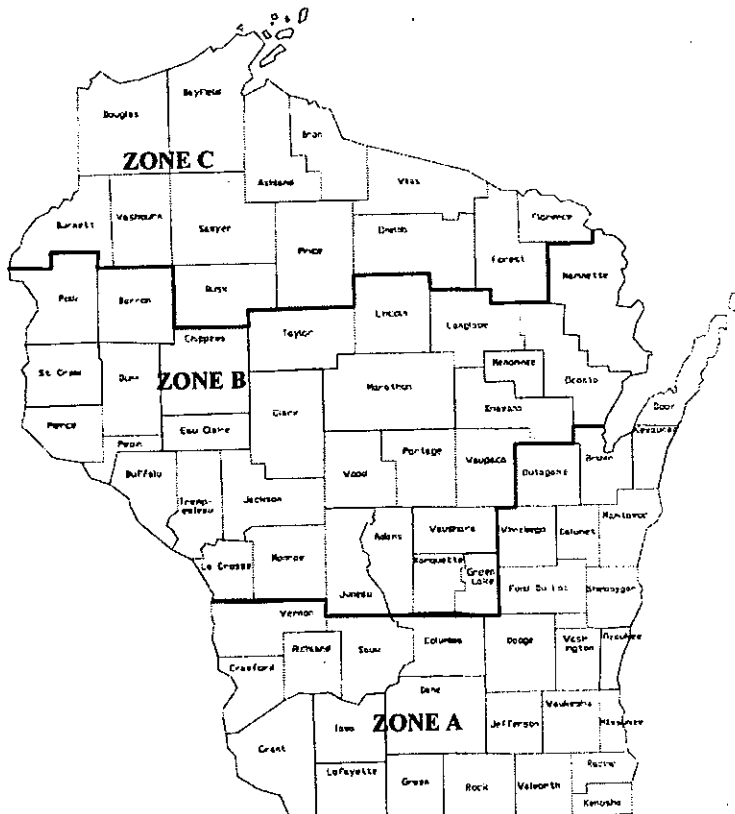

**Figure 85.60-2**  
**Latest Date to Begin Spring Soil Saturation Monitoring**

Zone A	February 15
Zone B	March 1
Zone C	March 15

(i) *Reporting data.* 1. Within 180 days of the completion of the observations, 3 copies of the following data shall be submitted to the department for review:

- a. A soil and site evaluation report pursuant to s. Comm 85.40.
- b. Observation pipe installation, depth, location and elevation information.
- c. Precipitation data and name of any local station used.
- d. Observation dates.
- e. Current and any prior observation results.

f. Any governmental unit observations or reports pertaining to the soil saturation determination observations, observation pipe construction or soil/site conditions.

2. Within 180 days of the completion of the observations, one copy of the data specified in subd. 1. shall be filed with the governmental unit having jurisdiction.

(j) *Report forms.* Soil saturation determination results shall be reported on forms specified by the department.

**Note:** Soil saturation determination report forms in an acceptable format are available from the Safety and Buildings Division, P.O. Box 7162, Madison, WI 53707-7162.

(k) *Failure to report.* Failure to file soil saturation determination results with the governmental unit and department within 60 days may disqualify the site from future soil saturation or interpretive determinations.

**(4) HYDROGRAPH PROCEDURE.** (a) 1. Except as provided in subd. 3., where regional water table fluctuations are considered in deep sandy soil, the predicted high groundwater elevation shall be established using hydrograph documentation.

2. Except as provided in subd. 3., the highest groundwater elevation shall be determined by direct observation during the soil profile evaluation or by one of the hydrograph methods outlined in pars. (b) to (d), whichever is highest.

3. The department or governmental unit may accept use of the hydrograph procedure to predict regional water table levels on sites where inclusions of sandy loam or finer soil material, or massive conditions exist.

(b) 1. If there is less than 5 feet to free water below original grade, the procedures detailed in sub. (2) or (3) shall be used to determine the highest predicted groundwater elevation at the site.

2. If there is 5 feet or more to free water below original grade, the hydrograph procedure may be used to determine the highest predicted groundwater elevation at the site.

(c) When free water at the site is 5 to 10 feet below grade, all of the following procedures apply:

1. A completed soil and site evaluation report pursuant to s. Comm 85.40 that confirms the elevation of free water, if observed, shall be prepared.

2. A slotted or screened groundwater elevation observation pipe shall be installed at the proposed system location to a depth of at least 12 inches below the free water elevation.

b. The observation pipe shall be installed pursuant to sub. (3) (f) 3.

3. a. The water level in the observation pipe shall be recorded after completion of the observation pipe installation and 7 days later.

b. The highest of the 2 water levels shall be used to complete the hydrograph procedure.

4. The permanent USGS groundwater elevation well or wells as assigned by the governmental unit or department shall be read within 24 hours of establishing the actual free water elevation at the site.

5. The hydrograph procedure shall be completed and the results shall be reported to the governmental unit in a format specified by the department.

**Note:** Soil evaluation report forms in an acceptable format are available from the Safety and Buildings Division, P.O. Box 7162, Madison, WI 53707-7162.

(d) When free water at the site is more than 10 feet below grade, all of the following procedures apply:

1. A completed soil and site evaluation report pursuant to s. Comm 85.40 that confirms the elevation of free water, if observed, shall be prepared.

2. The permanent USGS groundwater elevation well or wells assigned to the project by the governmental unit or department

shall be read within 24 hours of the actual free water determination at the site.

3. The hydrograph procedure shall be completed and the results shall be reported to the governmental unit in a format specified by the department.

**Note:** Hydrograph soil saturation report forms in an acceptable format are available from the Safety and Buildings Division, P.O. Box 7162, Madison, WI 53707-7162.

(e) The governmental unit or the department may request more than one USGS groundwater well or other wells assigned by the governmental unit or the department be used to complete the hydrograph procedure.

(f) The governmental unit or the department may reject or suspend use of the hydrograph procedure when erratic groundwater tables are present due to recent, significant recharge events.

**(5) ARTIFICIALLY CONTROLLED NAVIGABLE WATERS DETERMINATION.** (a) If the groundwater elevation at a site is influenced by the artificial control of navigable waters by a recognized management entity, all of the following conditions shall be addressed:

1. If loamy sand or coarser soil textures prevail at a site, the groundwater elevation at the site shall be compared to the current and highest controlled navigable water elevation.

2. The highest normal groundwater elevation at such sites shall be the higher of either the observed elevation or an adjusted elevation based on the controlled water.

(b) An artificially controlled navigable waters determination report shall be prepared and submitted to the governmental unit having jurisdiction upon the completion of the determination and associated report.

**(6) SOIL SATURATION OBSERVATION PIPE REMOVAL.** The following requirements shall apply to all groundwater elevation observation pipes installed pursuant to this section:

(a) *Removal timeline.* Unless specifically approved by the governmental unit or department, all groundwater elevation observation pipes shall be removed within 60 days after the completion of soil saturation determination.

(b) *Contamination conduit.* Any groundwater elevation observation pipe found by the department or governmental unit to be acting as a conduit for groundwater contamination shall be ordered removed immediately.

**(7) VERIFICATION.** (a) *Verification.* 1. The governmental unit or department may request verification of soil saturation determinations pursuant to s. Comm 85.50 (2), and proper observation pipe installation pursuant to this section.

2. The governmental unit or the department may require any groundwater elevation observation pipe deemed by the governmental unit or the department to be in poor contact with the surrounding soil to be reinstalled pursuant to this section.

(b) *On-site visits.* 1. The governmental unit or department may visit sites during soil saturation determination periods or at other reasonable times to determine the accuracy of data.

2. A written record of on-site visits in subd. 1. shall be maintained by the agency conducting the visits.

**History:** Cr. Register, April, 2000, No. 532, eff. 7-1-00; CR 02-129: r. and recr. (1) and (3) (h) 1., am. (2) (c) (intro.), (2) (c) 2. b., (3) (i) 1. (intro.) and 2., (4) (a) 1. and 2., (4) (c) (intro.), 2. b., 5., (d) (intro.) and 3., r. (3) (b), cr. (4) (a) 3., (4) (e) and (f), and (5), renum. (5) and (6) to be (6) and (7) Register, January 2004 No. 577, eff. 2-1-04; corrections in (3) (a) and (h) made under s. 13.93 (2m) (b) 7., Stats., Register, January 2004 No. 577.