

## Chapter Comm 21 CONSTRUCTION STANDARDS

**Subchapter I — Scope**

Comm 21.01 Scope.

**Subchapter II — Design Criteria**

- Comm 21.02 Loads and materials.
- Comm 21.03 Exits.
- Comm 21.035 Interior circulation.
- Comm 21.04 Stairways and elevated areas.
- Comm 21.042 Ladders.
- Comm 21.045 Ramps.
- Comm 21.05 Natural light and natural ventilation.
- Comm 21.06 Ceiling height.
- Comm 21.07 Attic and crawl space access.
- Comm 21.08 Fire separation and dwelling unit separation.
- Comm 21.085 Fireblocking.
- Comm 21.09 Smoke detectors.
- Comm 21.095 Automatic fire sprinklers.
- Comm 21.097 Carbon monoxide alarms.
- Comm 21.10 Protection against decay and termites.
- Comm 21.11 Foam plastic.
- Comm 21.115 Installation of elevators or dumbwaiters.

**Subchapter III — Excavations**

- Comm 21.12 Grade.
- Comm 21.125 Erosion control and sediment control.
- Comm 21.126 Storm water management.
- Comm 21.13 Excavations adjacent to adjoining property.
- Comm 21.14 Excavations for footings and foundations.

**Subchapter IV — Footings**

- Comm 21.15 Footings.
- Comm 21.16 Frost protection.

Comm 21.17 Drain tiles.

**Subchapter V — Foundations**

Comm 21.18 Foundations.

**Subchapter VI — Floors**

- Comm 21.19 Floor design.
- Comm 21.20 Concrete floors.
- Comm 21.203 Garage floors.
- Comm 21.205 Wood floors in contact with the ground.
- Comm 21.21 Precast concrete floors.
- Comm 21.22 Wood frame floors.
- Comm 21.225 Decks.

**Subchapter VII — Walls**

- Comm 21.23 Wall design.
- Comm 21.24 Exterior covering.
- Comm 21.25 Wood frame walls.
- Comm 21.26 Masonry walls.

**Subchapter VIII — Roof and Ceilings**

- Comm 21.27 Roof design and framing.
- Comm 21.28 Weather protection for roofs.

**Subchapter IX — Fireplace Requirements**

- Comm 21.29 Masonry fireplaces.
- Comm 21.30 Masonry chimneys.
- Comm 21.32 Factory-built fireplaces.

**Subchapter X — Construction in Floodplains**

- Comm 21.33 Construction in floodplains.
- Comm 21.34 Construction in coastal floodplains.

**Subchapter XI — Installation of Manufactured Homes**

Comm 21.40 Installation standards.

Note: Chapter Ind 21 was renumbered to be chapter ILHR 21, Register, February, 1985, No. 350, eff. 3-1-85. Chapter ILHR 21 was renumbered chapter Comm 21 under s. 13.93 (2m) (b) 1., Stats., and corrections made under s. 13.93 (2m) (b) 6. and 7., Stats., Register, January, 1999, No. 517. Chapter Comm 21 was reprinted to correct the Table of Contents, Register October 2009 No. 646.

**Subchapter I — Scope**

**Comm 21.01 Scope.** The provisions of this chapter shall apply to the design and construction of all one- and 2-family dwellings.

History: Cr. Register, November, 1979, No. 287, eff. 6-1-80.

**Subchapter II — Design Criteria**

**Comm 21.02 Loads and materials.** Every dwelling shall be designed and constructed in accordance with the requirements of this section.

(1) **DESIGN LOAD.** Every dwelling shall be designed and constructed to support the actual dead load, live loads and wind loads acting upon it without exceeding the allowable stresses of the material. The construction of buildings and structures shall result in a system that provides a complete load path capable of transferring all loads from point of origin through the load-resisting elements to the foundation.

(a) **Dead loads.** Every dwelling shall be designed and constructed to support the actual weight of all components and materials. Earth-sheltered dwellings shall be designed and constructed to support the actual weight of all soil loads.

(b) **Live loads.** 1. Floors and ceilings. Floors and ceilings shall be designed and constructed to support the minimum live loads listed in Table 21.02. The design load shall be applied uniformly over the component area.

**TABLE 21.02**

Component	Live Load (pounds per sq. ft.)
Floors . . . . .	40
Garage floors . . . . .	50
Exterior balconies, decks, porches . .	40
Ceilings (with storage) . . . . .	20
Ceilings (without storage) . . . . .	5

2. Snow loads. Roofs shall be designed and constructed to support the minimum snow loads listed on the zone map. The loads shall be assumed to act vertically over the roof area projected upon a horizontal plane.

(c) **Wind loads.** Dwellings shall be designed and constructed to withstand a horizontal and uplift pressure of 20 pounds per square foot acting over the surface area.

(d) **Fasteners.** All building components shall be fastened to withstand the dead load, live load and wind load.

Note: See the Appendix for a schedule of fasteners that will be acceptable to the department for compliance with this subsection. Other fastening methods may be allowed if engineered under s. Comm 21.02 (3).

(2) METHODS OF DESIGN. All dwellings shall be designed by the method of structural analysis or the method of accepted practice specified in each part of this code.

Note: See ch. NR 116, rules of the department of natural resources, for special requirements relating to buildings located in flood plain zones. Information regarding the elevation of the regional flood may be obtained from the local zoning official.

(3) STRUCTURAL STANDARDS. (a) General. Design, construction, installation, practice and structural analysis shall conform to

the following nationally recognized standards.

(b) Wood. 1. Except as provided in subd. 1. a. and b., structural lumber, glue-laminated timber, timber pilings and fastenings shall be designed in accordance with the "National Design Specification for Wood Construction" and the "Design Values for Wood Construction," a supplement to the National Design Specification for Wood Construction.

Figure 21.02  
ZONE MAP FOR ROOF LOADS

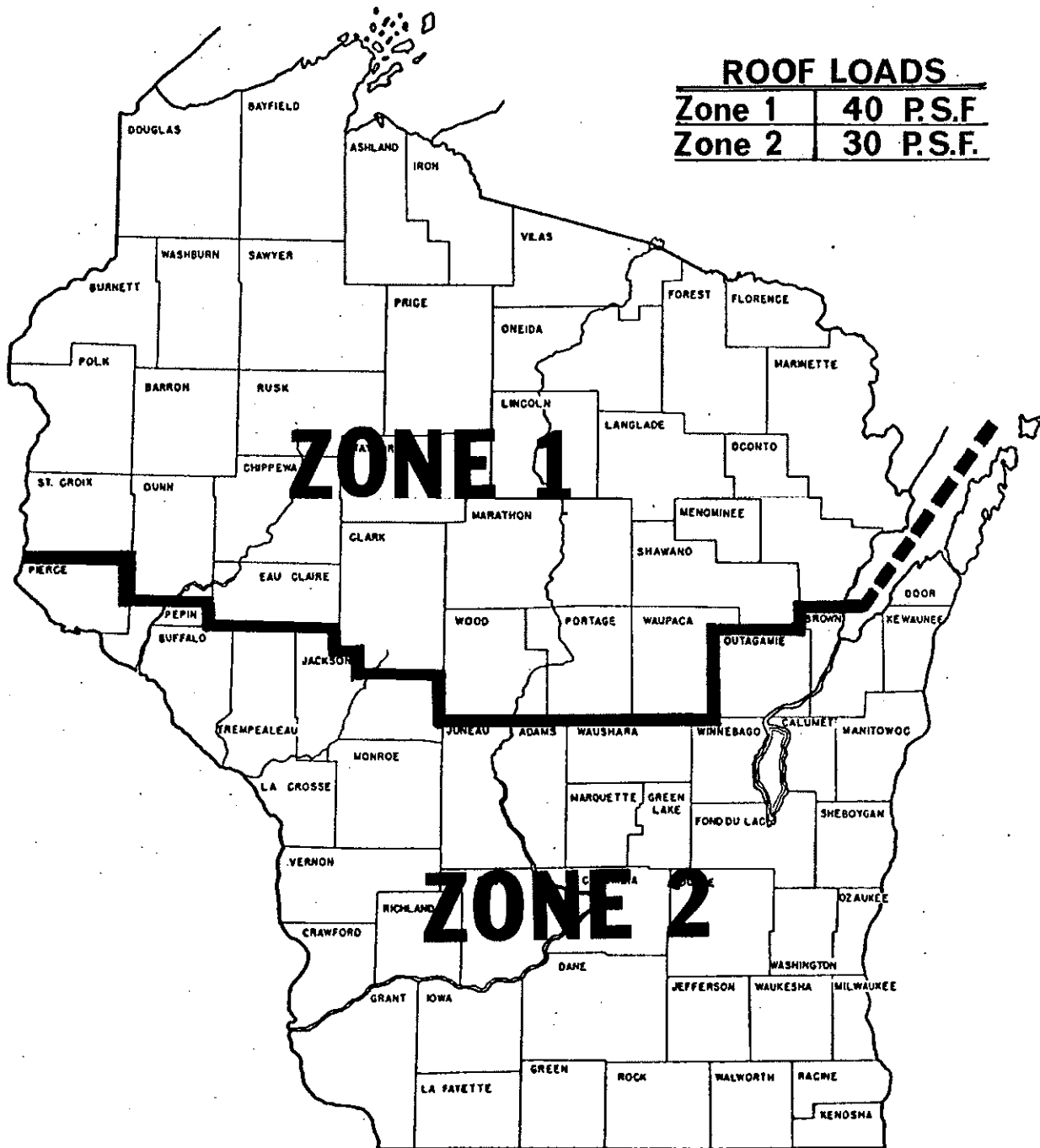

a. Section 2.2.5.3. The cumulative effects of short-time loads, such as snow, shall be considered in determining duration of load. For snow load, no greater duration of load factor than 1.15 shall be used.

b. Section 4.1.7. The provisions of this section shall also apply to reused lumber. Reused lumber shall be considered to have a duration of load factor of 0.90.

2. Span tables for joists and rafters printed in the appendix or approved by the department may be used in lieu of designing by structural analysis.

3. Sawn lumber that is not graded in accordance with the standards under subd. 1., shall use the NDS published allowable design stresses for the lumber species using grade number 3 when used for studs, stringers, rafters or joists and may use grade number 1 when used for beams, posts or timbers.

(c) *Structural steel.* The design, fabrication and erection of structural steel for buildings shall conform to Specification for Structural Steel Buildings, Allowable Stress Design and Plastic Design and the provisions of the accompanying commentary as adopted under Table 20.24-3.

(d) *Concrete.* Plain, reinforced or prestressed concrete construction shall conform to the following standards:

1. ACI Standard 318, "Building Code Requirements for Reinforced Concrete".

2. ACI Standard 318.1, "Building Code Requirements for Structural Plain Concrete".

(e) *Masonry.* The design and construction of masonry shall conform to the following standards:

1. ACI 530, Building Code Requirements for Masonry Structures.

2. ACI 530.1, Specification for Masonry Structures.

(f) *Engineered structural components.* Engineered structural components shall be used in accordance with structural analysis or with load tables supplied by the manufacturer, provided those load tables were developed using structural analysis or load testing.

(g) *Whole logs.* Dwellings constructed of whole logs shall conform to the following standards:

1. ILBA Log Building Standards for Residential, Handcrafted, Interlocking, Scribe-fit Construction.

Note: This standard requires the minimum log diameter to be 8 inches.

2. ICC/ANSI 400, Standard on the Design and Construction of Log Structures.

**History:** Cr. Register, November, 1979, No. 287, eff. 6-1-80; r. and recr. (3) (a), am. (3) (c) and Table 21.02, cr. (3) (c) 2., Register, February, 1985, No. 350, eff. 3-1-85; cr. (3) (a) 3., am. (3) (b), renum. (3) (e) to be (3) (d), and am., Register, November, 1995, No. 479, eff. 12-1-95; renum. and am. (1) (c) to be (1) (c) 1., cr. (1) (c) 2. and 3., am. (3) (d), Register, January, 1999, No. 517, eff. 2-1-99; r. (3) (a) 3. and cr. (3) (e), Register, March, 2001, No. 543, eff. 4-1-01; correction in (3) (b) made under s. 13.93 (2m) (b) 7., Stats., Register, March, 2001, No. 543; CR 02-077: am. (1) (intro.) and (d) Register May 2003 No. 569, eff. 8-1-03; corrections in (3) (b) and (d) made under s. 13.93 (2m) (b) 7., Stats., Register May 2003 No. 569; CR 08-043: r. (1) (c) 2. and 3., renum. (1) (c) 1., (3) (a) to (e) and (intro.) to be (1) (c), (3) (b) to (f) and (3) (a) and am. (3) (a) and (c), am. (3) (title), cr. (3) (b) 3., (e) 1., 2. and (g), am. (3) (e) Register March 2009 No. 639, eff. 4-1-09.

**Comm 21.03 Exits.** Exits, doors and hallways shall be constructed as specified in this section.

(1) **EXITS FROM THE FIRST FLOOR.** (a) Except as allowed under par. (h), every dwelling unit shall be provided with at least 2 exit doors accessible from the first floor.

(b) At least one of the exits shall discharge to grade and may not go through a garage. This exit may include interior or exterior stairs.

(c) An additional exit may discharge to an outside balcony that complies with sub. (8).

(d) An additional exit may discharge into an attached garage provided the garage has an exit door that discharges to grade. An overhead garage door may not be used as an exit door.

(e) Except as allowed under pars. (f) and (h), the 2 required exit doors shall be separated by at least the greater of the following distances:

1. One-third the length of the longest diagonal of the floor in plan view, exclusive of an attached garage.

2. 20 feet.

Note: See appendix for examples of exit separation design.

(f) 1. First floor levels that do not meet the separation requirements under par. (e), shall have at least one egress window complying with sub. (6) on that floor level.

2. An egress window to comply with subd. 1. shall be separated from at least one door on the first floor by one of the distances under par. (e).

3. If first floor levels that do not meet the separation requirements under par. (e) contain one or more sleeping rooms, each sleeping room shall have at least one egress window complying with sub. (6).

(g) 1. The exit separation distance required under par. (e) shall be calculated or measured as a straight line from the midpoint of one doorway to the midpoint of the other doorway.

2. For exiting through an attached garage, the separation distance shall be measured using the door connecting the garage and the dwelling. Distance within the garage shall be ignored.

(h) 1. Dwellings consisting of no more than a first floor with a maximum floor area of 400 square feet and a loft area not exceeding half of the first floor area, shall be provided with at least one exit door leading directly to the exterior and at least one egress window that complies with sub. (6).

2. a. Dwellings that meet the size restrictions under subd. 1., are not required to meet the exit separation requirements under par. (e) or (f).

b. If a dwelling that meets the size restrictions under subd. 1., has more than one room on the first floor, the door and the egress window shall be located in different rooms.

(2) **EXITS FROM THE SECOND FLOOR.** (a) At least 2 exits shall be provided from the second floor. One of the exits shall be a stairway or ramp and lead to the first floor or discharge to grade. The second exit may be via a stairway or ramp which discharges to grade or may discharge to a balcony which complies with sub. (8).

(b) Except as provided in par. (c), windows which comply with sub. (6) may be provided in each second floor bedroom in lieu of the second exit from the floor.

(c) Where the second floor is the lowest floor level in a dwelling unit, as in an up-and-down duplex, windows may not be provided as the second exit from the floor.

(3) **EXITS ABOVE THE SECOND FLOOR.** (a) Except as provided under pars. (b) and (c), each habitable floor above the second floor shall be provided with at least 2 exits that meet all of the following requirements:

1. The exits shall be stairways or ramps that lead to the second floor or discharge to grade.

2. The exits shall be located such that an exit is accessible to the second floor if another exit is blocked.

(b) A second stairway or ramp exit is not required for habitable areas on a third floor that meet all of the following requirements:

1. The habitable area consists of a single room.

Note: Non-habitable areas, such as closets and bathrooms may be partitioned off.

2. The room is not used for sleeping.

3. The habitable area has a floor area of 400 square feet or less.

4. There is at least one egress window meeting the requirements of sub. (6) in the habitable area.

(c) A second stairway or ramp exit is not required for habitable areas on a third floor that meet all of the following requirements:

1. The dwelling is fully sprinklered in accordance with NFPA 13R or NFPA 13D.

2. If a required exit includes an attached garage, the garage shall be sprinklered.

(4) **EXITS FROM LOFTS.** (a) At least one stairway exit shall be provided, to the floor below, for a loft exceeding 400 square feet in area.

(b) At least one stairway or ladder exit shall be provided to the floor below for a loft, 400 square feet or less, in area.

(5) EXITS FROM BASEMENTS AND GROUND FLOORS. (a) *General*. Except as provided in par. (b), all basements and ground floors shall be provided with at least one exit of the following types:

1. A door to the exterior of the dwelling.
2. A stairway or ramp that leads to the floor above.

(b) *Basements and ground floors used for sleeping*. 1. Basements and ground floors used for sleeping shall be provided with at least 2 exits.

2. The exits shall be located as far apart as practical.
3. The exits may not be accessed from the same ramp or stairway.
4. In addition to the exit type required under par. (a), the second exit from a basement or ground floor used for sleeping shall be one of the following types:

- a. A door to the exterior of the dwelling.
- b. A stairway or ramp that leads to the floor above.
- c. A stairway that leads to a garage provided the garage has an exit door other than the overhead door.
- d. An egress window that complies with sub. (6), located in each bedroom.

(6) WINDOWS USED FOR EXITING. Windows which are installed for exit purposes shall comply with the requirements of this subsection.

(a) The window shall be openable from the inside without the use of tools or the removal of a sash. If equipped with a storm or screen, it shall be openable from the inside.

(b) 1. The nominal size of the net clear window opening shall be at least 20 inches by 24 inches irrespective of height or width. Nominal dimensions shall be determined by rounding up fractions of inches if they are 1/2-inch or greater or rounding down fractions of inches if they are less than 1/2-inch.

2. No portion of the window, including stops, stools, meeting rails and operator arms, shall infringe on the required opening.

(c) The area and dimension requirements of par. (b) may be infringed on by a storm window.

(d) 1. For any window used for exiting, the lowest point of clear opening shall be no more than 60 inches above the floor.

2. If the lowest point of clear opening is more than 46 inches above the floor, a permanent platform or fixture shall be installed such that a flat surface at least 20 inches wide and 9 inches deep is located no more than 46 inches directly below the clear opening.

3. The topmost surface of the platform or fixture shall be no more than 24 inches above the floor.

4. The topmost surface of the platform or fixture shall support a live load of at least 200 pounds.

5. A Step used for the sole purpose of reaching the top of the platform or fixture is exempt from the requirements of s. Comm 21.04.

(e) 1. An egress window with any point of clear opening below adjacent grade shall be provided with an areaway in accordance with this section.

2. The width of the areaway shall be at least equal to the width of the window.

3. The areaway shall be a minimum of 36 inches measured perpendicular from the outer surface of the below-grade wall.

4. If the bottom of the areaway is more than 46 inches below adjacent grade or the top of the areaway enclosure, the areaway shall be provided with a ladder or at least one additional step to aid egress. Steps used to comply with this section are exempt from the requirements of s. Comm 21.04.

5. a. Ladders or other steps used to comply with subd. 4. may infringe on the required area of the areaway by a maximum of 6 inches.

b. Ladder rungs shall have a minimum inside width of at least 12 inches and shall project at least 3 inches from the wall behind the ladder.

c. Ladder rungs shall be able to support a concentrated load of 200 pounds.

d. Ladder rungs shall have a maximum rise of 12 inches between rungs and shall extend to within 12 inches of exterior grade.

6. The areaway shall be constructed such that water entering the areaway does not enter the dwelling.

(7) DOORS USED FOR EXITING. (a) Doors used for exiting from a dwelling shall meet the following dimensions:

1. At least one exit door shall be a swing-type door at least 80 inches high by 36 inches wide.

2. Except as allowed under subds. 3. and 4., other required exit doors shall be at least 76 inches high by 32 inches wide.

3. Where double doors are used as a required exit, each door leaf shall provide a clear opening at least 30 inches wide and be at least 76 inches high.

4. Where sliding doors are used as a required exit, the clear opening shall be at least 30 inches wide and be at least 76 inches high.

(b) All exit doors shall be openable from the interior without the use of a key.

(8) BALCONIES. (a) Balconies shall be made of concrete, metal or wood which is treated, protected or naturally decay-resistant in accordance with s. Comm 21.10.

(b) Balconies shall be provided with guardrails in accordance with s. Comm 21.04 (3).

(c) Balconies which are required for exit purposes shall also comply with all of the following requirements:

1. The balcony guardrail shall terminate no more than 46 inches above the floor level of the balcony.

2. The floor level of the balcony shall be no more than 15 feet above the grade below.

3. The floor of the balcony shall have minimum dimensions of 3 feet by 3 feet. The guardrail and its supports may infringe on the dimensions of the required area.

(9) SPLIT LEVEL DWELLINGS. In determining the exit requirement in a split level dwelling, all levels that are to be considered a single story shall be within 5 feet of each other.

(10) TWO-FAMILY DWELLINGS. In a 2-family dwelling, each dwelling unit shall be provided with exits in compliance with this section.

*History:* Cr. Register, November, 1979, No. 287, eff. 6-1-80; r. and recr. Register, February, 1985, No. 350, eff. 3-1-85; emerg. am. (1) (b), (2) and (5) (b) 2., eff. 5-7-85; r. (1) (b), renum. (1) (a) to be (1), am. (2), (7) and (8), r. and recr. (5) to (6), cr. (6m) and (10) to (12), Register, January, 1989, No. 397, eff. 2-1-89; am. (3) and (7), r. and recr. (10) and (11), Register, March, 1992, No. 435, eff. 4-1-92; am. (8), r. and recr. (10) (a), Register, November, 1995, No. 479, eff. 12-1-95; am. (6m) (b) 1. and 2., r. (6m) (b) 3., Register, January, 1999, No. 517, eff. 2-1-99; r. and recr. (1), (5), (7) and (8), am. (2) (b), r. (6), renum. (6m) to be (6) and r. and recr. (d) and (e) as renum., Register, March, 2001, No. 543, eff. 4-1-01; reprinted to correct printing error in (6) (e) 2., Register September 2001 No. 549; CR 02-077: am. (1) (a), (5) (a) (intro.) and (10) (b), r. and recr. (1) (e), cr. (1) (f) to (h), Register May 2003 No. 569, eff. 8-1-03; CR 03-097: am. (1) (h) 1., Register November 2004 No. 587, eff. 1-1-05; CR 08-043: am. (title) and (1) (b), r. and recr. (3) and (7), renum. (6) (e) 5. and (10) to (12) to be (6) (c) 5. a. and (8) to (10), cr. (6) (c) 5. b. to d., r. (8) and (9) Register March 2009 No. 639, eff. 4-1-09; correction in (2) (a) made under s. 13.92 (4) (b) 7., Stats., Register March 2009 No. 639; CR 09-104: am. (1) (c) Register December 2010 No. 660, eff. 1-1-11.

**Comm 21.035 Interior circulation.** (1) DOORS AND OPENINGS. All doors and openings to the following areas shall be at least 80 inches high and provide either a net clear opening width of 30 inches or be a 32-inch door:

(a) Except as provided under pars. (b) and (c), all entrances into common use areas.

(b) At least 50% of the bedrooms.

(c) 1. At least one full bathroom, including doors or openings to a sink, toilet and tub or shower. If this bathroom is accessible only through a bedroom, the bedroom door shall meet the minimum width requirements of this section.

2. If one or more full bathrooms are provided on the first floor, the bathroom meeting the requirements under this section shall be on the first floor.

*Note:* This section does not require a full bathroom on the first floor.

(2) HALLWAYS. (a) Except as allowed under par. (b), the clear width of hallways shall be at least 36 inches.

(b) The following are allowed to infringe on the required clear width of a hallway:

1. Door hardware and finish trim.
2. Handrails may infringe into the minimum width of a hallway up to 4½ inches on each side.
3. Heating registers may infringe into the minimum width of a hallway up to 4½ inches and no part of the register may be more than 38 inches above the floor.
4. Ducts, pipes, light fixtures, structural features, and corner treatments that are within 84 inches of the floor may infringe into the minimum width of a hallway by a maximum of 4½ inches on each side.
5. Unlimited infringements are allowed in a hallway more than 84 inches above the floor.

(3) **KITCHENS.** (a) There shall be at least 30 inches of clearance between a wall, a permanently-installed kitchen island, permanently-installed kitchen cabinets and the following kitchen appliances, if provided:

1. A range, cook top or oven.
2. A sink, refrigerator or freezer.

(b) Measurements shall be taken from the face of the wall, island, cabinet or appliance, ignoring knobs and handles.

**Note:** See ICC/ANSI A117.1 chapter 10 for more guidelines relating to doors and accessible routes. Under that standard, doors must be at least 80-inches in height and provide a minimum net clear opening of 31¼-inches in width in order to provide accessibility for people with disabilities.

**History:** CR 08-043; cr. Register March 2009 No. 639, eff. 4-1-09.

#### Comm 21.04 Stairways and elevated areas.

(1) **SCOPE.** (a) *General.* Except as provided under par. (b), the following stairways shall conform to the requirements of this section.

1. Every interior and exterior stairway attached to, or supported by any part of the structure covered under this code.
2. Tub access steps, unless they are an integral part of an approved plumbing product.

(b) *Exceptions.* The following stairways are not required to comply with the requirements of this section:

1. Stairways leading to non-habitable attics or crawl spaces.
2. Non-required stairways connecting the basement directly to the exterior of the structure without communicating with any other part of the structure.

(2) **DETAILS.** (a) *Width.* 1. Except for spiral staircases under subd. 2., stairways shall measure at least 36 inches in width. Handrails and associated trim may project a maximum of 4.5 inches into the required width at each side of the stairway.

2. Spiral staircases shall be at least 26 inches wide measured from the outer edge of the supporting column to the inner edge of the handrail.

(b) *Riser height.* 1. a. Except for spiral staircases under subd. 2., risers may not exceed 8 inches in height measured vertically from tread to tread.

b. At the top and bottom of a flight, measurement shall be taken from the top of the nosing to the finished floor surface unless the finished surface is carpeting, in which case measurement shall be made to the hard surface below the carpeting.

2. Risers in spiral staircases may not exceed 9.5 inches in height measured vertically from tread to tread.

(c) *Tread depth.* 1. 'Rectangular treads.' Rectangular treads shall have minimum tread depth of 9 inches measured horizontally from nosing to nosing.

2. 'Spiral staircase treads.' Spiral staircase treads shall have a minimum tread depth of 7 inches from nosing to nosing measured at a point 12 inches from the outer edge of the center column.

3. 'Winder treads in series.' Two or more winder treads may be placed immediately adjacent to each other anywhere in a stairway provided both of the following conditions are met:

a. The winder treads shall have a minimum tread depth of 7 inches measured at a point 12 inches from the narrow end of the tread.

b. The depth of the immediately adjoining winder treads shall be equal at a point 12 inches from the narrow end of the tread or inside face of spindles or balusters.

c. Winder treads may not be used on a straight stairway.

4. 'Individual winder treads.' a. An individual winder tread may be placed between rectangular treads or at the end of a flight of rectangular treads provided the tread depth, measured at a point 12 inches from the narrow end, is equal to the tread depth of the rectangular steps in the flight.

b. There may be more than one individual winder tread in a stairway or in a flight of stairs.

c. Winder treads may not be used on a straight stairway.

(d) *Headroom.* 1. Stairways shall be provided with a minimum headroom clearance of 76 inches measured vertically from a line parallel to the nosing of the treads to the ceiling, soffit or any overhead obstruction directly above that line.

2. The headroom clearance shall be maintained over an intermediate landing.

3. The headroom clearance shall be maintained over a landing that is at the top or bottom of a stairway for a minimum distance of 36 inches in the direction of travel of the stairway.

(e) *Uniformity.* 1. Within a stairway flight, the greatest tread depth may not exceed the smallest tread depth by more than 3/8 inch and the greatest riser height may not exceed the smallest riser height by more than 3/8 inch.

2. The allowed variation in uniformity under subd. 1. may not be used to exceed the maximum riser height under par. (b) or to decrease the minimum tread depth under par. (c).

(f) *Open risers.* Stairways with open risers shall be constructed to prevent the through-passage of a sphere with a diameter of 4 inches or larger between any 2 adjacent treads.

(g) *Walking surface.* The walking surface of stair treads and landings shall be a planar surface that is free of lips or protrusions that could present a tripping hazard.

(3) **HANDRAILS AND GUARDRAILS.** (a) *General.* 1. Stair flights with more than 3 risers shall be provided with at least one handrail for the full length of the stair flight.

2. Handrails or guardrails shall be provided on all open sides of stair flights consisting of more than 3 risers and on all open sides of areas that are elevated more than 24 inches above the floor or exterior grade.

**Note:** A handrail provided at 30 to 38 inches above the tread nosing meets the height requirement for a guardrail on a stairway.

3. a. Except as provided in subd. 3. b., handrails and guardrails shall be constructed to prevent the through-passage of a sphere with a diameter of 4 inches or larger.

b. The triangular area formed by the tread, riser and bottom rail shall have an opening size that prevents the through-passage of a sphere with a diameter of 6 inches or larger.

c. Rope, cable or similar materials used in handrail or guardrail infill shall be strung with maximum openings of 3½ inches with vertical supports a maximum of 4 feet apart.

**Note:** In some cases, the vertical supports could be simple cable stays that offer vertical support to the rope or cable span. Structural posts must be supplied to provide the rail with the minimum 200 pound load resistance, as well as to resist the tensile loads exerted by the tightened rope or cable.

4. a. Handrails and guardrails shall be designed and constructed to withstand a 200 pound load applied in any direction.

b. Handrail or guardrail infill components, balusters and panel fillers shall withstand a horizontally applied perpendicular load of 50 pounds on any one-foot-square area.

c. Glazing used in handrail or guardrail assemblies shall be safety glazing.

5. Exterior handrails and guardrails shall be constructed of metal, decay resistant or pressure-treated wood, or shall be protected from the weather.

(b) *Handrails.* 1. 'Height.' Handrails shall be located at least 30 inches, but no more than 38 inches above the nosing of the treads. Measurement shall be taken from the hard structural surface beneath any finish material to the top of the rail. Variations

in uniformity are allowed only when a rail contacts a wall or newel post or where a turnout or volute is provided at the bottom step.

2. 'Clearance.' The clearance between a handrail and the wall surface shall be at least 1½ inches.

3. 'Winders.' a. Except as provided under subd. 3. b., the required handrail on winder steps shall be placed on the side where the treads are wider.

b. Where all winder steps in a flight have a tread depth of at least 9 inches from nosing to nosing measured at a point 12 inches from the narrow end of the tread, the required handrail may be located on either side of the stairway.

4. 'Projection.' Handrails and associated trim may project into the required width of stairs and landings a maximum of 4½ inches on each side.

5. 'Size and configuration.' Handrails shall be symmetrical about the vertical centerline to allow for equal wraparound of the thumb and fingers.

a. Handrails with a round or truncated round cross sectional gripping surface shall have a maximum whole diameter of 2 inches.

b. Handrails with a rectangular cross sectional gripping surface shall have a maximum perimeter of 6¼ inches with a maximum cross sectional dimension of 27⁄8 inches.

c. Handrails with other cross sections shall have a maximum cross sectional dimension of the gripping surface of 27⁄8 inches with a maximum linear gripping surface measurement of 6¼ inches and a minimum linear gripping surface of 4 inches.

Note: See appendix for further information on handrail measurement.

6. 'Continuity.' Handrails shall be continuous for the entire length of the stairs except in any one of the following cases:

a. A handrail may be discontinuous at an intermediate landing.

b. A handrail may have newel posts.

c. A handrail may terminate at an intermediate wall provided the lower end of the upper rail is returned to the wall or provided with a flared end, the horizontal offset between the 2 rails is no more than 12 inches measured from the center of the rails, and both the upper and lower rails can be reached from the same tread without taking a step.

(c) *Guardrails.* 1. 'Application.' a. All openings between floors, and open sides of landings, platforms, balconies or porches that are more than 24 inches above grade or a floor shall be protected with guardrails.

b. The requirements under subd. 1. a. apply where insect screens are the only means of enclosure or protection for a surface that is more than 24 inches above grade or a floor.

c. For exterior applications, the 24 inch vertical measurement shall be taken from the lowest point within 3 feet horizontally from the edge of the deck, landing, porch or similar structure.

2. 'Height.' Guardrails shall be located at least 36 inches above the floor. Measurement shall be taken from the hard structural surface beneath any finish material to the top of the rail.

3. 'Opening size.' Guardrails shall be constructed to prevent the through-passage of a sphere with a diameter of 4 inches or larger.

(4) **LANDINGS.** (a) *Intermediate landings.* 1. A level intermediate landing shall be provided in any stairway with a height of 12 feet or more.

2. Intermediate landings that connect 2 or more straight flights of stairs, or 2 flights of stairs at a right angle, shall be at least as wide as the stairway and shall measure at least 36 inches in the direction of travel.

3. Curved or irregular landing shall have a radius of at least 36 inches.

4. Curved or irregular landings shall have a minimum straight line measurement of 26 inches between the nosing of the 2 connecting treads measured at a point 18 inches from the narrow end of the landing measured along the nosing of the 2 treads.

(b) *Landings at the top and base of stairs.* A level landing shall be provided at the top and base of every stairs. The landing shall be at least as wide as the stairs and shall measure at least 3 feet in the direction of travel.

(c) *Doors at landings.* 1. Except as provided in subd. 1. a. to c., level landings shall be provided on each side of any door located at the top or base of a stairs, regardless of the direction of swing. In the following exceptions, stairways to attached garages, carports or porches are considered interior stairs:

a. A landing is not required between the door and the top of interior stairs if the door does not swing over the stairs.

b. A landing is not required between the door and the top of an interior stairs of 1 or 2 risers regardless of the direction of swing.

c. A landing is not required between a sliding glass door and the top of an exterior stairway of 3 or fewer risers.

2. The exterior landing, platform or sidewalk at an exterior doorway shall be located a maximum of 8 inches below the interior floor elevation and shall have a length of at least 36 inches in the direction of travel out of the dwelling.

History: Cr. Register, November, 1979, No. 287, eff. 6-1-80; r. and recr. Register, February, 1985, No. 350, eff. 3-1-85; am. (intro.), r. and recr. (1) (c), renum. (3) (f) to Comm 21.042, Register, January, 1989, No. 397, eff. 2-1-89; r. and recr. (intro.) and (3) (c), am. (1) (a), (2) (a) and (c) 2. and (3) (a), cr. (2) (c) 6., March, 1992, No. 435, eff. 4-1-92; r. and recr., Register, November, 1995, No. 479, eff. 12-1-95; am. (1) (c) 1. and (d), renum. (2) (intro.) to (b) to (2) (a) to (c) and am. (a), r. (2) (b) (intro.), Register, February, 1997, No. 494, eff. 3-1-97; reprinted to restore dropped copy, Register, March, 1997, No. 495; r. (1), renum. (intro.) to be (1) and am., renum. (2) and (3) to be (3) and (4), cr. (2) and r. and recr. (4) (a), Register, March, 2001, No. 543, eff. 4-1-01; CR 02-077: am. (2) (b) 1., (e) 1. and (3) (a), cr. (2) (f) and (3) (c) 3., r. and recr. (3) (b) 3., renum. (4) (c) to be (4) (c) 1. (intro.), a. to c. and 2. and am. (4) (c) 1. (intro.) and 2. Register May 2003, No. 569, eff. 8-1-03; CR 03-097: am. (2) (f), (3) (a) 3., and (c) 3. Register November 2004 No. 587, eff. 1-1-05; CR 08-043: r. and recr. (1), am. (2) (c) 2., 3. b. and (e) 1., cr. (2) (c) 3. c., 4. c., (g), (3) (a) 3. c., 4. b., c., (c) 1. b. and c., renum. (3) (a) 4. and (c) 1. to be (3) (a) 4. a. and (c) 1. a. Register March 2009 No. 639, eff. 4-1-09.

**Comm 21.042 Ladders.** Ladders which are used as part of a required exit shall conform to this section.

(1) **DESIGN LOAD.** Ladders shall be designed to withstand loads of at least 200 pounds.

(2) **TREAD OR RUNGS.** (a) Minimum tread requirements shall be specified in Table 21.042. Treads less than 9 inches in width shall have open risers. All treads shall be uniform in dimension.

TABLE 21.042

Pitch of Ladder Angle to Horizontal (degrees)	Maximum rise (inches)	Minimum Tread (inches)
41.6 to 48.4	8	9
greater than 48.4 to 55.0	9	8
greater than 55.0 to 61.4	10	7
greater than 61.4 to 67.4	11	6
greater than 67.4 to 71.6	12	5
greater than 71.6 to 75.9	12	4
greater than 75.9 to 80.5	12	3
greater than 80.5 to 90	12	2

(b) Rungs may only be used for ladders with a pitch range of 75° to 90°. Rungs shall be at least 1 inch in diameter for metal ladders and 1½ inch for wood ladders. All rungs shall be uniform in dimension.

(3) **RISERS.** Risers shall be uniform in height and shall conform with Table 21.042.

(4) **WIDTH.** The width of the ladder shall be a minimum of 20 inches wide and a maximum of 30 inches wide.

(5) **HANDRAILS.** (a) Handrails shall be required for ladders with pitches less than 65°.

(b) Handrails shall be located so the top of the handrail is at least 30 inches, but not more than 38 inches, above the nosing of the treads.

(c) Open handrails shall be provided with intermediate rails or an ornamental pattern such that a sphere with a diameter of 6 inches or larger cannot pass through.

(d) The clearance between the handrail and the wall surface shall be at least 1½ inches.

(c) Handrails shall be designed and constructed to withstand a 200 pound load applied in any direction.

(6) CLEARANCES. (a) The ladder shall have a minimum clearance of at least 15 inches on either side of the center of the tread.

(b) The edge of the tread nearest to the wall behind the ladder shall be separated from the wall by at least 7 inches.

(c) A passage way clearance of at least 30 inches parallel to the slope of a 90° ladder shall be provided. A passage way clearance of at least 36 inches parallel to the slope of a 75° ladder shall be provided. Clearances for intermediate pitches shall vary between these 2 limits in proportion to the slope.

(d) For ladders with less than a 75° pitch the vertical clearance above any tread or rung to an overhead obstruction shall be at least 6 feet 4 inches measured from the leading edge of the tread or rung.

**History:** Renum. from Comm 21.04 (3) (f), cr. (intro.), Register, January, 1989, No. 397, eff. 2-1-89; am. (6) (b), Register, November, 1995, No. 479, eff. 12-1-95; am. (5) (b) and (c), Register, January, 1999, No. 517, eff. 2-1-99.

**Comm 21.045 Ramps. (1) GENERAL.** Every exterior or interior ramp which leads to or from an exit shall comply with the requirements of this section.

**Note:** See ICC/ANSI A117.1 chapter 5 for more guidelines relating to the design and construction of an accessible ramp. Under that standard, ramps along an accessible route for people with disabilities should have a slope of not more than 1-foot of rise in 12-feet of run and should have handrails on both sides of the ramp.

(2) SLOPE. Ramps shall not have a gradient greater than 1 in 8 or one foot of rise in 8 feet of run. Walkways with gradients less than 1 in 20 or one foot of rise in 20 feet of run are not considered to be ramps.

(3) SURFACE AND WIDTH. Ramps shall have a slip resistant surface and shall have a minimum width of 36 inches measured between handrails.

(4) HANDRAILS. Handrails shall be provided on all open sides of ramps. Every ramp that overcomes a change in elevation of more than 8 inches shall be provided with at least one handrail.

(a) Ramps which have a gradient greater than 8.33% or 1:12 or one foot rise in 12 feet of run and which overcome a change in elevation of more than 24 inches, shall be provided with handrails on both sides.

(b) Handrails shall be located so the top of the handrail is at least 30 inches, but not more than 38 inches above the ramp surface.

(c) Open-sided ramps shall have the area below the handrail protected by intermediate rails or an ornamental pattern to prevent the passage of a sphere with a diameter of 4 inches or larger.

(d) The clear space between the handrail and any adjoining wall shall be at least 1½ inches.

(5) LANDINGS. A level landing shall be provided at the top, at the foot and at any change in direction of the ramp. The landing shall be at least as wide as the ramp and shall measure at least 3 feet in the direction of travel.

**History:** Cr. Register, January, 1989, No. 397, eff. 2-1-89; am. (3) (intro.), Register, March, 1992, No. 435, eff. 4-1-92; am. (3) (c), Register, November, 1995, No. 479, eff. 12-1-95; am. (3) (b), Register, January, 1999, No. 517, eff. 2-1-99; CR 03-097; am. (3) (c) Register November 2004 No. 587, eff. 1-1-05; CR 08-043; renum. (intro.) and (1) to (4) to be (1) to (5) and am. (1) Register March 2009 No. 639, eff. 4-1-09.

**Comm 21.05 Natural light and natural ventilation.**

(1) NATURAL LIGHT. All habitable rooms shall be provided with natural light by means of glazed openings. The area of the glazed openings shall be at least 8% of the net floor area, except under the following circumstances:

(a) *Exception.* Habitable rooms, other than bedrooms, located in basements or ground floors do not require natural light.

(b) *Exception.* Natural light may be obtained from adjoining areas through glazed openings, louvers or other approved methods. Door openings into adjoining areas may not be used to satisfy this requirement.

(2) VENTILATION. (a) *Natural ventilation.* Natural ventilation shall be provided to all habitable rooms by means of openable doors, skylights or windows. The net area of the openable doors, skylights or windows shall be at least 3.5% of the net floor area of the room. Balanced mechanical ventilation may be provided in lieu of openable exterior doors, skylights or windows provided the system is capable of providing at least one air change per hour of fresh outside air while the room is occupied. Infiltration may not be considered as make-up air for balancing purposes.

(b) *Exhaust ventilation.* All exhaust ventilation shall terminate outside the building.

(3) SAFETY GLASS. Except as provided in par. (c), glazing shall consist of safety glass meeting the requirements of CPSC 16 CFR, Part 1201 when installed in any of the following locations:

(a) In any sidelight or glazing adjacent to a door that meets all of the following:

1. The nearest point of the glazing is within 2 feet of the door.
2. The nearest point of the glazing is within 5 feet of the floor.
3. The plane of the glazing is within 30 degrees of the plane of the door when the door is in the closed position.

(b) In any wall where the glazing is within 5 feet vertically of the lowest drain inlet and within 3 feet horizontally of the nearest part of the inner rim of a bathtub, hot tub, shower, spa or whirlpool appliance.

(c) Within 4 feet vertically of a tread or landing in a stairway and within one foot horizontally of the near edge of the tread or landing.

(d) Within 4 feet vertically of the floor and 3 feet horizontally of the nosing of the top or bottom tread of a stair.

(e) Safety glass is not required where the size of an individual pane of glass is 8 inches or less in the least dimension.

**Note:** The U.S. Consumer Product Safety Commission requires safety glass for glazing in internal and external doors, including storm doors and patio doors, as well as for the tub or shower enclosures themselves. These federal rules, contained in 16 CFR, subchapter B, part 1201, apply in addition to any state rules or statutes.

**Note:** Glass blocks are considered to be masonry products and are regulated under the ACI 530 standard adopted under s. Comm 20.24. They are not required to be safety glazing.

**History:** Cr. Register, November, 1979, No. 287, eff. 6-1-80; r. and recr. (1) and (2), Register, February, 1985, No. 350, eff. 3-1-85; r. and recr. (3) and (4), Register, July, 1986, No. 367, eff. 1-1-87; am. (4), Register, January, 1989, No. 397, eff. 2-1-89; am. (2) (a), (4) and (5), Register, March, 1992, No. 435, eff. 4-1-92; am. (2) (a), Register, November, 1995, No. 479, eff. 12-1-95; am. (3), r. and recr. (4) and (5), Register, January, 1999, No. 517, eff. 2-1-99; CR 02-077; am. (1) (a) and (5) (b) Register May 2003 No. 569, eff. 8-1-03; CR 08-043; am. (title), r. (3) and (4), renum. (5) to be (3) and am. (3) (intro.), r. and recr. (3) (a) and (b) Register March 2009 No. 639, eff. 4-1-09.

**Comm 21.06 Ceiling height.** All habitable rooms, kitchens, hallways, bathrooms and corridors shall have a ceiling height of at least 7 feet. Habitable rooms may have ceiling heights of less than 7 feet provided at least 50% of the room's floor area has a ceiling height of at least 7 feet. Beams and girders or other projections shall not project more than 8 inches below the required ceiling height.

**History:** Cr. Register, November, 1979, No. 287, eff. 6-1-80; r. and recr. Register, February, 1985, No. 350, eff. 3-1-85.

**Comm 21.07 Attic and crawl space access.**

(1) ATTIC. Attics with 150 or more square feet of area and 30 or more inches of clear height between the top of the ceiling framing and the bottom of the rafter or top truss chord framing shall be provided with an access opening of at least 14 by 24 inches, accessible from inside the structure.

(2) CRAWL SPACES. Crawl spaces with 18 inches of clearance or more between the crawl space floor and the underside of the house floor joist framing shall be provided with an access opening of at least 14 by 24 inches.

**Note:** Access to plumbing or electrical systems may be required under chs. Comm 82-87, Plumbing Code or ch. Comm 16, Electrical Code, Volume 2.

**History:** Cr. Register, November, 1979, No. 287, eff. 6-1-80; am. Register, March, 1992, No. 435, eff. 4-1-92; am. (1), Register, November, 1995, No. 479, eff. 12-1-95.

**Comm 21.08 Fire separation and dwelling unit separation. (1) FIRE SEPARATION.** Dwelling units shall be separated

from garage spaces, accessory buildings, property lines and other dwelling units in accordance with Table 21.08 and the following requirements:

TABLE 21.08

Between Dwelling And:	Distance Between Objects <sup>1</sup>	Fire Rated Construction <sup>2,5</sup>
Detached garage or accessory building on same property	Less than 5 feet	3/4-hour wall <sup>3</sup> 1/3-hour door or window <sup>3</sup>
Another dwelling on same property	Less than 5 feet	3/4-hour wall <sup>4</sup> 1/3-hour door or window <sup>4</sup>
Detached garage, accessory building, or other dwelling on same property	5 to 10 feet	3/4-hour wall <sup>3</sup> No requirement on openings
Detached garage, accessory building, or other dwelling on same property	More than 10 feet	No requirements
Property Lines	Less than 3 feet	3/4-hour wall 1/3-hour door or window
Property Lines	3 feet or more	No Requirements
Zero Lot Line	None	Follow sub. (2) (d) requirements

<sup>1</sup>Distance shall be measured perpendicular from wall to wall or property line, ignoring overhangs.

<sup>2</sup>Fire rated construction shall protect the dwelling from an exterior fire source.

<sup>3</sup>Fire rated construction may be in either facing wall.

<sup>4</sup>Fire rated construction shall be in both facing walls.

<sup>5</sup>The methods for garage separation in par. (a) 1. are examples of 3/4 hour wall construction.

(a) *Attached garages.* 1. The walls and ceiling between an attached garage and any portion of the dwelling, including attic or soffit areas, shall be 3/4-hour fire-resistive construction or shall be constructed as specified in any of the following:

a. One layer of 5/8-inch Type X gypsum drywall shall be used on the garage side of the separation wall or ceiling.

b. One layer of 1/2-inch gypsum drywall shall be used on each side of the separation wall or ceiling.

c. Two layers of 1/2-inch gypsum drywall shall be used on the garage side of the separation wall or ceiling.

2. For all methods listed under subd. 1., drywall joints shall comply with one of the following:

a. Joints shall be taped or sealed.

b. Joints shall be fitted so that the gap is no more than 1/20-inch with joints backed by either solid wood or another layer of drywall such that the joints are staggered.

Note: 1/20-inch is approximately the thickness of a U.S. dime.

3. Vertical separations between an attached garage and a dwelling shall extend from the top of a concrete or masonry foundation to the underside of the roof sheathing or fire-resistive ceiling construction.

(b) *Structural elements exposed in an attached garage.* Beams, columns and bearing walls which are exposed to the garage and which provide support for habitable portions of the dwelling shall be protected by one of the methods specified in par. (a) 1. a. or c. or other 3/4 hour fire-resistive protection.

(c) *Doors.* 1. The door and frame assembly between the dwelling unit and an attached garage shall be labeled by an independent testing agency as having a minimum fire-resistive rating of 20 minutes. The test to determine the 20-minute rating is not required to include the hose stream portion of the test.

Note: Acceptable tests for fire rating of door assemblies include ASTM E-152, UL 10B, and NFPA 252.

2. Only glazing allowed by the door's listing may be installed in any door required under this section.

(d) *Other openings.* 1. Access openings in fire separation walls or ceilings shall be protected in one of the following ways:

a. The opening is protected with a material that has a finish rating of at least 20 minutes.

b. The opening is protected in the same way as the wall or ceiling where the opening is located.

2. The cover or door of the access opening shall be permanently installed with hardware that will maintain it in the closed position when not in use.

(2) *DWELLING UNIT SEPARATION.* (a) *General.* In 2-family dwellings, dwelling units shall be separated from each other and from shared tenant spaces including attics, basements, garages, vestibules and corridors.

(b) *Attic separation.* Dwelling units with attic space that extends over both units shall be separated in accordance with one of the following:

1. 'Complete separation.' The units shall be provided with wall construction under par. (d) that extends all the way to the underside of the roof deck.

2. 'Vertical and horizontal separation.' a. The units shall be provided with wall construction under par. (d) that extends to the dwelling unit ceiling and ceiling construction under par. (e).

b. Dwelling units using this method of separation shall provide attic draft stopping under par. (f) that extends all the way to the underside of the roof deck above and in line with the separation wall.

(c) *Doors.* Any door installed in the dwelling unit separation shall have the door and frame assembly labeled by an independent testing agency as having a minimum fire-resistive rating of 20 minutes. The test to determine the 20-minute rating is not required to include the hose stream portion of the test.

(d) *Walls.* Walls in the dwelling unit separation shall be protected by not less than one layer of 5/8-inch Type X gypsum wallboard or 2 layers of 1/2-inch gypsum wallboard or equivalent on each side of the wall with joints in compliance with sub. (1) (a) 2.

(e) *Floors and ceilings.* A fire protective membrane of one layer of 5/8-inch Type X gypsum wallboard with joints in compliance with sub. (1) (a) 2., shall be provided on the ceiling beneath the floor construction that provides the separation.

(f) *Draft stopping for concealed roof spaces and attics.* 1. Attic areas, mansards, overhangs and other concealed roof spaces shall be draft stopped above and in line with the separation wall.

2. Acceptable draft stopping materials include:

a. 3/8-inch wood structural panel.

b. 1/2-inch gypsum board.

(3) *PENETRATIONS.* (a) *Ducts.* 1. Except as allowed under subd. 2., all heating and ventilating ducts that penetrate a required separation shall be protected with a listed fire damper with a rating of at least 90 minutes.

2. The fire damper required under subd. 1. may be omitted in any of the following cases:

a. There is a minimum of 6 feet of continuous steel ductwork on at least one side of the penetration.

b. The duct has a maximum cross-sectional area of 20 square inches.

(b) *Electrical and plumbing components.* Penetrations of a required separation by electrical and plumbing components shall be firmly packed with noncombustible material or shall be protected with a listed through-penetration firestop system with a rating of at least one hour.

**History:** Cr. Register, November, 1979, No. 287, eff. 6-1-80; r. and recr. Register, February, 1985, No. 350, eff. 3-1-85; cr. (1m), am. (2), (5) (c) and Table, Register, January, 1989, No. 397, eff. 2-1-89; am. (2), (4) and (5) (a) (intro.), renum. (5) (b) and (c) to be (5) (c) and (d) and am. (5) (d), cr. (5) (b) and (c), (6), Register, March, 1992, No. 435, eff. 4-1-92; r. (3) (a), (5) (d), renum. (3) (b) and (c), (5) (e) to be (3) (a) and (b), (5) (d), am. (5) (a) (intro.), (6), cr. (6) (c) to (e), Register, November, 1995, No. 479, eff. 12-1-95; r. and recr. (5) and (6) (b), am. (6) (c) and (d), r. (6) (e) and cr. (7), Register, January, 1999, No. 517, eff. 2-1-99; r. (1) to (4), renum. (5) to (7) to be (1) to (3), and cr. (2) (e), Register, March, 2001, No. 543, eff. 4-1-01; corrections in (2) (c) and (d) were made under s. 13.93 (2m) (b) 7., Stats., Register, March, 2001, No. 543; CR 02-077: am. (1) (a) 1. and (2) (a) to (c) Register May 2003 No. 569, eff. 8-1-03; CR 08-043: am. (1) (intro.) and Table, r. (1) (a) 4. and (2) (e), renum. (1) (c), (2) (b), (c) and (d) to be (1) (c) 1., (2) (c), (d) and (c) and am. (2) (d), cr. (1) (c) 2., (2) (b) and (f), r. and recr. (1) (d) 1. and (2) (a) Register March 2009 No. 639, eff. 4-1-09; correction in Table 21.08 made under s. 13.92 (4) (b) 7., Stats., Register March 2009 No. 639.



**Comm 21.085 Fireblocking.** (1) FIREBLOCKING LOCATIONS. Fireblocking shall be provided in all of the following locations:

(a) In concealed spaces of walls and partitions, including furred spaces, at the ceiling and floor levels.

(b) At all interconnections between concealed vertical and horizontal spaces including the attachment between a carport and a dwelling.

(c) In concealed spaces between stair stringers at the top and bottom of the run and at any intervening floor level.

(d) At all openings around wires, cables, vents, pipes, ducts, chimneys and fireplaces at ceiling and floor level.

(2) FIREBLOCKING MATERIALS. Fireblocking shall consist of one of the following:

(a) 2-inch nominal lumber.

(b) Two layers of one-inch nominal lumber.

(c) One thickness of 3/4-inch nominal plywood or wood structural panel with any joints backed with the same material.

(d) One thickness of 1/2-inch gypsum wallboard, face nailed or face screwed to solid wood, with any joints backed with the same material.

(e) Fiberglass or mineral wool batt insulation may be used if both of the following conditions are met:

1. The least dimension of the opening may not exceed 4 inches.

2. The batt shall be installed to fill the entire thickness of the opening or stud cavity.

(f) For wires, cables, pipes and vents only, non-shrinking caulk, putty mortar, or similar material may be used provided no dimension of the opening exceeds 1/2 inch around the penetrating object.

(g) For chimneys, fireplaces and metal vents, fireblocking shall be metal, cement board or other noncombustible material.

**History:** Cr. Register, March, 2001, No. 543, eff. 4-1-01; CR 02-077; am. (1) (b) Register May 2003 No. 569, eff. 8-1-03.

**Comm 21.09 Smoke detectors.** (1) A listed and labeled multiple-station smoke alarm with battery backup shall be installed in all of the following locations:

(a) An alarm shall be installed inside each sleeping room.

(b) On floor levels that contain one or more sleeping areas, an alarm shall be installed outside of the sleeping rooms, within 21 feet of the centerline of the door opening to any sleeping room and in an exit path from any sleeping room.

(c) On floor levels that do not contain a sleeping area, an alarm shall be installed in a common area on each floor level.

**Note:** Section 50.035 (2), Stats., requires the installation of a complete low voltage, interconnected or radio-transmitting smoke detection system in all community-based residential facilities including those having 8 or fewer beds.

**Note:** Section 101.645 (3), Stats., requires the owner of a dwelling to install a functional smoke detector in the basement of the dwelling and on each floor level except the attic or storage area of each dwelling unit. The occupant of such a dwelling unit shall maintain any smoke detector in that unit, except that if any occupant who is not the owner, or any state, county, city, village or town officer, agent or employee charged under statute or municipal ordinance with powers or duties involving inspection of real or personal property, gives written notice to the owner that the smoke detector is not functional the owner shall provide, within 5 days after receipt of that notice, any maintenance necessary to make that smoke detector functional.

**Note:** Section 101.745 (4), Stats., requires the manufacturer of a manufactured building to install a functional smoke detector in the basement of the dwelling and on each floor level except the attic or storage area of each dwelling unit.

(2) (a) Except for dwellings with no electrical service, smoke detectors required by this section shall be continuously powered by the house electrical service, and shall be interconnected so that activation of one detector will cause activation of all detectors.

(b) Dwellings with no electrical service shall be provided with battery-powered smoke detectors in the locations under sub. (1). Interconnection and battery-backup are not required in these dwellings.

(3) For family living units with one or more communicating split levels or open adjacent levels with less than 5 feet of separation between levels, one smoke detector on the upper level shall suffice for an adjacent lower level, including basements. Where

there is an intervening door between one level and the adjacent lower level, smoke detectors shall be installed on each level.

(4) Smoke alarms and detectors shall be maintained in accordance with the manufacturer's specifications.

(5) For envelope dwellings, at least 3 smoke alarms shall be placed in the air passageways. The alarms shall be placed as far apart as possible.

(6) In basements where two required exits are separated by a continuous wall, a smoke detector shall be placed on each side of the wall within 21 feet of each exit.

**History:** Cr. Register, November, 1979, No. 287, eff. 6-1-80; r. and recr. Register, February, 1985, No. 350, eff. 3-1-85; r. and recr. Register, April, 1990, No. 412, eff. 5-1-90; renum. to be (1), cr. (2) and (3), Register, March, 1992, No. 435, eff. 4-1-92; renum. (2) and (3) to be (3) and (4), cr. (2), Register, November, 1995, No. 479, eff. 12-1-95; r. and recr. (1), r. (2), renum. (3) and (4) to be (2) and (3), and cr. (4) and (5), Register, March, 2001, No. 543, eff. 4-1-01; CR 08-043; am. (1) (b) and (3), renum. (2) to be (2) (a) and am., cr. (2) (b) and (6) Register March 2009 No. 639, eff. 4-1-09.

**Comm 21.095 Automatic fire sprinklers.** (1) Except as allowed under sub. (2), where automatic fire sprinklers using a dedicated water supply system are installed, the design, installation, testing and maintenance shall follow the requirements of NFPA 13D.

(2) Limited area dwelling systems are allowed.

**Note:** See s. Comm 82.40 (3) (e) of the Wisconsin Uniform Plumbing Code for requirements for multi-purpose piping systems. These systems attach fire sprinkler heads to the dwelling's potable water piping system.

**Note:** Chapter 145, Stats., requires automatic fire sprinkler systems, on dedicated water supply systems, to be installed by a licensed sprinkler fitter.

**History:** CR 08-043; cr. Register March 2009 No. 639, eff. 4-1-09.

**Comm 21.097 Carbon monoxide alarms.** (1) (a) Listed and labeled carbon monoxide alarms with battery secondary power supplies shall be installed and maintained in dwellings to be utilized as licensed tourist rooming houses and that contain fuel-burning appliances in accordance with s. 101.149 (2) and (3), Stats.

**Note:** Section 101.149 (2) and (3), Stats., reads:

(2) INSTALLATION REQUIREMENTS. (a) Except as provided in par. (b), the owner of a residential building shall install a carbon monoxide detector in all of the following places not later than the date specified under par. (c):

1. In the basement of the building if the basement has a fuel-burning appliance.

2. Within 15 feet of each sleeping area of a unit that has a fuel-burning appliance.

3. Within 15 feet of each sleeping area of a unit that is immediately adjacent to a unit that has a fuel-burning appliance.

4. In each room that has a fuel-burning appliance and that is not used as a sleeping area. A carbon monoxide detector shall be installed under this subdivision not more than 75 feet from the fuel-burning appliance.

5. In each hallway leading from a unit that has a fuel-burning appliance, in a location that is within 75 feet from the unit, except that, if there is no electrical outlet within this distance, the owner shall place the carbon monoxide detector at the closest available electrical outlet in the hallway.

(b) If a unit is not part of a multiunit building, the owner of the residential building need not install more than one carbon monoxide detector in the unit.

(c) 1. Except as provided under subd. 2., the owner of a residential building shall comply with the requirements of this subsection before the building is occupied.

2. The owner of a residential building shall comply with the requirements of this subsection not later than April 1, 2010, if construction of the building was initiated before October 1, 2008, or if the department approved the plans for the construction of the building under s. 101.12, Stats., before October 1, 2008.

(d) Any carbon monoxide detector that bears an Underwriters Laboratories, Inc., listing mark or similar mark from an independent product safety certification organization satisfies the requirements of this subsection.

(e) The owner shall install every carbon monoxide detector required by this subsection according to the directions and specifications of the manufacturer of the carbon monoxide detector.

(3) MAINTENANCE REQUIREMENTS. (a) The owner of a residential building shall reasonably maintain every carbon monoxide detector in the residential building in the manner specified in the instructions for the carbon monoxide detector.

(b) An occupant of a unit in a residential building may give the owner of the residential building written notice that a carbon monoxide detector in the residential building is not functional or has been removed by a person other than the occupant. The owner of the residential building shall repair or replace the nonfunctional or missing carbon monoxide detector within 5 days after receipt of the notice.

(c) The owner of a residential building is not liable for damages resulting from any of the following:

1. A false alarm from a carbon monoxide detector if the carbon monoxide detector was reasonably maintained by the owner of the residential building.

2. The failure of a carbon monoxide detector to operate properly if that failure was the result of tampering with, or removal or destruction of, the carbon monoxide detector by a person other than the owner or the result of a faulty alarm that was reasonably maintained by the owner as required under par. (a).

(b) In this section:

1. "Fuel-burning appliance" means a device that is installed in a dwelling and burns fossil-fuel or carbon based fuel where carbon monoxide is a combustion by-product, including stoves, ovens, grills, clothes dryers, furnaces, boilers, water heaters, heaters, fireplaces and stoves.

2. "Tourist rooming house" has the meaning as given under s. DHS 195.03 (20).

**Note:** Section DHS 195.03 (20) reads: "Tourist rooming house" means all lodging places and tourist cabins and cottages, other than hotels and motels, in which sleeping accommodations are offered for pay to tourists or transients. It does not include private boarding or rooming houses not accommodating tourists or transients, or bed and breakfast establishments regulated under ch. DHS 197.

(2) Carbon monoxide alarms shall be wired to the dwelling's electrical service.

(3) Carbon monoxide alarms within a dwelling unit shall be interconnected so that activation of one alarm will cause activation of all alarms within the dwelling unit.

(4) Carbon monoxide alarms shall conform to UL 2034.

(5) The installation of carbon monoxide alarms or detectors in adjacent units required under s. 101.149 (2) (a) 3., Stats., shall apply to those units located on the same floor level.

(6) Pursuant to s. 101.149 (6) (b), Stats., the department may issue orders for a violation of the provisions of this section.

(7) Violation of the provisions of this section shall be subject to the penalties provided under s. 101.149 (8), Stats.

**Note:** Section 101.149 (8), Stats., reads:

(8) PENALTIES. (a) If the department of commerce or the department of health and family services determines after an inspection of a building under this section or s. 254.74 (1g) that the owner of the building has violated sub. (2) or (3), the respective department shall issue an order requiring the person to correct the violation within 5 days or within such shorter period as the respective department determines is necessary to protect public health and safety. If the person does not correct the violation within the time required, he or she shall forfeit \$50 for each day of violation occurring after the date on which the respective department finds that the violation was not corrected.

(b) If a person is charged with more than one violation of sub. (2) or (3) arising out of an inspection of a building owned by that person, those violations shall be counted as a single violation for the purpose of determining the amount of a forfeiture under par. (a).

(c) Whoever violates sub. (4) is subject to the following penalties:

1. For a first offense, the person may be fined not more than \$10,000 or imprisoned for not more than 9 months, or both.

2. For a 2nd or subsequent offense, the person is guilty of a Class I felony.

**History:** EmR0826; emerg. cr. eff. 10-1-08; CR 08-085; cr. Register May 2009 No. 641, eff. 6-1-09; renumbered under s. 13.92 (4) (b) 1. and corrections in (1) (b) 2. and (6) made under s. 13.92 (4) (b) 7., Stats., Register May 2009 No. 641.

**Comm 21.10 Protection against decay and termites.** (1) Wood used in any of the applications under this section shall meet all of the following requirements:

(a) The wood shall be labeled and pressure treated with preservative in accordance with an AWP standard or shall be naturally durable and decay-resistant or shall be engineered to be decay resistant.

(b) The wood shall be pressure treated with preservative or shall be naturally termite-resistant unless additional steps are taken to make the wood termite-resistant.

(2) Wood used in the following locations shall be as required under sub. (1):

(a) Resting directly upon or embedded in earth.

(b) Floor joists or sleepers that meet all of the following conditions:

1. The joists or sleepers are protected from the weather.

2. The joists or sleepers are within 18 inches above a lower floor surface, deck or soil.

3. There is no vapor retarder that meets the requirements under s. Comm 22.38 (1) (a) between the joists or sleepers and the soil below.

**Note:** This situation could occur with a floor over a crawl space or when a floor is added over a patio deck or a garage slab.

(c) Floor joists exterior to the dwelling that are within 18 inches above exterior grade, unless protected with a moisture barrier.

**Note:** Acceptable moisture barriers for this application include 3/4-inch exterior preservative-treated plywood, or ice dam protection material listed as meeting the requirements of ASTM D 1970 or vapor retarder material, provided they are protected from physical and UV light damage.

(d) Girders that span directly over and within 12 inches of earth.

(e) Sills and rim joists that rest on concrete or masonry and are also below grade or within 8 inches above final exterior grade.

(f) Siding and sheathing in contact with concrete, masonry or earth and within 6 inches above final exterior grade.

(g) Ends of wood structural members and their shims resting on or supported in masonry or concrete walls and having clearances of less than 1/2 inch on the top, sides and ends.

(h) Bottom plates or sole plates of walls that rest on concrete or masonry and that are below exterior grade or less than 8 inches above final exterior grade.

(i) Columns in direct contact with concrete or masonry unless supported by a structural pedestal or plinth block at least one inch above the floor.

(j) Any structural part of an outdoor deck, including the decking.

(k) Permanent wood foundations.

(3) Wood girders that rest directly on exterior concrete or masonry shall be protected by one of the following methods:

(a) The wood shall be pressure treated with preservative or shall be a naturally durable and decay-resistant species.

(b) Material, such as pressure-treated plywood, flashing material, steel shims, or water-resistant membrane material shall be placed between the wood and the concrete or masonry.

(4) All pressure-treated wood and plywood shall be identified by a quality mark or certificate of inspection of an approved inspection agency which maintains continued supervision, testing and inspection over the quality of the product.

**Note:** Heartwood of redwood, cypress, black walnut, catalpa, chestnut, sage orange, red mulberry, white oak, or cedar lumber are considered by the department to be naturally decay-resistant. Heartwood of bald cypress, redwood, and eastern red cedar are considered by the department to be naturally termite resistant.

(5) FASTENERS. (a) Fasteners for pressure-preservative treated wood and fire-retardant-treated wood shall meet one of the following requirements:

1. The fastener is a steel bolt with a diameter of 0.5 inch or greater.

2. The fastener is made of stainless steel.

3. The fastener is made of hot-dipped, zinc-galvanized steel with the coating weight and thickness labeled as complying with ASTM A 153.

4. The fastener is made of steel with a mechanically-deposited zinc coating labeled as complying with ASTM B 695, Class 55 or greater.

5. The fastener has coating types and weights in accordance with the fastener manufacturer's recommendations. In the absence of the manufacturer's recommendations subd. 1., 2., 3., or 4. shall apply.

**Note:** "Zinc plated," "zinc coated," "chrome plated," etc., fasteners do not necessarily comply with either of these standards.

(b) When a fastener is used with a hanger or other metal fixture, the fastener shall be of the same material as the hanger or metal fixture.

**Note:** When separate pieces are in close contact, zinc corrodes rapidly in the presence of plain steel. Zinc corrodes much more rapidly in the presence of stainless steel.

(c) For the purposes of this section, a fastener includes nails, screws and bolts, along with nuts and washers.

**History:** Cr. Register, November, 1979, No. 287, eff. 6-1-80; r. and recr. Register, February, 1985, No. 350, eff. 3-1-85; am. (1) (b) and (3), Register, January, 1989, No. 397, eff. 2-1-89; r. and recr. (1) (intro.) and (b), am. (1) (f), renum. (3) (intro.) to be (3) (a), cr. (3) (b), Register, March, 1992, No. 435, eff. 4-1-92; am. (1) (a), (b), (3), cr. (1) (g), Register, November, 1995, No. 479, eff. 12-1-95; r. (1) and (2), renum. (3) to be (4), and cr. (1) to (3), Register, March, 2001, No. 543, eff. 4-1-01; CR 02-077; am. (4) (a) Register May 2003 No. 569, eff. 8-1-03; CR 08-043; am. (1), (2) (a) and (i), r. and recr. (2) (b) and (h), r. (2) (g) and (4) (b), renum. (2) (c) to (f) and (4) (a) to be (2) (d) to (g) and (4) and am. (2) (e), (f) 1. and (g), cr. (2) (c), (k) and (5) Register March 2009 No. 639, eff. 4-1-09; correction in (2) (a) 3. made under s. 13.92 (4) (b) 7., Stats., Register March 2009 No. 639.

**Comm 21.11 Foam plastic.** (1) (a) *General.* Foam plastic insulation shall have a flame-spread rating of 75 or less and a smoke-developed rating of 450 or less when tested in accordance with ASTM E-84.

(b) *Thermal barrier.* Except as provided in par. (c), foam plastic insulation shall be separated from the interior of the dwelling by one of the following thermal barriers:

1. ½-inch gypsum wallboard.
2. ½-inch nominal wood structural panel.
3. ¾-inch sawn lumber with tongue-and-groove or lap joints.
4. 1-inch of masonry or concrete.
5. A product or material shown by an independent laboratory to limit the temperature rise on the unexposed surface to 250°F for 15 minutes when tested in accordance with ASTM E-119.
6. For doors only, sheet metal with a minimum thickness of 26 standard steel gauge or aluminum with a minimum thickness of 0.032 inch.

*Note:* Number 26 standard steel gauge is approximately equal to 0.018-inch.

(c) *Exemptions from thermal barrier requirement.* The following applications of foam plastic do not require a thermal barrier:

1. On overhead garage doors.
2. In the box sill of the basement or ground floor, above the bottom of the floor joists.

(2) Insulation that does not meet the requirements of this section may be approved by the department in accordance with s. Comm 20.18. Approval will be based on tests that evaluate materials or products representative of actual end-use applications.

*Note:* See s. Comm 22.04 (2) for requirements for protecting foam plastic on the exterior of a dwelling.

*History:* Cr. Register, November, 1979, No. 287, eff. 6-1-80; am. (1) (b), Register, January, 1989, No. 397, eff. 2-1-89; r. and recr. (1) (intro.), am. (1) (a), renum. (1) (b) and (c) to be (1) (c) and (d) and am. (1) (c), cr. (1) (b), Register, March, 1992, No. 435, eff. 4-1-92; am. (1) (d), (2), Register, November, 1995, No. 479, eff. 12-1-95; r. and recr. Register, March, 2001, No. 543, eff. 4-1-01.

**Comm 21.115 Installation of elevators or dumbwaiters.** Elevators or dumbwaiters serving dwelling units shall comply with the requirements under ch. Comm 18.

*History:* CR 08-030: cr. Register December 2008 No. 636, eff. 1-1-09.

### Subchapter III — Excavations

**Comm 21.12 Grade.** The finished grade of the soil shall slope away from the dwelling at a rate of at least ½-inch per foot for a minimum distance of 10 feet, or to the lot line, whichever is less.

*History:* Cr. Register, November, 1979, No. 287, eff. 6-1-80; CR 02-077: am. Register May 2003 No. 569, eff. 8-1-03.

**Comm 21.125 Erosion control and sediment control.** (1) **GENERAL.** (a) Where land disturbing construction activity is to occur erosion and sediment control practices shall be employed, as necessary, and maintained to prevent or reduce the potential deposition of soil or sediment to all of the following:

1. The waters of the state.
2. Adjacent properties.

(b) Land disturbing construction activities, except those activities necessary to implement erosion or sediment control practices, may not begin until the sediment control practices are in place for each area to be disturbed in accordance with the approved plan.

(c) Erosion and sediment control practices shall be maintained until the disturbed areas are stabilized. A disturbed area shall be considered stabilized by vegetation when a perennial cover has been established with a density of at least 70%.

(d) Erosion and sediment control practices shall either be approved by the department or listed by the department of natural resources in accordance with the process under s. NR 151.32 (2).

*Note:* Listed practices can be found through the Safety and Buildings Division website at [www.commerce.state.wi.us/SB](http://www.commerce.state.wi.us/SB) or by contacting the Safety and Buildings Division at (608) 266-3151.

(2) **MANDATED PRACTICES.** Specific practices at each site where land disturbing construction activity is to occur shall be utilized to prevent or reduce all of the following:

(a) The deposition of soil from being tracked onto streets by vehicles.

(b) The discharge of sediment from disturbed areas into on-site storm water inlets.

(c) The discharge of sediment from disturbed areas into abutting waters of the state.

(d) The discharge of sediment from drainage ways that flow off the site.

(e) The discharge of sediment by dewatering activities.

(f) The discharge of sediment eroding from soil stockpiles existing for more than 7 days.

(3) **CONTROL STANDARDS.** Including the practices under sub. (2), additional erosion and sediment control practices shall be employed, as necessary, to accomplish one of the following:

(a) A potential annual cumulative soil loss rate of not more than one of the following:

1. Five tons per acre per year where sand, loamy sand, sandy loam, loam, sandy clay loam, clay loam, sandy clay, silty clay or clay textures are exposed.

2. Seven and a half tons per acre per [year] where silt, silty clay loam or silt loam textures are exposed.

(b) A reduction of at least 80% of the potential sediment load in storm water runoff from the site on an average annual basis as compared with no sediment or erosion controls for the site where the land disturbing construction activity involves one or more acres.

(c) A reduction of at least 40% of the potential sediment load in storm water runoff from the site on an average annual basis as compared with no sediment or erosion controls for the site where less than one acre of land disturbing construction activity is to occur.

*Note:* See appendix for further explanatory material regarding compliance solutions for 80 and 40% reductions.

(4) **SOIL LOSS ANALYSIS.** Potential soil loss shall be determined using an engineer analytical modeling acceptable to the department.

*Note:* The Revised Universal Soil Loss Equation II is an example of an acceptable model to determine soil loss.

(5) **MONITORING.** (a) The owner or owner's agent shall check the erosion and sediment control practices for maintenance needs at all the following intervals until the site is stabilized:

1. At least weekly.

2. Within 24 hours after a rainfall event of 0.5 inches or greater. A rainfall event shall be considered to be the total amount of rainfall recorded in any continuous 24 hour period.

3. At all intervals cited on the erosion and sediment control plan.

(b) The owner or owner's agent shall maintain a monitoring record when the land disturbing construction activity involves one or more acres.

(c) The monitoring record shall contain at least the following information:

1. The condition of the erosion and sediment control practices at the intervals specified under par. (a).

2. A description of the maintenance conducted to repair or replace erosion and sediment control practices.

(6) **MAINTENANCE.** (a) 1. Except as provided in subd. 3., off-site sediment deposition resulting from the failure of an erosion or sediment control practice shall be cleaned up by the end of the next day.

*Note:* Contact the Department of Natural Resources before attempting to clean up any sediment deposited or discharged into the waters of the state.

2. Except as provided in subd. 3., off-site soil deposition, resulting from construction activity, that creates a nuisance shall be cleaned up by the end of the work day.

3. A municipality may enact more stringent requirements regarding cleanup of soil or sediment deposition onto public ways.

(b) 1. Except as required in subd. 2., the owner or owner's agent shall complete repair or replacement of erosion and sediment control practices as necessary within 48 hours of an interval specified under sub. (5).

2. When the failure of erosion or sediment control practices results in an immediate threat of sediment entering public sewers or the waters of the state, procedures shall be implemented immediately to repair or replace the practices.

Note: See Appendix for further explanatory material.

History: Cr. Register, September, 1992, No. 441, eff. 12-1-92; am. (1) (b), Register, November, 1995, No. 479, eff. 12-1-95; am. (1) (a), renum. (1) (b) to (c) to be (1) (c) to (f) and am. (c), cr. (1) (b), Register, February, 1997, No. 494, eff. 3-1-97; CR 02-077; cr. (4) Register May 2003 No. 569, eff. 8-1-03; CR 05-113; r. and rec. Register December 2006 No. 612, eff. 4-1-07.

**Comm 21.126 Storm water management.** Storm water management practices shall be employed in accordance with s. NR 151.12 and maintained when the land disturbing construction activity involves one or more acres.

Note: See appendix for further explanatory material.

History: CR 05-113; cr. Register December 2006 No. 612, eff. 4-1-07.

**Comm 21.13 Excavations adjacent to adjoining property.** (1) NOTICE. Any person making or causing an excavation which may affect the lateral soil support of adjoining property or buildings shall provide at least 30 days written notice to all owners of adjoining buildings of the intention to excavate. The notice shall state that adjoining buildings may require permanent protection.

(a) Exception. The 30-day time limit for written notification may be waived if such waiver is signed by the owner(s) of the adjoining properties.

(2) RESPONSIBILITY FOR UNDERPINNING AND FOUNDATION EXTENSIONS. (a) Excavations less than 12 feet in depth. If the excavation is made to a depth of 12 feet or less below grade, the person making or causing the excavation shall not be responsible for any necessary underpinning or extension of the foundations of any adjoining buildings.

(b) Excavations greater than 12 feet in depth. If the excavation is made to a depth in excess of 12 feet below grade, the owner(s) of adjoining buildings shall be responsible for any necessary underpinning or extension of the foundations of their buildings to a depth of 12 feet below grade. The person making or causing the excavation shall be responsible for any underpinning or extension of foundations below the depth of 12 feet below grade.

History: Cr. Register, November, 1979, No. 287, eff. 6-1-80.

**Comm 21.14 Excavations for footings and foundations.** (1) EXCAVATIONS BELOW FOOTINGS AND FOUNDATIONS. No excavation shall be made below the footing and foundation unless provisions are taken to prevent the collapse of the footing or foundation.

(2) EXCAVATIONS FOR FOOTINGS. All footings shall be located on undisturbed or compacted soil, free of organic material, unless the footings are reinforced to bridge poor soil conditions.

History: Cr. Register, November, 1979, No. 287, eff. 6-1-80.

**Subchapter IV — Footings**

**Comm 21.15 Footings.** (1) GENERAL. (a) The dwelling and attached structures, such as decks and garages, shall be supported on a structural system designed to transmit and safely distribute the loads to the soil.

(b) The loads for determining the footing size shall include the weight of the live load, roof, walls, floors, pier or column, plus the weight of the structural system and the soil over the footing.

(c) Footings shall be sized to not exceed the allowable material stresses.

(d) The bearing area shall be at least equal to the area required to transfer the loads to the supporting soil without exceeding the bearing capacity of the soil.

(e) Structures supported on floating slabs or similar shallow foundations may not be physically attached to structures that are supported by footings that extend below the frost line unless an isolation joint is used between the structures. This isolation shall extend for the full height of the structure.

(2) SIZE AND TYPE. Unless designed by structural analysis, unreinforced concrete footings shall comply with the following requirements:

(a) Continuous footings. The minimum width of the footing on each side of the foundation wall shall measure at least 4 inches wider than the wall. The footing depth shall be at least 8 inches nominal. Footing placed in unstable soil shall be formed. Lintels may be used in place of continuous footings when there is a change in footing elevation.

Note: Unstable soil includes soils that are unable to support themselves at a 90 degree angle for the full depth of the footing.

(b) Column or pier footing. 1. The minimum width and length of column or pier footings shall measure at least 2 feet by 2 feet.

2. The minimum depth of column or pier footings shall measure at least 12 inches nominal.

(c) Trench footings. Footings poured integrally with the wall may be used when soil conditions permit. The minimum width shall be at least 8 inches nominal.

(d) Chimney and fireplace footings. Footing for chimneys or fireplaces shall extend at least 4 inches on each side of the chimney or fireplace. The minimum depth shall measure at least 12 inches nominal.

(e) Floating slabs. Any dwelling supported on a floating slab on grade shall be designed through structural analysis.

(f) Deck footings. Decks attached to dwellings and detached decks which serve an exit shall be supported on a structural system designed to transmit and safely distribute the loads to the soil. Footings shall be sized to not exceed the allowable material stresses. The bearing area shall be at least equal to the area required to transfer the loads to the supporting soil without exceeding the bearing values of the soil.

(3) SOIL-BEARING CAPACITY. No footing or foundation shall be placed on soil with a bearing capacity of less than 2,000 pounds per square foot unless the footing or foundation has been designed through structural analysis. The soil-bearing values of common soils may be determined through soil identification.

Note: The department will accept the soil-bearing values for the types of soil listed in the following table:

Type of soil	PSF
1. Wet, soft clay; very loose silt; silty clay	2,000
2. Loose, fine sand; medium clay; loose sandy clay soils	2,000
3. Stiff clay; firm inorganic silt	3,000
4. Medium (firm) sand; loose sandy gravel; firm sandy clay soils; hard dry clay	4,000
5. Dense sand and gravel; very compact mixture of clay, sand and gravel	6,000
6. Rock	12,000

(a) Minimum soil-bearing values. If the soil located directly under a footing or foundation overlies a layer of soil having a smaller allowable bearing value, the smaller soil-bearing value shall be used.

(b) Unprepared fill material, organic material. No footing or foundation shall be placed upon unprepared fill material, organic soil, alluvial soil or mud unless the load will be supported. When requested, soil data shall be provided.

Note: The decomposition of organic material in landfill sites established for the disposal of organic wastes may produce odorous, toxic and explosive concentrations of gas which may seep into buildings through storm sewers and similar underground utilities unless provisions are taken to release the gases to the atmosphere.

History: Cr. Register, November, 1979, No. 287, eff. 6-1-80; am. (1) (a), Register, January, 1989, No. 397, eff. 2-1-89; cr. (1) (f), Register, March, 1992, No. 435, eff. 4-1-92; am. (1) (e), Register, November, 1995, No. 479, eff. 12-1-95; am. (1) (e), Register, March, 2001, No. 543, eff. 4-1-01; CR 08-043; renum. (intro.), (1) and (2) to be (1), (2) and (3) and am. (1), (2) (b) and (c), cr. (1) (e) Register March 2009 No. 639, eff. 4-1-09.

**Comm 21.16 Frost protection.** (1) GENERAL. (a) Except as allowed under sub. (2), footings and foundations, including those for ramps and stoops, shall be placed below the frost penetration level or at least 48 inches below adjacent grade, whichever is deeper.

(b) Footings may not be placed on frozen material.

(2) EXCEPTIONS. (a) Frost protected shallow foundations shall be designed in accordance with ASCE-32 as adopted in Table Comm 20.24-5.

(b) Portions of footings or foundations located directly under window areaways do not require frost protection provided the rest of the foundation is protected in accordance with this section.

(c) Footings and foundations may bear directly on bedrock less than 48 inches below adjacent grade provided all of the following conditions are met.

1. The rock shall be cleaned of all earth prior to placement.

2. All clay in crevices of the rock shall be removed to the level of frost penetration or to 1.5 times the width of the rock crevice, whichever is less.

3. Provisions shall be taken to prevent water from collecting anywhere along the foundation.

Note: See Appendix for further information.

History: Cr. Register, November, 1979, No. 287, eff. 6-1-80; am. (intro.), Register, February, 1985, No. 350, eff. 3-1-85; renum. (intro.) and (1) to be (1) and (2) and am. (2) (d), cr. (2) (c), Register, January, 1989, No. 397, eff. 2-1-89; am. (1), Register, November, 1995, No. 479, eff. 12-1-95; correction in (2) (c) made under s. 13.93 (2m) (b) 7., Stats., Register, March, 2001, No. 543; CR 08-043: r. and recr. Register March 2009 No. 639, eff. 4-1-09.

### Comm 21.17 Drain tiles. (1) DETERMINATION OF NEED.

(a) *New construction.* 1. Except as provided under sub. (2), a complete drain tile or pipe system shall be installed around the foundation of dwellings under construction where groundwater occurs above the bottom of the footing.

2. For the purposes of this section, a complete drain tile or pipe system includes all of the following:

a. The drain tile or pipe installed inside and outside the foundation, except as allowed under s. Comm 21.17 (3) (d) 1. b.

b. Bleeders connecting the inside tile or pipe to the outside tile or pipe.

c. The sump pit or crock.

d. The discharge piping.

e. A pump or other means of discharging water to grade.

(b) *Optional systems.* 1. If a complete drain tile or pipe system is not required by natural conditions under par. (a) or by a municipality or registered UDC inspection agency, a partial drain tile or pipe system may be installed.

2. For the purposes of this section, a partial drain tile or pipe system includes a means of discharging water from the tile or pipe and may include any of the other elements under par. (a) 2.

Note: Means of discharging water include a sump pit, a crock or natural means of drainage to daylight.

(2) OPTIONAL SYSTEMS. (a) *New construction.* 1. For new dwelling construction, a municipality or registered UDC inspection agency may determine the soil types and natural or seasonal groundwater levels for which a complete drain tile or pipe system is required.

2. For new dwelling construction, a municipality may not enact requirements for other than complete drain tile or pipe systems.

(b) *Alterations to an existing dwelling.* For an alteration to an existing dwelling covered by this code, a municipality may not require a complete drain tile or pipe system.

(c) *Partial systems.* Municipalities may allow partial drain tile or pipe systems for new dwellings under construction or existing dwellings.

(3) MATERIAL AND INSTALLATION REQUIREMENTS FOR REQUIRED SYSTEMS. (a) *General.* Complete drain tile or pipe systems required by natural conditions under sub. (1) (a) or by a municipality or registered UDC inspection agency shall comply with the requirements of this subsection.

(b) *Basement floor slabs.* The basement slab shall be placed on at least 4 inches of clean graded sand, gravel or crushed stone.

(c) *Manufactured drainage systems.* Manufactured drainage systems not meeting the requirements of this section shall be submitted to the department for review and approval prior to installation.

(d) *Drain tile or pipe installation.* Drain tile or pipe used for foundation drainage shall comply with the following requirements:

1. a. Except as allowed under subd. 1. b., the top of the tile or pipe shall be at or below the top of the footing.

b. Where the top of the footing is more than 4 inches below the bottom of the floor slab, tile or pipe is required on the interior of the foundation only and it shall be placed directly under the floor.

Note: This situation will commonly occur with a walk-out basement.

2. Drain tile or pipe shall have an inside diameter of at least 3 inches.

3. Drain tile or pipe shall have open seams, joints or perforations to allow water to enter.

4. Where individual tiles are used, they shall be laid with  $\frac{1}{8}$  inch open joints. Joints between tiles shall be covered with a strip of asphalt or tar impregnated felt.

5. The tile or pipe shall be placed upon at least 2 inches of coarse aggregate and shall be covered on the top and the side facing away from the dwelling with at least 12 inches of coarse aggregate that meets all of the following criteria:

a. 100% of the aggregate shall pass a 1-inch sieve.

b. 90-100% of the aggregate shall pass a  $\frac{3}{4}$ -inch sieve.

c. 0-55% of the aggregate shall pass a  $\frac{3}{8}$ -inch sieve.

d. 0-5% of the aggregate shall pass a #8 sieve.

Note: A #8 sieve has square openings of 2.36 mm or 0.09 inch.

Note: These specifications encompass aggregate sizes #6 and #67 per ASTM standard C 33. Of the two sizes, #6 is coarser.

6. a. Bleeder tiles or pipes shall be provided at no more than 8-foot intervals to connect the exterior drain tile or pipe to the interior drain tile or pipe.

b. Bleeder tiles or pipes shall have a minimum interior diameter of 3 inches.

c. Direct connection of the bleeders is not required if the intersection of the bleeder with the tile or pipe is covered with a membrane or fabric that prevents soil and fines from entering the system.

7. The drain tiles or pipe that lead from the footing tiles to the sump pit shall be laid at a grade of at least  $\frac{1}{8}$  inch per foot leading to the sump pit. The remaining drain tiles or pipe shall be level or graded downward to the line leading to the sump pit.

(e) *Drain tile or pipe discharge.* 1. Drain tiles or pipe shall be connected to the sump pit.

2. The sump pit shall discharge to natural grade or be equipped with a pump.

3. All other aspects of drain tile discharge shall be in accordance with the uniform plumbing code, chs. Comm 82 to 87.

Note: The following is a reprint of a pertinent section of the plumbing code:

**Comm 82.36 (8) SUMPS AND PUMPS.** (a) *Sumps.* 1. 'General.' All storm building subdrains shall discharge into a sump, the contents of which shall be automatically lifted and discharged, dispersed or used in accordance with sub. (4).

2. 'Construction and installation'. a. Except as provided in subd. 2. c. and d., an interior sump shall have a rim extending at least one inch above the floor immediately adjacent to the sump.

b. A sump shall have a removable cover of sufficient strength for anticipated loads.

c. Where a sump is installed in an exterior meter pit or elevator pit, the rim may be level with the floor.

d. When a sump is provided with an airtight, solid cover.

3. 'Location'. All sumps installed for the purpose of receiving clearwater, groundwater or stormwater shall be separated from water wells by the applicable separation distances contained in chs. NR 811 and 812, or as otherwise permitted by the department of natural resources.

Note: See Appendix A-82.30 (11) (d) for material reprinted from s. NR 812.08.

4. 'Size'. Except as recommended by the pump manufacturer, the size of each sump shall be no smaller than 16 inches in diameter at the top, 14 inches in diameter at the bottom, and 22 inches in depth.

(b) *Pumps.* 1. 'Size.' The pump shall be of a capacity appropriate for the anticipated use.

2. 'Discharge piping.' a. Where a pump discharges into a storm drain system, a check valve shall be installed.

b. The minimum diameter discharge piping shall be based on the design flow rate of the pump and a minimum velocity of one foot/second.

History: Cr. Register, November, 1979, No. 287, eff. 6-1-80; r. and recr. Register, February, 1985, No. 350, eff. 3-1-85; r. and recr. (3) (a) 3. and (4), Register, May, 1988, No. 389, eff. 6-1-88; am. (2) (f), Register, January, 1989, No. 397, eff. 2-1-89;

r. and recr. (4) (c) 3., Register, August, 1991, No. 428, eff. 9-1-91; cr. (5), Register, March, 1992, No. 435, eff. 4-1-92; r. and recr. Register, January, 1999, No. 517, eff. 2-1-99; am. (3) (d) 4., Register, March, 2001, No. 543, eff. 4-1-01; CR 03-097; am. (1) (b) 1., (2) (a) 1., and (3) (a) Register November 2004 No. 587, eff. 1-1-05; CR 08-043; am. (1) (a) 2. and (b) 2., renum. (3) (d) 1. to 4., 5. and 6. to be (3) (d) 2. to 5., 6. a. and 7., cr. (3) (d) 1., 6. b. and c. Register March 2009 No. 639, eff. 4-1-09.

### Subchapter V — Foundations

**Comm 21.18 Foundations. (1) GENERAL. (a) Design.** Foundation walls shall be designed and constructed to support the vertical loads of the dwelling, lateral soil pressure, and other loads without exceeding the allowable stresses of the materials of which the foundations are constructed.

(b) *Lateral support at base.* Lateral support such as floor slabs or framing shall be provided at the base of foundation walls.

(c) *Lateral support at top.* Lateral support shall be provided at the top of the foundation walls by one of the following:

2. Structural analysis. A system designed through structural analysis.

3. Anchor bolts. a. Structural steel anchor bolts, at least ½ inch in diameter, embedded at least 7 inches into the [concrete or] grouted masonry with a maximum spacing of 72 inches and located within 18 inches of wall corners.

b. A properly sized nut and washer shall be tightened on each bolt to the plate or sill.

c. When vertical-reinforcing steel is provided in masonry construction, as required under sub. (3), the location requirements under subd. 3. a. shall be modified as necessary so anchor bolts are

placed in the same core as the reinforcement without exceeding the limits of subd. 3. a.

4. Other mechanical fasteners. a. Mechanical fasteners used in accordance with the manufacturer's testing and listing.

b. When vertical-reinforcing steel is provided in masonry construction, as required under sub. (3), the location requirements under subd. 4. a. shall be modified as necessary so the fasteners are placed in the same core as the reinforcement without exceeding the limits of subd. 4. a.

(d) *Floor framing.* 1. Floor framing shall be fastened to the sill plate by one of the following methods:

a. Mechanical fasteners used in accordance with the manufacturer's testing and listing.

b. In accordance with structural analysis.

c. In accordance with the fastener table printed in the appendix to this code.

**Note:** Per s. Comm 21.22 (1), sill plates are not required on foundation walls of poured concrete or on masonry walls with mortar- or grout-filled cores or on masonry walls with a solid block top course.

2. a. Where the floor framing is parallel to the foundation wall, solid blocking or bridging shall be installed in at least the first adjacent joist space at a spacing of no more than 32 inches on center.

b. Blocking and bridging shall be the same depth as the joist.

c. Fastening of the blocking or bridging shall be in accordance with structural analysis or the fastener table printed in the appendix to this code.

(e) *Soil lateral load.* Unless designed through structural analysis, soil lateral loads shall be determined from Table 21.18-A.

TABLE 21.18-A  
SOIL LATERAL LOAD

Description of Backfill Material <sup>e</sup>	Unified Soil Classification	Design Lateral Soil Load <sup>a</sup> PSF per Foot of Depth
Well graded, clean gravels; gravel-sand mixes	GW	30 <sup>c</sup>
Poorly graded clean gravels; gravel-sand mixes	GP	30 <sup>c</sup>
Silty gravels, poorly graded gravel-sand mixes	GM	40 <sup>c</sup>
Clayey gravels, poorly graded gravel-and-clay mixes	GC	45 <sup>c</sup>
Well-graded, clean sands; gravelly sand mixes	SW	30 <sup>c</sup>
Poorly graded clean sands; sand-gravel mixes	SP	30 <sup>c</sup>
Silty sands, poorly graded sand-silt mixes	SM	45 <sup>c</sup>
Sand-silt clay mix with plastic fines	SM-SC	45 <sup>d</sup>
Clayey sands, poorly graded sand-clay mixes	SC	60 <sup>d</sup>
Inorganic silts and clayey silts	ML	45 <sup>d</sup>
Mixture of inorganic silt and clay	ML-CL	60 <sup>d</sup>
Inorganic clays of low to medium plasticity	CL	60 <sup>d</sup>
Organic silts and silt clays, low plasticity	OL	b
Inorganic clayey silts, elastic silts	MH	60 <sup>d</sup>
Inorganic clays of high plasticity	CH	b
Organic clays and silty clays	OH	b

<sup>a</sup>Design lateral soil loads are given for moist conditions for the specified soils at their optimum densities. Actual field conditions shall govern. Submerged or saturated soil pressures shall include the weight of the buoyant soil plus the hydrostatic loads.

<sup>b</sup>Unsuitable as backfill material.

<sup>c</sup>For relatively rigid walls, as when braced by floors, the design lateral soil load shall be increased for sand and gravel type soils to 60 psf per foot of depth. Basement walls extending not more than 8 feet below grade and supporting flexible floor systems are not considered relatively rigid walls.

<sup>d</sup>For relatively rigid walls, as when braced by floors, the design lateral load shall be increased for silt and clay type soils to 100 psf per foot of depth. Basement walls extending not more than 8 feet below grade and supporting flexible floor systems are not considered relatively rigid walls.

<sup>e</sup>Soil classes are in accordance with the Unified Soil Classification System, ASTM D2487, and design lateral loads are for moist soil conditions without hydrostatic pressure.

(2) CONCRETE FOUNDATION WALLS. (a) *General structural requirements.* Except as provided in par. (b), unless designed through structural analysis, the minimum thickness of concrete foundation walls shall be determined from Table 21.18-B, but in no case shall the thickness of the foundation wall be less than the thickness of the wall it supports.

(b) *Equalized loading.* A 6-inch nominal wall thickness may be used provided the fill on one side of the wall is within 12 inches vertically of the fill on the other side of the wall.

Note: See s. Comm 21.15 (1) (c) for trench footing requirements.

TABLE 21.18-B  
CONCRETE WALL THICKNESSES

Type of Concrete	Nominal Thickness (inches)	Maximum Height of Unbalanced Fill <sup>1</sup> for Material of Wall Being Supported (Wood frame — feet)
3000 psi	8	8
Unreinforced concrete	10	9
	12 <sup>2</sup>	10
	14	11.5

<sup>1</sup>Unbalanced fill is the difference in elevation between the outside grade and the basement floor.

<sup>2</sup>The maximum height of unbalanced fill for a 12-inch thick plain concrete wall may be increased to 12 feet provided the wall is constructed of concrete with a minimum compressive value of 6,000 psi at 28 days.

(3) MASONRY FOUNDATION WALLS. (a) *Dampproofing.* 1. Except as allowed under subd. 3., masonry block foundation walls shall be coated with a layer of minimum  $\frac{3}{8}$ -inch thick type M or S portland cement mortar parging on the exterior of the wall from footing to finished grade.

2. Masonry foundation walls shall be damp-proofed by applying to the exterior surface of the portland cement parging from footing to finished grade, a continuous coating of one of the following:

a. A bituminous coating applied in accordance with the manufacturer's instructions.

b. Acrylic-modified cement applied at a minimum rate of 3 pounds per square yard.

c. A layer of minimum  $\frac{1}{8}$ -inch thick structural surface bonding material labeled as complying with ASTM C887.

Note: The ASTM C887 standard is entitled, "Standard Specification for Packaged, Dry, Combined Materials for Surface Bonding Mortar."

d. A waterproofing treatment applied in accordance with the manufacturer's instructions.

3. a. Parging of masonry block foundation walls is not required where a dampproofing material is sufficiently flexible to be listed or designed for direct application to masonry block.

b. Parging of masonry block foundation walls is not required where a layer of minimum  $\frac{1}{4}$ -inch thick structural surface bonding material labeled as complying with ASTM C887 is used for dampproofing.

(b) *Structural requirements.* Unless designed through structural analysis, the masonry foundation walls shall be constructed in accordance with ACI 530.1 and the following requirements:

1. The minimum thickness of unreinforced masonry foundation walls shall be determined by Table 21.18-C, but in no case shall the thickness be less than the thickness of the wall it supports.

**TABLE 21.18-C**  
**PLAIN MASONRY FOUNDATION WALLS<sup>d</sup>**

Maximum Wall Height (ft-in)	Depth of unbalanced backfill height (ft)	Minimum nominal wall thickness (inches)		
		Soil classes and lateral soil load <sup>a</sup> (psf per foot below exterior grade)		
		GW, GP, SW and SP soils 30	GM, GC, SM, SM-SC and ML soils 45	SC, MH, ML-CL and inorganic CL soils 60
7-8	4 (or less)	8	8	8
	5	8	10	10
	6	10	12	10 (solid <sup>b</sup> )
	7	12	10 (solid <sup>b</sup> )	12 (solid <sup>b</sup> )
8-4	4 (or less)	8	8	8
	5	8	10	12
	6	10	12	12 (solid <sup>b</sup> )
	7	12	12 (solid <sup>b</sup> )	Note c
9-1	8	10 (solid <sup>b</sup> )	12 (solid <sup>b</sup> )	Note c
	4 (or less)	8	8	8
	5	8	10	12
	6	12	12	12 (solid <sup>b</sup> )
7	7	12 (solid <sup>b</sup> )	12 (solid <sup>b</sup> )	Note c
	8	12 (solid <sup>b</sup> )	Note c	Note c
	9	Note c	Note c	Note c

<sup>a</sup> For design lateral soils, see s. Comm 21.18 (1) (c). Soil classes are in accordance with the Unified Soil Classification System and design lateral soil loads are for moist soil conditions without hydrostatic pressure.  
<sup>b</sup> Solid grouted hollow units.  
<sup>c</sup> An analysis in compliance with ACI 530 or reinforcement in accordance with Table 21.18-D, 21.18-E or 21.18-F is required.  
<sup>d</sup> Mortar shall be Type M or S and masonry shall be laid in running bond.

2. Reinforced masonry walls shall be reinforced in accordance with the requirements of Tables 21.18-D, 21.18-E or 21.18-F. Vertical reinforcement shall be provided on each side of any opening and at intervals indicated in the appropriate table.

**TABLE 21.18-D<sup>b,c,d</sup>**

**8, 10 OR 12 IN. REINFORCED MASONRY FOUNDATION WALLS**  
**WHERE  $d \geq 5$  in.<sup>e</sup>**

Maximum Wall Height (ft-in)	Height of unbalanced backfill (ft)	Vertical reinforcement		
		Soil classes and lateral soil load <sup>a</sup> (psf per foot below exterior grade)		
		GW, GP, SW and SP soils 30	GM, GC, SM, SM-SC and ML soils 45	SC, MH, ML-CL and inorganic CL soils 60
7-8	4 (or less)	#4 at 48" o.c.	#4 at 48" o.c.	#4 at 48" o.c.
	5	#4 at 48" o.c.	#4 at 48" o.c.	#4 at 40" o.c.
	6	#4 at 48" o.c.	#5 at 48" o.c.	#5 at 40" o.c.
	7	#4 at 40" o.c.	#5 at 40" o.c.	#6 at 48" o.c.
8-4	4 (or less)	#4 at 48" o.c.	#4 at 48" o.c.	#4 at 48" o.c.
	5	#4 at 48" o.c.	#4 at 48" o.c.	#4 at 40" o.c.
	6	#4 at 48" o.c.	#5 at 48" o.c.	#5 at 40" o.c.
	7	#5 at 48" o.c.	#6 at 48" o.c.	#6 at 40" o.c.
9-1	8	#5 at 40" o.c.	#6 at 40" o.c.	#7 at 40" o.c.
	4 (or less)	#4 at 48" o.c.	#4 at 48" o.c.	#4 at 48" o.c.
	5	#4 at 48" o.c.	#4 at 48" o.c.	#5 at 48" o.c.
	6	#4 at 48" o.c.	#5 at 48" o.c.	#6 at 48" o.c.
7	7	#5 at 48" o.c.	#6 at 48" o.c.	#7 at 48" o.c.
	8	#5 at 40" o.c.	#7 at 48" o.c.	#8 at 48" o.c.
	9	#6 at 40" o.c.	#8 at 48" o.c.	#8 at 32" o.c.

<sup>a</sup> For design lateral soil loads, see s. Comm 21.18 (1) (e). Soil classes are in accordance with the Unified Soil Classification System and design lateral soil loads are for moist soil conditions without hydrostatic pressure.  
<sup>b</sup> Provisions for this table are based on construction requirements specified in s. Comm 21.18 (3) (b).  
<sup>c</sup> For alternative reinforcement, see s. Comm 21.18 (3) (b).  
<sup>d</sup> Mortar shall be Type M or S and masonry shall be laid in running bond.  
<sup>e</sup> The specified location of the reinforcement shall equal or exceed the effective depth distance, d, measured from the face of the soil side of the wall to the center of vertical reinforcement.

**TABLE 21.18-E<sup>b,c,d</sup>**  
**10 OR 12 IN. REINFORCED MASONRY FOUNDATION WALLS**  
**WHERE  $d \geq 6.75$  in.<sup>e</sup>**

Maximum Wall Height (ft-in)	Height of unbalanced backfill (ft)	Vertical reinforcement		
		Soil classes and lateral soil load <sup>a</sup> (psf per foot below exterior grade)		
		GW, GP, SW and SP soils 30	GM, GC, SM, SM-SC and ML soils 45	SC, MH, ML-CL and inorganic CL soils 60
7-8	4 (or less)	#4 at 56" o.c.	#4 at 56" o.c.	#4 at 56" o.c.
	5	#4 at 56" o.c.	#4 at 56" o.c.	#4 at 56" o.c.
	6	#4 at 56" o.c.	#4 at 48" o.c.	#4 at 40" o.c.
	7	#4 at 56" o.c.	#5 at 56" o.c.	#5 at 40" o.c.
8-4	4 (or less)	#4 at 56" o.c.	#4 at 56" o.c.	#4 at 56" o.c.
	5	#4 at 56" o.c.	#4 at 56" o.c.	#4 at 48" o.c.
	6	#4 at 56" o.c.	#4 at 48" o.c.	#5 at 56" o.c.
	7	#4 at 48" o.c.	#4 at 32" o.c.	#6 at 56" o.c.
9-1	8	#5 at 56" o.c.	#5 at 40" o.c.	#7 at 56" o.c.
	4 (or less)	#4 at 56" o.c.	#4 at 56" o.c.	#4 at 56" o.c.
	5	#4 at 56" o.c.	#4 at 56" o.c.	#4 at 48" o.c.
	6	#4 at 56" o.c.	#4 at 40" o.c.	#4 at 32" o.c.
7	7	#4 at 40" o.c.	#5 at 48" o.c.	#6 at 48" o.c.
	8	#4 at 32" o.c.	#6 at 48" o.c.	#4 at 16" o.c.
	9	#5 at 40" o.c.	#6 at 40" o.c.	#7 at 40" o.c.

<sup>a</sup> For design lateral soil loads, see s. Comm 21.18 (1) (e). Soil classes are in accordance with the Unified Soil Classification System and design lateral soil loads are for moist soil conditions without hydrostatic pressure.  
<sup>b</sup> Provisions for this table are based on construction requirements specified in s. Comm 21.18 (3) (b).  
<sup>c</sup> For alternative reinforcement, see s. Comm 21.18 (3) (b).  
<sup>d</sup> Mortar shall be Type M or S and masonry shall be laid in running bond.  
<sup>e</sup> The specified location of the reinforcement shall equal or exceed the effective depth distance, d, measured from the face of the soil side of the wall to the center of vertical reinforcement.

**TABLE 21.18-F<sup>b,c,d</sup>**

**12 IN. REINFORCED MASONRY FOUNDATION WALLS WHERE  $d \geq 8.75$  in.<sup>e</sup>**

Maximum Wall Height (ft-in)	Height of unbalanced backfill (ft)	Vertical reinforcement		
		Soil classes and lateral soil load <sup>a</sup> (psf per foot below exterior grade)		
		GW, GP, SW and SP soils 30	GM, GC, SM, SM-SC and ML soils 45	SC, MH, ML-CL and inorganic CL soils 60
7-8	4 (or less)	#4 at 72" o.c.	#4 at 72" o.c.	#4 at 72" o.c.
	5	#4 at 72" o.c.	#4 at 72" o.c.	#4 at 72" o.c.
	6	#4 at 72" o.c.	#4 at 64" o.c.	#4 at 48" o.c.
	7	#4 at 72" o.c.	#4 at 48" o.c.	#5 at 56" o.c.
8-4	4 (or less)	#4 at 72" o.c.	#4 at 72" o.c.	#4 at 72" o.c.
	5	#4 at 72" o.c.	#4 at 72" o.c.	#4 at 72" o.c.
	6	#4 at 72" o.c.	#4 at 56" o.c.	#5 at 72" o.c.
	7	#4 at 72" o.c.	#5 at 64" o.c.	#4 at 32" o.c.
9-1	8	#4 at 48" o.c.	#4 at 32" o.c.	#5 at 40" o.c.
	4 (or less)	#4 at 72" o.c.	#4 at 72" o.c.	#4 at 72" o.c.
	5	#4 at 72" o.c.	#4 at 72" o.c.	#4 at 64" o.c.
	6	#4 at 72" o.c.	#4 at 56" o.c.	#5 at 64" o.c.
7	7	#4 at 56" o.c.	#4 at 40" o.c.	#6 at 64" o.c.
	8	#4 at 40" o.c.	#6 at 64" o.c.	#6 at 48" o.c.
	9	#5 at 56" o.c.	#7 at 72" o.c.	#6 at 40" o.c.

<sup>a</sup> For design lateral soil loads, see s. Comm 21.18 (1) (e). Soil classes are in accordance with the Unified Soil Classification System and design lateral soil loads are for moist soil conditions without hydrostatic pressure.  
<sup>b</sup> Provisions for this table are based on construction requirements specified in s. Comm 21.18 (3) (b).  
<sup>c</sup> For alternative reinforcement, see s. Comm 21.18 (3) (b).  
<sup>d</sup> Mortar shall be Type M or S and masonry shall be laid in running bond.  
<sup>e</sup> The specified location of the reinforcement shall equal or exceed the effective depth distance, d, measured from the face of the soil side of the wall to the center of vertical reinforcement.



3. Vertical reinforcement shall have a minimum yield strength of 60,000 psi.

4. Solid-grouted hollow units or cores containing vertical reinforcement shall be filled with masonry grout that complies with ASTM C 476.

5. In lieu of the reinforcement provisions of Tables 21.18-D, 21.18-E and 21.18-F, alternative reinforcing bar size and spacing having an equivalent cross-sectional area or reinforcement per linear foot of wall is permitted, provided the spacing of the reinforcement does not exceed 72 inches and reinforcing bar size does not exceed No. 11.

6. The depth below grade, wall height and reinforcement spacing may exceed the maximum values indicated in Tables 21.18-D, 21.18-E and 21.18-F only if the design is based on structural analysis.

**(4) WOOD FOUNDATIONS.** Wood foundations shall be designed and constructed in accordance with the standard adopted in Table 20.24-2.

**Note:** The department will accept Permanent Wood Foundations Design and Construction Guide published by the Southern Forest Products Association through the Southern Pine Council, as complying with this standard. The Design and Construction Guide requires a 3.5 inch thick floor slab if a poured concrete floor slab is used.

**History:** Cr. Register, November, 1979, No. 287, eff. 6-1-80; am. (3) (intro), Register, February, 1985, No. 350, eff. 3-1-85; cr. (2) (c) to (e), r. and recr. Tables C and D, r. (3) (a) 2., renum. (3) (a) 1. to be (a), Register, January, 1989, No. 397, eff. 2-1-89; am. (intro.), (2) (b), (3) (b) and Table 21.18-D, cr. Table 21.18, r. (2) (c), renum. (2) (d) and (e) to be (2) (c) and (d), Register, March, 1992, No. 435, eff. 4-1-92; renum. (1) to (3) to be (2) to (4), and am. (3) (b), (4) (intro.) and (b), Table 21.18-A, r. (intro.) and Table 21.18, cr. (1), (3) (e), Register, November, 1995, No. 479, eff. 12-1-95; am. (2), Register, January, 1999, No. 517, eff. 2-1-99; r. and recr. (1) (b), (3), Tables 21.18-C and D, am. (2) (a), r. Table 21.18-B, renum. Table 21.18-A to be Table 21.18-B and cr. (1) (c), (d), Tables 21.18-A, E and F, Register March 2001 No. 543, eff. 4-1-01; CR 02-077: r. (1) (c) 1., renum. (1) (d) to be (1) (e), cr. (1) (d), am. (4) (intro.), (b) and Tables 21.18-A, C and F Register May 2003 No. 569, eff. 8-1-03; CR 08-043: am. (1) (d) 2. b. and Tables 21.18-C to F, cr. (2) (a) (title) and (b) (title), r. and recr. (3) (a) and (4) Register March 2009 No. 639, eff. 4-1-09.

## Subchapter VI — Floors

**Comm 21.19 Floor design.** Floors shall support all dead loads plus the minimum unit live loads as set forth in s. Comm 21.02. The live loads shall be applied to act vertically and uniformly to each square foot of horizontal floor area. Basements shall be provided with wood or concrete or similar type floors that comply with s. Comm 21.20 or 21.205.

**History:** Cr. Register, November, 1979, No. 287, eff. 6-1-80; r. and recr., Register, March, 1992, No. 435, eff. 4-1-92.

**Comm 21.20 Concrete floors.** (1) When concrete floors are provided, the thickness of the concrete shall measure at least 3 inches.

(2) When a concrete floor is placed in clay soils, a 4-inch thick base course shall be placed in the subgrade consisting of clean graded sand, gravel or crushed stone.

(3) When a concrete floor is placed on sand or gravel soils, the base course may be omitted unless drain tile is installed. If drain tile is installed, the requirements of s. Comm 21.17 shall be met.

**History:** Cr. Register, November, 1979, No. 287, eff. 6-1-80; am. Register, January, 1989, No. 397, eff. 2-1-89; r. and recr. Register, January, 1999, No. 517, eff. 2-1-99.

**Comm 21.203 Garage floors.** (1) **MATERIALS.** Garage floors shall be constructed of concrete or other noncombustible materials which are impermeable to petroleum products. Slab-on-grade concrete garage floors shall be at least 4 inches thick and placed over at least 4 inches of granular fill.

**Note:** It is not the intent of sub. (1) to require a concrete floor to be sealed to make it completely impermeable.

(2) **CONFIGURATION.** The floor shall be sloped such that water is removed in accordance with one of the following:

(a) Water drains toward the overhead door or to exterior grade such that no damage will be caused to any structural member or wall covering of the garage or the dwelling.

(b) Water drains into an interior floor drain that complies with the requirements of ch. Comm 82.

**Note:** See s. Comm 82.34 for floor drain requirements.

**History:** Cr. Register, November, 1995, No. 479, eff. 12-1-95; CR 02-077: r. and recr. (2) Register May 2003 No. 569, eff. 8-1-03.

**Comm 21.205 Wood floors in contact with the ground.** Wood floors in contact with the ground shall comply with the requirements under s. Comm 21.18 (4).

**History:** Cr. Register, January, 1989, No. 397, eff. 2-1-89; am. Register, January, 1999, No. 517, eff. 2-1-99; correction made under s. 13.93 (2m) (b) 7., Stats., Register, March, 2001, No. 543; CR 02-077: r. and recr. Register May 2003 No. 569, eff. 8-1-03.

**Comm 21.21 Precast concrete floors.** Precast concrete floors shall be designed through structural analysis, or load tables furnished by the precast product fabricator may be used, provided the load tables were developed using structural analysis or load testing.

**History:** Cr. Register, November, 1979, No. 287, eff. 6-1-80; r. and recr. Register, March, 1992, No. 435, eff. 4-1-92.

**Comm 21.22 Wood frame floors.** Unless designed through structural analysis, wood frame floors shall comply with the following requirements:

(1) **FLOOR JOISTS.** (a) *General.* 1. Floor joists shall comply with the structural requirements and live load determination under s. Comm 21.02.

**Note:** See Appendix for design information.

2. Where the joists of a floor system are parallel to, and located between bearing walls above and below, the joists shall be doubled.

(b) *Floor joists on concrete walls.* Where a sill plate is provided for floor joists on poured concrete, the sill plates shall be fastened to the foundation.

**Note:** Section Comm 21.18 (1) (d) requires the floor joists to also be fastened to the sill plate.

(c) *Floor joists on masonry walls with a solid top course.* Where a sill plate is provided for floor joists on solid block top course masonry, the sill plate shall be fastened to the foundation.

(d) *Floor joists on masonry walls with open top course.* 1. Where the masonry wall has an open top course, a sill plate at least as wide as the foundation wall shall be fastened to the foundation.

2. Where anchor bolts are used on masonry walls with an open top course, the minimum width of an individual piece making up the sill plate shall be at least 5.5 inches.

**Note:** A sill plate can be made of multiple pieces to achieve the full width.

(2) **FLOOR TRUSSES.** Metal plate connected wood floor trusses shall be designed in accordance with the Design Specifications for Metal Plate Connected Parallel Chord Wood Trusses and the National Design Specification for Wood Construction. Truss members shall not be cut, bored or notched.

(3) **GIRDERS AND BEAMS.** (a) Girders and beams shall be selected from Table 21.22-A1 or Table 21.22-A2 or shall be designed through structural analysis.

(b) Wood girders and beams shall be fitted at the post or column. Adjoining ends shall be fastened to each other to transfer horizontal loads across the joint. Beams shall also be fastened to the posts with framing anchors, angle clips, or equivalent.

(c) Where intermediate beams are used, they shall rest on top of the girders; or shall be supported by ledgers or blocks fastened to the sides of the girders; or they may be supported by approved metal hangers into which the ends of the beams shall be fitted.

(d) Lateral restraint for all wood beams shall be provided at all columns using a saddle or other approved connection where the beam meets one of the following conditions:

1. The beam is not restrained at both ends.

2. The beam is more than 11.25 inches deep using actual measurement.

**Note:** A saddle supports the beam on the bottom and allows for the through-connection of fasteners into the side of the beam.

(4) **BEARING AND END CONFIGURATION.** (a) *Sawn lumber.* 1. 'Joists.' Wood joists made of sawn lumber shall meet the following bearing requirements:

a. Wood joists supported on wood or metal shall have a bearing surface of at least 1½-inches measured from the end of the joist.

b. Wood joists supported on masonry or concrete shall have a bearing surface of at least 3 inches measured from the end of the joist.

c. The tail end of a floor joist may not extend past the edge of a beam by more than the depth of the floor joist.

d. Wood floor joists with ends that intersect over a beam shall have the ends overlap at least 3 inches and be securely fastened together with at least two 12d common nails or the ends shall be butt-jointed or face-jointed and fastened with ties, straps, plates or solid blocking.

2. 'Beams and girders.' Beams and girders made of sawn lumber shall have a bearing surface on their supports of at least 3 inches parallel to the beam or girder and be at least as wide as the beam or girder.

(b) *Engineered wood products.* Bearing surface for engineered wood products shall be in accordance with the manufacturer's instructions provided those instructions were developed through structural analysis or product testing and are applicable to the configuration.

(5) NOTCHING AND BORING. Notching and boring of beams or girders is prohibited unless determined through structural analysis.

(a) *Notching of floor joists.* 1. Notches located in the top or bottom of floor joists shall not have a depth exceeding 1/6 the depth of the joist, shall not have a length exceeding 1/3 the joist depth nor be located in the middle 1/3 of the span of the joist.

2. Where floor joists are notched on the ends, the notch shall not exceed 1/4 the depth of the joist. Notches over supports may extend the full bearing width of the support.

(b) *Boring of floor joists.* 1. 'General.' A hole may not be bored in a floor joist within 2 inches of a notch or another hole. In no case shall the distance between adjacent holes be less than the diameter of the larger hole.

2. 'Holes near the edge.' Holes bored in the top or bottom 2 inches of a joist shall follow the limitations for notching under par. (a).

3. 'Other holes.' Holes bored in floor joists that are not within 2 inches of the top or bottom of the joist shall have their diameter limited to 1/3 the depth of the joist.

(c) *Engineered wood products.* Notching or boring of engineered wood products shall be done in accordance with the manufacturer's instructions provided those instructions were developed through structural analysis or product testing.

(6) OVERHANG OF FLOORS. (a) *General.* Except as provided in pars. (b) and (c), a floor joist overhang shall be cantilevered beyond the outer edge of the supporting wall below it by no more than the actual depth of the joist or shall be designed through structural analysis in accordance with s. Comm 21.02 (3).

(b) *Joist overhangs parallel to the main floor framing system.* Joist overhangs that are extensions of, and parallel to, the main floor framing system may extend beyond the depth of the joist without structural analysis provided they meet all of the following conditions:

1. The overhang is cantilevered no more than 2 feet beyond the outer edge of the supporting wall below it.

2. a. The overhang supports a uniform load limited to the weight of the bearing wall and the tributary roof area above it.

b. The tributary length of the roof area, excluding the eave overhang, is no more than 2 feet greater than the actual length of the joist directly below.

c. The eave overhang is no more than 2 feet.

Note: The tributary length is usually half the span of the joist or rafter.

3. The joist overhang does not support any concentrated loads. For the purposes of this subsection, a framed opening in the wall with a rough opening of 4 feet or less shall be considered uniform loading.

4. a. The cantilevered joist is doubled at the supporting wall.

b. The doubled joist length extends inward beyond the inner edge of the supporting wall by the same distance as the cantilever.

c. The added joist member is secured to the main joist as stated in the nailing schedule in the appendix, under the heading for "floor framing, built-up girder and beams, top loaded".

(c) *Joist overhangs perpendicular to the main floor framing system.* Joist overhangs that are perpendicular to the main floor framing system, or lookout joists, may extend beyond the depth of the joist without structural analysis provided they meet all of the following conditions:

1. The joist overhang is cantilevered no more than 2 feet beyond the outer edge of the supporting wall below it.

2. a. A double floor joist is used to support the lookout joist.

b. The double floor joist is located a distance of at least 2 times the cantilever length inward from the outer edge of the supporting wall below.

c. The lookout joists are fastened to the double joist with metal hangers.

3. The joist overhang supports no more than either a non-bearing wall or a wall that supports only a roof which spans no more than the floor overhang cantilever length plus the eave overhang.

(d) All overhangs longer than the depth of the supporting joist that do not meet all of the conditions under par. (b) or (c) shall be designed through structural analysis.

(7) FLOOR OPENINGS. Trimmers and headers shall be doubled when the span of the header exceeds 4 feet. Headers which span more than 6 feet shall have the ends supported by joist hangers or framing anchors, unless the ends are supported on a partition or beam. Tail joists (joists which frame into headers) more than 8 feet long shall be supported on metal framing anchors or on ledger strips of at least 2 inches by 2 inches nominal.

TABLE 21.22-A1  
MINIMUM SIZES FOR BEAMS AND GIRDERS OF STEEL OR WOOD

Column Spacing	One Floor Only				Roof/Ceiling and One Floor				Roof/Ceiling+ One Floor/Ceiling + One Floor				
	Wood Beams <sup>1</sup> (in., nominal)		A 36 Steel Beams <sup>2</sup>		Wood Beams <sup>1,3</sup> (in., nominal)		A 36 Steel Beams <sup>2</sup>		Wood Beams <sup>1,3</sup> (in., nominal)		A 36 Steel Beams <sup>2</sup>		
	Zone 1	Zone 2	Zone 1	Zone 2	Zone 1	Zone 2	Zone 1	Zone 2	Zone 1	Zone 2	Zone 1	Zone 2	
24 ft. wide house:													
8 ft.	8x8	10x10	8x10	—	—	—	—	—	—	—	—	—	—
10 ft.	8x10	6x12	8x12	—	—	—	—	—	—	—	—	—	—
12 ft.	8x12	8x14	10x14	—	—	—	—	—	—	—	—	—	—
15 ft.	12x12	10x14	8x16	—	—	—	—	—	—	—	—	—	—
26 ft. wide house:													
8 ft.	6x10	10x10	8x12	—	—	—	—	—	—	—	—	—	—
10 ft.	10x10	8x12	10x12	—	—	—	—	—	—	—	—	—	—
12 ft.	8x12	10x14	8x16	—	—	—	—	—	—	—	—	—	—
15 ft.	10x14	8x16	—	—	—	—	—	—	—	—	—	—	—
28 ft. wide house:													
8 ft.	6x10	10x10	8x12	—	—	—	—	—	—	—	—	—	—
10 ft.	10x10	8x12	10x12	—	—	—	—	—	—	—	—	—	—
12 ft.	10x12	8x14	10x14	—	—	—	—	—	—	—	—	—	—
15 ft.	10x14	8x16	—	—	—	—	—	—	—	—	—	—	—
30 ft. wide house:													
8 ft.	8x10	10x10	8x12	—	—	—	—	—	—	—	—	—	—
10 ft.	10x10	8x12	10x12	—	—	—	—	—	—	—	—	—	—
12 ft.	10x12	8x14	10x14	—	—	—	—	—	—	—	—	—	—
15 ft.	12x14	10x16	8x16	—	—	—	—	—	—	—	—	—	—
32 ft. wide house:													
8 ft.	8x10	10x10	8x12	—	—	—	—	—	—	—	—	—	—
10 ft.	10x10	8x12	10x12	—	—	—	—	—	—	—	—	—	—
12 ft.	10x12	8x14	10x14	—	—	—	—	—	—	—	—	—	—
15 ft.	12x14	10x16	8x16	—	—	—	—	—	—	—	—	—	—

<sup>1</sup>This table is based upon wood with a fiber bending stress of 1,000 psi. Two acceptable wood beam selections are listed for each loading condition.

<sup>2</sup>Two acceptable steel beam selections are listed for each loading condition. The first entry is the most economical selection based upon beam weight.

<sup>3</sup>Wood main beams or girders may be built up from nominal 2-inch members. The 2-inch members shall be laid on edge and fastened together with a double row of common nails not less than 3/4-inch in length. Nails shall be spaced not more than 18 inches apart in each row with the end nails placed 4 inches to 6 inches from the end of each piece. Where built-up beams are employed over a single span, the length of each individual piece used to fabricate the beam shall equal the length of the beam.

TABLE 21.22-A2  
MINIMUM SIZES FOR BUILT-UP WOOD BEAMS IN BASEMENTS AND CRAWL SPACES SUPPORTING ONE FLOOR ONLY

HOUSE WIDTH	F <sub>b</sub> =800 psi		F <sub>b</sub> =1000 psi		F <sub>b</sub> =1200 psi		F <sub>b</sub> =1400 psi		
	Col. Spacing ft-in	Beam size	Col. Spacing ft-in	Beam size	Col. Spacing ft-in	Beam size	Col. Spacing ft-in	Beam size	
16 ft.	7-8	3-2x8	8-7	3-2x8	9-4	3-2x8	10-2	3-2x8	
	8-11	4-2x8	9-11	4-2x8	10-11	4-2x8	11-10	4-2x8	
	9-11	3-2x10	11-1	3-2x10	12-1	3-2x10	13-1	3-2x10	
	11-4	4-2x10	12-8	4-2x10	13-1	4-2x10	15-0	4-2x10	
	12-0	3-2x12	13-5	3-2x12	14-8	3-2x12	15-10	3-2x12	
	13-10	4-2x12	15-7	4-2x12	17-0	4-2x12	18-4	4-2x12	
	20 ft.	6-11	3-2x8	7-8	3-2x8	8-5	3-2x8	9-1	3-2x8
		7-11	4-2x8	8-11	4-2x8	9-9	4-2x8	10-7	4-2x8
		8-10	3-2x10	9-11	3-2x10	10-10	3-2x10	11-8	3-2x10
		10-2	4-2x10	11-4	4-2x10	12-6	4-2x10	13-6	4-2x10
		10-9	3-2x12	12-0	3-2x12	13-2	3-2x12	14-3	3-2x12
		11-5	4-2x12	13-11	4-2x12	15-2	4-2x12	16-5	4-2x12
		24 ft.	6-3	3-2x8	7-1	3-2x8	7-8	3-2x8	8-4
7-3			4-2x8	8-2	4-2x8	8-11	4-2x8	9-8	4-2x8
8-1			3-2x10	9-0	3-2x10	9-11	3-2x10	10-8	3-2x10
9-4			4-2x10	10-4	4-2x10	11-5	4-2x10	12-4	4-2x10
9-9			3-2x12	10-11	3-2x12	12-0	3-2x12	12-11	3-2x12
11-3			4-2x12	12-7	4-2x12	13-11	4-2x12	15-0	4-2x12
28 ft.			5-10	3-2x8	6-6	3-2x8	7-2	3-2x8	7-8
	6-8		4-2x8	7-6	4-2x8	8-3	4-2x8	8-11	4-2x8
	7-5		3-2x10	8-4	3-2x10	9-1	3-2x10	9-11	3-2x10
	8-7		4-2x10	9-8	4-2x10	10-6	4-2x10	11-4	4-2x10
	9-0		3-2x12	10-1	3-2x12	11-1	3-2x12	10-11	3-2x12
	10-5		4-2x12	11-8	4-2x12	12-10	4-2x12	13-10	4-2x12
	32 ft.		5-4	3-2x8	6-1	3-2x8	6-8	3-2x8	7-3
		6-3	4-2x8	7-1	4-2x8	7-8	4-2x8	8-4	4-2x8
		7-0	3-2x10	7-9	3-2x10	8-7	3-2x10	9-2	3-2x10
		8-1	4-2x10	8-11	4-2x10	9-10	4-2x10	10-8	4-2x10
		8-5	3-2x12	9-6	3-2x12	10-4	3-2x12	11-1	3-2x12
		9-9	4-2x12	11-0	4-2x12	12-0	4-2x12	12-11	4-2x12
		36 ft.	5-1	3-2x8	5-9	3-2x8	6-3	3-2x8	6-9
5-11			4-2x8	6-7	4-2x8	6-9	4-2x8	7-10	4-2x8
6-6			3-2x10	7-4	3-2x10	8-1	3-2x10	8-8	3-2x10
7-6			4-2x10	8-6	4-2x10	9-4	4-2x10	10-0	4-2x10
7-11			3-2x12	8-11	3-2x12	9-9	3-2x12	10-7	3-2x12
9-2			4-2x12	10-4	4-2x12	11-4	4-2x12	12-4	4-2x12

<sup>1</sup>This table provides maximum allowable spans in feet and inches for main beams or girders which are built-up from nominal 2-inch members.

<sup>2</sup>Fiber bending stress for various species and grades of wood is given in Appendix A2.1.

<sup>3</sup>The 2-inch members shall be laid on edge and fastened together with a double row of common nails not less than 3½-inches in length. Nails shall be spaced not more than 18 inches apart in each row with the end nails placed 4 inches to 6 inches from the end of each piece.

<sup>4</sup>Where built-up wood beams are employed over a single span, the length of each individual piece used to fabricate the beam shall equal the length of the beam.

<sup>5</sup>Where built-up wood beams are continued over more than one span and where lengths of individual pieces are less than the total length of the complete beam, butt joints shall be located over supports or within 6 inches of the quarter points of the clear span. Where located near the quarter points, the joints in built-up beams shall be separated by at least one lamination and shall not exceed the beam width.

(8) FLOOR SHEATHING, BOARDS AND PLANKS. (a) *Plywood sheathing.* Plywood sheathing used for floors shall be limited to the allowable loads and spans shown in Table 21.22-B.

(c) *Combination subfloor-underlayment.* Combination subfloor-underlayment shall be installed in accordance with Table 21.22-D.

(d) *Floor boards.* Where wood boards are used for floor sheathing, the boards shall comply with the minimum thicknesses shown in Table 21.22-E.

(c) *Planks.* Planks shall be tongue and groove or splined and at least 2 inches, nominal, in thickness. Planks shall terminate over beams unless the joints are end matched. The planks shall be laid so that no continuous line of joints will occur except at points of support. Planks shall be nailed to each beam.

(9) BRIDGING. (a) *Sawn lumber.* Bridging shall be provided for sawn lumber framing at intervals not exceeding 8 feet where the nominal depth to thickness ratio is greater than 4 to 1.

(b) *Engineered products.* Bridging shall be provided for engineered framing products in accordance with the manufacturer's recommendations.

**TABLE 21.22-B**  
ALLOWABLE SPANS FOR PLYWOOD FLOOR SHEATHING CONTINUOUS OVER TWO OR MORE SPANS AND FACE GRAIN PERPENDICULAR TO SUPPORTS<sup>1</sup>

Span Rating <sup>2</sup>	Plywood Thickness (in inches)	Maximum span <sup>3</sup> (in inches)
32/16	15/32, 1/2, 5/8	16 <sup>5</sup>
40/20	19/32, 5/8, 3/4, 7/8	20 <sup>4,5</sup>
48/24	23/32, 3/4, 7/8	24

<sup>1</sup>These values apply to C-D, C-C, and Structural I and II grades only. Spans shall be limited to values shown because of possible effect of concentrated loads.

<sup>2</sup>Span Rating appears on all panels in the construction grades listed in footnote 1.

<sup>3</sup>Plywood edges shall have approved tongue and groove joints or shall be supported with blocking, unless 3/4-inch minimum thickness underlayment or 1 1/2 inches of approved cellular or lightweight concrete is installed or finished floor is 25/32-inch wood strip. Allowable uniform load based on deflection of 1/360 of span is 165 pounds per square foot.

<sup>4</sup>For joists spaced 24 inches on center, plywood sheathing with Span Rating 40/20 or greater can be used for subfloors when supporting 1 1/2 inches lightweight concrete.

<sup>5</sup>May be 24 inches if 25/32-inch wood strip flooring is installed at right angles to joists.

**TABLE 21.22-D**  
MINIMUM THICKNESS FOR PLYWOOD COMBINATION SUBFLOOR-UNDERLAYMENT, PLYWOOD CONTINUOUS OVER TWO OR MORE SPANS AND FACE GRAIN PERPENDICULAR TO SUPPORTS<sup>1,2</sup>

Plywood Grade	Plywood Species Group	Maximum Support Spacing <sup>3</sup>		
		16" o.c.	20" o.c.	24" o.c.
Sanded exterior type	1	1/2	5/8	3/4
	2 & 3	5/8	3/4	7/8
	4	3/4	7/8	1
Underlayment C-C Plugged Sturd-I-Floor <sup>4</sup>	All Groups	APA Rated Sheathing and APA Rated Sturd-I-Floor shall be installed consistent with their rating.		

<sup>1</sup>Spans shall be limited to values shown, based on possible effect of concentrated loads.

<sup>2</sup>Unsupported edges shall be tongue and groove or blocked except where 3/4-inch underlayment or 25/32-inch finish floor is used.

<sup>3</sup>Underlayment, C-C Plugged, sanded exterior type: allowable uniform load based on deflection of L/360 span for spans 24 inches or less is 125 psf; and for spans 48 inches, 65 psf.

<sup>4</sup>The department will accept subfloor underlayment panels such as Sturd-I-Floor which meet the requirements of APA manufacturing specifications for Sturd-I-Floor panels.

**TABLE 21.22-E**  
MINIMUM THICKNESS OF FLOOR BOARDS

Joist Spacing (inches)	Minimum Net Thickness (inches)	
	Perpendicular to Joist	Diagonal to Joist
24	11/16	3/4
16	5/8	5/8

**History:** Cr. Register, November, 1979, No. 287, eff. 6-1-80; am. (1) and cr. (1m), Register, February, 1985, No. 350, eff. 3-1-85; renum. (8) (c) and (d) to be (8) (d) and (c) and am. (8) (d), renum. Table 21.22-A and D to be Table 21.22 A1 and E, cr. (8) (c), Table 21.22 A2, r. and recr. Tables 21.22 B and C, Register, January, 1989, No. 397, eff. 2-1-89; am. (2), (4), (5), (6) and (9), r. and recr. Table 21.22-A2, Register, March, 1992, No. 435, eff. 4-1-92; am. (5) (b) and cr. (5) (c), Table 21.22-A1, r. Table 21.22-A, Register, November, 1995, No. 479, eff. 12-1-95; r. and recr. (9), Register, January, 1999, No. 517, eff. 2-1-99; r. and recr. (1m), (4), and (5) (b), Register, March, 2001, No. 543, eff. 4-1-01; CR 02-077: am. (5) (b) 1., r. and recr. (6) Register May 2003 No. 569, eff. 8-1-03; CR 08-043: r. and recr. (1), r. (1m), (8) (b) and Table 21.22-C, renum. (3) (intro.), (a) and (b) to be (3) (a), (b) and (c), cr. (3) (d) Register March 2009 No. 639, eff. 4-1-09.

**Comm 21.225 Decks.** Decks attached to dwellings and detached decks which serve an exit shall comply with the applicable provisions of this chapter, including but not limited to:

- (1) Excavation requirements of s. Comm 21.14;
- (2) Footing requirements of s. Comm 21.15 (2) (f);
- (3) Frost penetration requirements of s. Comm 21.16;
- (4) Load requirements of s. Comm 21.02;
- (5) Stair, handrail and guardrail requirements of s. Comm 21.04; and
- (6) Decay protection requirements of s. Comm 21.10.

**History:** Cr. Register, March, 1992, No. 435, eff. 4-1-92.

**Subchapter VII — Walls**

**Comm 21.23 Wall design.** (1) **LIVE AND DEAD LOADS.** All walls shall support all superimposed vertical dead loads and live loads from floors and roofs.

(2) **HORIZONTAL WIND LOAD.** Walls shall be designed to withstand a horizontal wind pressure of at least 20 pounds per square foot applied to the vertical projection of that portion of the dwelling above grade. No wind load reduction shall be permitted for the shielding effect of other buildings.

**History:** Cr. Register, November, 1979, No. 287, eff. 6-1-80.

**Comm 21.24 Exterior covering.** (1) **GENERAL.** The exterior walls shall be covered with a permanent weather resistant finish.

(2) **DURING CONSTRUCTION.** During construction, wall cavity insulation may not be installed until a water-resistant covering is in place over the wall cavity and windows, doors and a roof with at least underlayment are installed.

**Note:** An example of acceptable water-resistant covering for a wall is foam sheathing with permanently taped joints.

(3) **FLASHING.** (a) Corrosion-resistant flashing shall be installed in the exterior wall to prevent water from entering the wall cavity or coming in contact with the structural framing components.

(b) The flashing shall extend to the surface of the exterior wall finish and prevent water from reentering the exterior wall.

(c) 1. Any joints between 2 pieces of flashing that form a vertical joint shall be lapped a minimum of 6 inches and sealed.

2. Any joints between 2 pieces of flashing that form a horizontal joint shall be lapped a minimum of 2 inches and sealed unless otherwise specified by the flashing manufacturer.

3. Sealants used for flashing shall be exterior grade and shall be compatible with the materials being sealed.

(d) Flashing shall be provided at all of the following locations:

1. At the top of all exterior door and window openings, unless using self-flashing windows that provide at least one inch of flashing around the opening, including the corners.

2. At the intersection of chimneys or other masonry construction with frame walls.
3. Under and at the ends of masonry, wood or metal copings and sills.
4. Continuously above all projecting wood trim.
5. Where porches, decks or stairs attach to a wall or floor assembly of wood frame construction.
6. At wall and roof intersections.
7. At built-in gutters.

**Note:** See s. Comm 21.26 (5) for additional flashing requirements with masonry cavity walls and s. Comm 21.28 (7) for additional flashing requirements with roofing.

**(4) WATER-RESISTIVE BARRIER REQUIREMENTS. (a) General.**

1. Exterior walls of wood or metal frame construction shall be provided with a water-resistive barrier from the highest point to the bottom of the permanent weather-resistant covering.

**Note:** Acceptable water-resistive barrier materials include polymeric-based house wraps and spray-applied water-resistive barriers installed per the manufacturer's instructions, #15 or greater asphalt-saturated felts that comply with ASTM D 226 for type I felt and extruded foam sheathing with permanently taped joints. Duct tape or similar will not result in a permanently taped joint.

2. Structural products with an integral water-resistive barrier may be approved by the department as a complete assembly.

(b) *Material compatibility.* The water-resistive barrier material shall be compatible with the other materials in the wall with which it will come into contact.

**Note:** Spray-applied water-resistive barriers may not be compatible with foam plastic insulation.

(c) *Performance requirements.* 1. Polymer-based house wraps shall meet all of the following requirements:

a. A water vapor permeability rating of 5 perms or higher when tested in accordance with ASTM E96.

b. An acceptable water-resistance rating determined in accordance with ASTM D779, AATCC 127 or CCMC 07102.

**Note:** Asphalt-saturated felt or "tar paper" is not a polymeric-based house wrap.

**Note:** For more information on the water-resistance tests and their results, see the International Code Council Evaluation Services Acceptance Criteria AC 38.

2. Spray-applied water-resistive barriers shall be approved under the International Code Council Evaluation Services.

**Note:** For approval criteria, see ICC-ES acceptance criteria AC 212 or successor document.

(d) *Application.* 1. Horizontal seams in sheet or strip material shall be overlapped such that the upper layer extends over the lower layer at least 2 inches.

2. Vertical seams in sheet or strip materials shall be overlapped at least 6 inches.

3. Any rips, tears or voids shall be patched in accordance with subds. 1. and 2.

(e) *Penetrations.* 1. Penetrations caused by fasteners of the water-resistive barrier or the weather-resistant exterior covering do not require sealing.

2. Penetrations of 5 square inches or less with an annular space of no more than 1/2 inch shall be sealed with caulk or similar material.

3. Penetrations of greater than 5 square inches shall be flashed in accordance with sub. (3).

**History:** Cr. Register, November, 1979, No. 287, eff. 6-1-80; r. and recr. Register, March, 2001, No. 543, eff. 4-1-01; CR 02-077: cr. (3) Register May 2003 No. 569, eff. 8-1-03; CR 08-043: am. (2), renun. (3) (c) to be (3) (d), cr. (3) (c) and (4) Register March 2009 No. 639, eff. 4-1-09.

**Comm 21.25 Wood frame walls.** Unless designed through structural analysis, wood frame walls shall comply with the following requirements.

**(1) STUD CONFIGURATION.** Wood studs shall comply with the size and spacing requirements indicated in Table 21.25-A. Studs in the exterior walls shall be placed with the wide faces perpendicular to the plane of the wall.

**Note:** See Appendix for acceptable nailing schedule.

**Note:** See s. Comm 21.10 for requirements on treating wood for decay and termite resistance.

**(2) TOP PLATES. (a) General.** Except as allowed under subd. 3., top plates shall be provided and configured as follows:

1. Studs at bearing walls shall be capped with double top plates.

2. End joints in double top plates shall be offset at least 2 stud spaces.

3. Double top plates shall be overlapped at the corners and at intersections of partitions.

4. The plate immediately above the stud may have a joint only when directly over the stud.

(b) *Notching and boring.* 1. When piping or ductwork is placed in an exterior wall or an interior load-bearing wall, such that at least half of the top plate is removed, the plate shall be reinforced with a steel angle at least 2 inches by 2 inches by 20 gauge thick.

**Note:** 20 gauge is approximately 0.036 inch.

2. The steel angle shall span the gap and extend at least to the midpoint of the adjacent stud spaces.

3. Other equivalent materials may be used in accordance with s. Comm 21.02.

(c) *Exceptions.* 1. A single top plate may be used in place of a double top plate provided a rafter is located directly over the studs and the plate is securely tied at the end joints, corners and intersecting walls. Joints may occur in single top plates only when directly over a stud.

2. A continuous header, consisting of two 2-inch members set on edge, may be used in lieu of a double plate if tied to the adjacent wall.

**(3) WALL OPENINGS.** Where doors or windows occur, headers shall be used to carry the load across the opening.

(a) *Header size.* The size of headers shall be determined in accordance with the spans and loading conditions listed in Tables 21.25-B, 21.25-C and 21.25-D. Headers for longer spans shall be designed by an engineering method under s. Comm 21.02.

(b) *Header support.* Headers in bearing walls shall be supported in accordance with subd. 1. or 2. or 3.

1. Headers 3 feet or less in length shall be directly supported on each end by either:

- a. The single common stud and a shoulder stud; or
- b. The single common stud with a framing anchor attached.

2. Headers greater than 3 feet but less than or equal to 6 feet in length shall be directly supported on each end by the single common stud and a shoulder stud.

3. Headers greater than 6 feet in length shall be directly supported on each end by the single common stud and 2 shoulder studs.

**(4) NOTCHING.** Notching and boring of columns or posts is prohibited unless designed through structural analysis. Studs shall not be cut or bored more than 1/3 the depth of the stud, unless the stud is reinforced.

**(5) PARTITIONS.** Load-bearing partitions shall be placed over beams, girders, or other load-bearing partitions. Load-bearing partitions running at right angles to the joists shall not be offset from the main girder or walls more than the depth of the joist unless the joists are designed to carry the load.

**(6) POSTS AND COLUMNS. (a) General.** 1. Posts and columns shall be installed to resist imposed loads.

2. Posts and columns shall bear directly over the middle 1/3 of a footing.

3. Posts and columns shall be restrained at the top and bottom to resist displacement.

4. All columns shall be positively attached to the beams they support using clips, straps or saddles.

5. Posts and columns that use a height adjustment mechanism shall have the mechanism imbedded in concrete or permanently disabled after installation.

(b) *Bearing surface.* Posts and columns shall have a steel bearing plate affixed to one or both ends to distribute any applied loads and to prevent fiber crushing of any structural member being supported.

(c) *Steel posts or columns.* Steel posts or columns shall be sized according to one of the following methods:

1. Manufactured columns shall follow the manufacturer's testing and listing.
2. Columns made solely of steel pipe stock shall follow Table

21.25-E.

3. Columns made of steel stock, not meeting the requirements of subd. 1. or 2., shall follow a nationally accepted design specification or the size shall be determined through structural analysis or load testing.

(d) *Wood posts or columns.* Wood posts or columns shall be sized according to Table 21.25-F or the size shall be determined through structural analysis or load testing.

**TABLE 21.25-A**  
SIZE, HEIGHT AND SPACING OF WOOD STUDS<sup>a</sup>

Stud Size (inches)	Bearing Walls					Nonbearing Walls	
	Laterally unsupported stud height <sup>a</sup> (feet)	Maximum spacing when supporting roof and ceiling only (inches)	Maximum spacing when supporting one floor, roof and ceiling (inches)	Maximum spacing when supporting two floors, roof and ceiling (inches)	Maximum spacing when supporting one floor only (inches)	Laterally unsupported stud height <sup>a</sup> (feet)	Maximum spacing (inches)
2 x 3 <sup>b</sup>	-	-	-	-	-	10	16
2 x 4	10	24	16	-	24	14	24
3 x 4	10	24	24	16	24	14	24
2 x 5	10	24	24	-	24	16	24
2 x 6	10	24	24	16	24	20	24

<sup>a</sup> Listed heights are distances between points of lateral support placed perpendicular to the plane of the wall. Increases in unsupported height are permitted where justified by analysis. Studs shall be stud grade or better, except that utility grade may be used when spaced not more than 16 inches on center, supports no more than a roof and ceiling and does not exceed 8 feet in height for exterior walls or 10 feet in height for interior nonload-bearing walls.

<sup>b</sup> May not be used in exterior walls.

Note: A 3-story frame house with walls constructed of 2 x 4 standard grade studs would require a 12-inch stud spacing on the lowest level, a 24-inch stud spacing on the intermediate level, and a 24-inch stud spacing on the upper level.

**TABLE 21.25-B**  
ALLOWABLE SPANS (FEET) FOR HEADERS SUPPORTING ROOF/CEILING ASSEMBLIES\*

House Width (feet)	Header Members									
	Two 2 x 4s		Two 2 x 6s		Two 2 x 8s		Two 2 x 10s		Two 2 x 12s	
	Zone 2/Zone 1		Zone 2/Zone 1		Zone 2/Zone 1		Zone 2/Zone 1		Zone 2/Zone 1	
24	2.5	2.5	4	4	5	5	7	6	9	8
26	2.5	2	4	3	5	5	7	6	8	7
28	2.5	2	4	3	5	4	6	6	8	7
30	2.5	2	4	3	5	4	6	6	8	7
32	2	2	3	3	5	4	6	5	7	7

**TABLE 21.25-C**  
ALLOWABLE SPANS (FEET) FOR HEADERS SUPPORTING ONE FLOOR\*

House Width (feet)	Header Members				
	Two 2 x 4s	Two 2 x 6s	Two 2 x 8s	Two 2 x 10s	Two 2 x 12s
24	2.5	4	5	6	8
26	2.5	3	5	6	8
28	2	3	5	6	7
30	2	3	4	6	7
32	2	3	4	5	7

**TABLE 21.25-D**  
ALLOWABLE SPANS (FEET) FOR HEADERS SUPPORTING ONE FLOOR AND ROOF/CEILING ASSEMBLY\*

House Width (feet)	Header Members									
	Two 2 x 4s		Two 2 x 6s		Two 2 x 8s		Two 2 x 10s		Two 2 x 12s	
	Zone 2/Zone 1		Zone 2/Zone 1		Zone 2/Zone 1		Zone 2/Zone 1		Zone 2/Zone 1	
24	1.5	1.5	3	2.5	4	3	5	4	6	5
26	1.5	1.5	2.5	2.5	3	3	4	4	5	5
28	1.5	1.5	2.5	2.5	3	3	4	4	5	5
30	1.5	1.5	2.5	2.5	3	3	4	4	5	5
32	1.5	1.5	2.5	2	3	3	4	4	5	5

\*These tables are based on wood with a fiber bending stress of 1,000 psi. For other species with different fiber bending stresses, multiply the span by the square root of the ratio of the actual bending stress to 1,000 psi. Example: From Table 21.25-B, the allowable roof/ceiling span for a 28-foot wide house in zone 2, using two 2 x 8 header members with a 1400 psi bending stress, is 5 feet  $\times \sqrt{1400/1000} = 5.9$  feet.

**TABLE 21.25-E**  
COLUMNS MADE OF STEEL PIPE STOCK<sup>1,2</sup>

Column Diameter (inches)	Wall Thickness (inches)	Weight/ft (pounds)	Height (feet)	Allowable Load (pounds)
3	0.216	7.58	8	34,000
			10	28,000
			12	22,000
3.5	0.226	9.11	8	44,000
			10	38,000
			12	32,000
4	0.237	10.79	8	54,000
			10	49,000
			12	43,000
5	0.258	14.62	8	78,000
			10	73,000
			12	68,000
6	0.280	18.97	8	106,000
			10	101,000
			12	95,000

<sup>1</sup>This Table is based on a yield strength or F<sub>y</sub> of 36,000 psi.

<sup>2</sup>This table is for columns made solely of steel pipe stock. The addition of any adjustment mechanism or other feature will alter the load-carrying capacity of the column.

**TABLE 21.25-F**  
WOOD COLUMNS

Wood Nominal Size (inches)	Cross Section Area (inches)	Height (feet)	Allowable Load (pounds)
4 x 4	12.25	8	4,900
		10	3,100
		12	2,150
4 x 6	19.25	8	7,700
		10	4,900
		12	3,400
6 x 6	30.25	8	30,000
		10	18,900
		12	13,300

**Note:** This Table is based on a modulus of elasticity or E of 1,000,000 psi and a fiber bending strength or F<sub>b</sub> of 1,000 psi.

**(7) FOUNDATION CRIPPLE WALLS.** (a) Foundation cripple walls shall be framed with studs at least as large as the studs above.

(b) When more than 4 feet in height, cripple walls shall be framed with studs needed for an additional floor level.

(c) Cripple walls with a stud height of less than 14 inches shall be sheathed on at least one side for its entire length with a wood structural panel that is fastened to both the top and bottom plates or the cripple walls shall be constructed of solid blocking.

(d) Cripple walls with a stud height of 14 inches or greater shall be braced in accordance with sub. (8) or (9).

(e) Cripple walls shall be fully supported by a continuous foundation.

**(8) WALL BRACING.** (a) *General.* Dwellings using wood-framed walls shall be braced in accordance with this section. Where a building, or a portion thereof, does not comply with one or more of the bracing requirements in this section, those portions shall be designed and constructed in accordance with accepted engineering practice.

**Note:** Acceptable engineering wall bracing practices include the provisions under s. R602.10 of the International Residential Code-2009.

(b) *Bracing Materials and Methods.* Braced wall lines, both interior and exterior shall be braced using one of the following materials and methods:

1. a. Nominal 1-inch-by-4-inch continuous diagonal braces let in to the top and bottom plates.

b. The let-in bracing shall be placed at an angle not more than 60 degrees or less than 45 degrees from the horizontal.

2. a. Preformed metal continuous diagonal T-bracing not less than 22 gage thick and 1¼ inch wide let in to the top and bottom plates and the intervening studs installed in accordance with the manufacturer's specifications.

b. The let-in bracing shall be placed at an angle not more than 60 degrees or less than 45 degrees from the horizontal.

**Note:** 22 gage steel is 0.03 inches thick.

3. Wood boards of 5/8-inch net minimum thickness applied diagonally on studs spaced a maximum of 24 inches fastened to studs in accordance with the fastener table in the appendix.

4. Wood structural panel sheathing with all edges fastened to framing or blocking in accordance with the fastener table in the appendix and not less than 3/8 inch thick for 16-inch stud spacing and not less than 7/16 inch thick for 24-inch stud spacing.

5. Minimum ½-inch thick structural fiberboard sheathing applied vertically or horizontally on studs spaced a maximum of 16 inches on center. Structural fiberboard sheathing shall be installed in accordance with the fastener table in the appendix.

6. Gypsum board with minimum ½-inch thickness placed on studs spaced a maximum of 24 inches on center and fastened at panel edges including top and bottom plates at 7 inches on center with the size nails specified in the fastener table in the appendix.

7. Alternative methods under sub. (9), including Alternate Braced Wall Panels, sub. (9) (b), and Continuously Sheathed Braced Wall Lines using Wood Structural Panels, sub. (9) (c).

8. Other approved wind bracing materials and methods.

**Note:** See Appendix for acceptable nailing schedule.

(c) *Minimum length of braced panels.* 1. 'General.' Except as provided under subd. 2., the minimum lengths shall be as follows:

a. For methods under par. (b) 3., 4. and 5., each braced wall panel shall be at least 48 inches in length, covering a minimum of three stud spaces where studs are spaced 16 inches on center and covering a minimum of two stud spaces where studs are spaced 24 inches on center.

b. For the method under par. (b) 6., each braced wall panel and shall be at least 96 inches in length where applied to one face of a braced wall panel and at least 48 inches in length where applied to both faces.

c. For methods under par. (b) 3., 4. and 5., for purposes of computing the percentage of panel bracing required in Table 21.25-H, the effective length of the braced wall panel shall be equal to the actual length of the panel.

d. When the method under par. (b) 6. panels are applied to only one face of a braced wall panel, bracing percentages required in Table 21.25-H under other methods permitted column shall be doubled.

2. 'Exceptions.' a. Lengths of braced wall panels for continuous wood structural panel sheathing shall be in accordance with sub. (9) (c).

b. Lengths of alternate braced wall panels shall be in accordance with sub. (9) (a) or (b).

c. For methods under par. (b) 3., 4. and 5., panels between 36 inches and 48 inches in length shall be permitted to count towards the required percentage of bracing in Table 21.25-H, and the effective contribution shall comply with Table 21.25-G.



**TABLE 21.25-G**  
EFFECTIVE LENGTHS FOR BRACE WALL PANELS LESS THAN 48 INCHES IN ACTUAL LENGTH  
(BRACING METHODS PAR. (b) 3., 4. and 5.)

Actual Length of Braced Wall Panel (inches)	Effective Length of Braced Wall Panel (inches)		
	8-foot Wall Height	9-foot Wall Height	10-foot Wall Height
48	48	48	48
42	36	36	N/A
36	27	N/A	N/A

(d) *Braced Wall Panel Location and Amounts.* Braced wall panels shall begin no more than 12.5 feet from each end of a braced wall line per figures 21.25-A and 21.25-B, and shall be located every 25 feet on center. Bracing amounts shall comply with Table 21.25-H for the bracing materials and methods specified under par. (b).

(c) *Braced Wall Lines.* 1. 'General.' Maximum spacing between parallel wall lines shall be no more than 35 feet.

2. 'Exception.' Spacing between braced wall lines may be increased to 50 feet; however, the percentage of wall bracing on the braced wall lines perpendicular to the spacing, must be increased by multiplying the values in Table 21.25-H by a factor equal to the braced wall line spacing divided by 35 feet, and the

length to width ratio for the floor/roof diaphragm as measured between braced wall lines does not exceed 3:1.

3. 'Offsets.' Offsets in braced wall lines, out-of-plane of up to 4 feet shall be permitted provided that the total out-to-out offset dimension in any braced wall line is not more than 8 feet per Figure 21.25-C.

4. 'Variation from story to story.' Variation in bracing method from story to story is permitted.

5. 'Variation within a story.' Variation in bracing method from braced wall line to braced wall line within a story is permitted, except that the continuous sheathing method with wood structural panels shall conform to the additional requirements of sub. (9) (c).

Note: See Appendix for further explanatory material.

**TABLE 21.25-H**  
MINIMUM REQUIRED BRACING AMOUNTS FOR WALLS

Wall Supporting:	Amount of Bracing Per Wall Line <sup>4, 5</sup> Braced segments shall be located at least every 25'-fr o.c. but not less than the following percentages:	
	Wood Structural Panel Sheathing [Sub. (8) (b) 4. and (9) (b) and (c)]	Other Methods Permitted [Sub. (8) (b) 1., 2., 3., 5. and 6.]
Roof only <sup>1</sup>	16%	16% <sup>2</sup>
Floor and roof	16%	25% <sup>2</sup>
Two floors and roof	25%	35% <sup>3</sup>

<sup>1</sup>The 'Roof only' condition also applies to one braced wall line of wood frame construction on the ground floor where all other exterior walls on the ground floor are constructed of masonry or concrete in accordance with s. Comm. 21.18.

<sup>2</sup>Wood and metal let in bracing exempt from % bracing requirement, but not spacing requirement.

<sup>3</sup>Wood and metal let in bracing not permitted as a bracing method.

<sup>4</sup>Maximum wall heights equal 12 feet. For wall heights over 10 feet, increase percent bracing requirement an additional 20%.

<sup>5</sup>For continuous sheathing method with wood structural panels, percent requirement may be decreased 10% when openings on the wall line do not exceed 85% of wall height and may be decreased 20% when openings do not exceed 67% of wall height. See Table 21.25-K.

**FIGURE 21.25-A**  
BRACED WALL PANELS AND BRACED WALL LINES

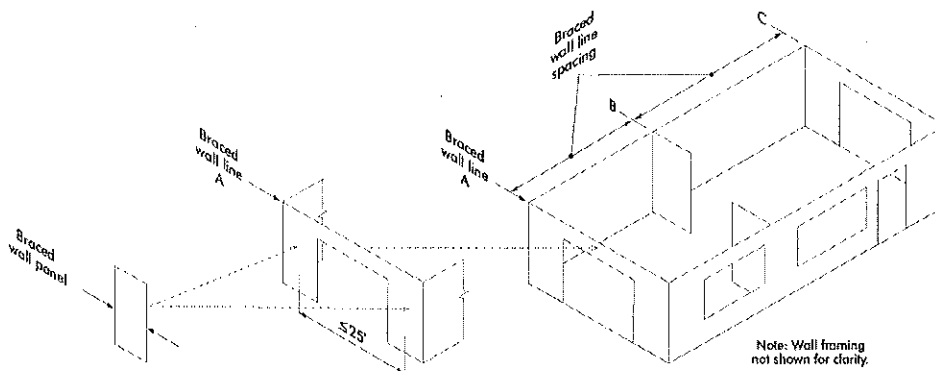

**FIGURE 21.25-B**  
**PERMITTED BRACED WALL PANEL DISTANCES**  
**FROM ENDS OF A BRACED WALL LINE**

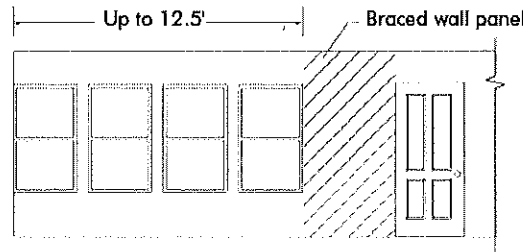

**FIGURE 21.25-C**  
**PERMITTED OFFSETS**

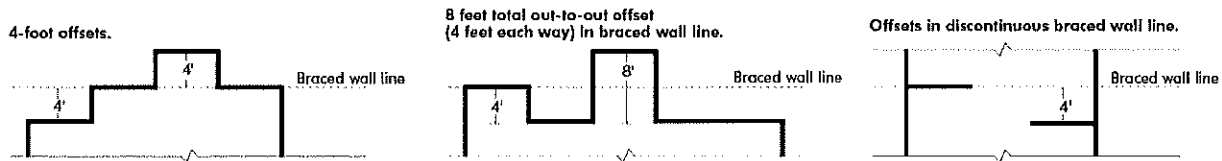

(f) *Angled Corners.* 1. At corners, braced wall lines may angle out of plane up to 45 degrees with a maximum diagonal length of 8 feet.

2. When determining the percentage of bracing, the length of each braced wall line shall be determined as shown in Figure 21.25-D.

3. The placement of bracing for the braced wall lines shall begin at the point where the braced wall line, which contains the

angled wall adjoins the adjacent braced wall line.

Note: This is at Point A as shown in Figure 21.25-D.

4. Where an angled corner is constructed at an angle equal to 45 degrees and the diagonal length is no more than 8 feet in length, the angled wall may be considered as part of either of the adjoining braced wall lines, but not both.

5. Where the diagonal length is greater than 8 feet, it shall be considered its own braced wall line and be braced in accordance with par. (b).

**FIGURE 21.25-D**  
**ANGLED CORNERS**

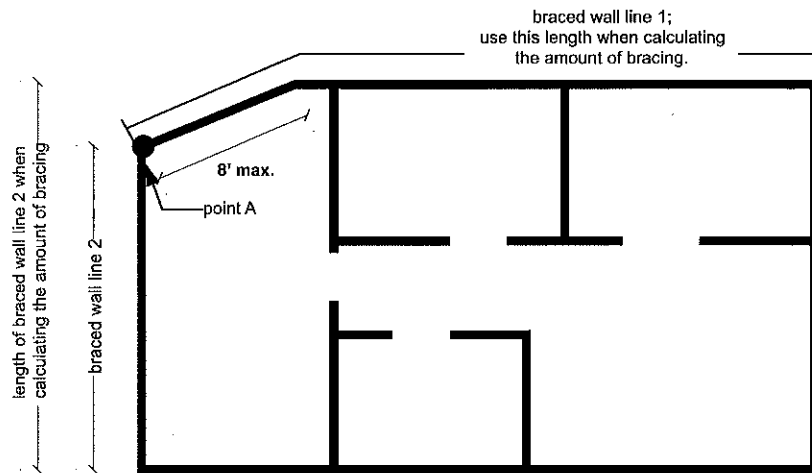

(g) *Braced wall panel support.* Braced wall panels shall be supported on floor framing or foundations as follows:

1. Where joists are perpendicular to braced wall lines above or below, blocking shall be provided between the joists at braced wall panel locations to permit fastening of wall plates in accordance with the fastener table in the appendix.

2. Where joists are parallel to braced wall lines above or below, a rim joist or other parallel framing member shall be provided at the wall to permit fastening of wall plates in accordance with the fastener table in the appendix.

3. Braced wall panels shall be permitted to be supported on cantilevered floor joists meeting the cantilever limits of s. Comm 21.22 (6) provided joists are blocked at the nearest bearing wall

location, except such blocking is not required for cantilevers not exceeding 24 inches where a full height rim joist is provided.

4. Elevated post or pier foundations supporting braced wall panels shall be designed in accordance with accepted engineering practice.

(h) *Panel joints.* 1. 'General.' Except as provided under subd. 2., all vertical joints of panel sheathing shall occur over, and be fastened to common studs. Horizontal joints in braced wall panels shall occur over, and be fastened to common blocking of a minimum 1½ inch thickness.

2. 'Exceptions.' a. Blocking at horizontal joints is not required in wall segments that are not counted as braced wall panels.

b. Where the bracing percentage provided is at least twice the minimum percentage required by Table 21.25-H, blocking at horizontal joints is not required in braced wall panels using methods par. (b) 4., 5. or 6.

(9) ALTERNATIVE BRACING METHODS AND MODIFICATIONS. (a) *General.* As an alternative to the bracing methods under sub. (8), the wall bracing methods in this subsection may also be used.

(b) *Alternate braced wall panels.* 1. 'General.' Alternate braced wall panels constructed in accordance with subd. 2., 3., 4. or 5. may replace each 4 feet of braced wall panel as required under sub. (8) (b). The maximum height and minimum length of each panel shall be in accordance with Table 21.25-I.

2. 'Supporting roof only.' a. In one-story buildings, each panel shall be sheathed on one face with  $\frac{3}{8}$ -inch-minimum-thickness wood structural panel sheathing nailed with 8d common or galvanized box nails in accordance with the fastening table in the appendix and blocked at all wood structural panel sheathing edges.

b. Two anchor bolts installed in accordance with s. Comm 21.18 (1) (c) 3. shall be provided in each panel.

c. Anchor bolts shall be placed 6 to 12 inches from each end of the plate.

d. Each panel end stud shall have a tie-down device fastened to the foundation, capable of providing an uplift capacity in accordance with Table 21.25-I.

e. The tie-down device shall be installed in accordance with the manufacturer's recommendations.

f. The panels shall be supported directly on a foundation or on floor framing supported directly on a foundation, which is continuous across the entire length of the braced wall line.

g. This foundation shall be reinforced with not less than one number 4 bar at the top and bottom.

h. When the continuous foundation is required to have a depth greater than 12 inches a minimum 12-inch-by-12-inch continuous footing or turned down slab edge is permitted at door openings in the braced wall line.

i. This continuous footing or turned down slab edge shall be reinforced with not less than one number 4 bar at the top and bottom.

j. This reinforcement shall be lapped 15 inches with the reinforcement required in the continuous foundation located directly under the braced wall line.

3. 'Supporting floor and roof only.' In the first story of two-story buildings, each braced wall panel shall be in accordance with subd. 2., except that the wood structural panel sheathing edge nailing spacing shall not exceed four inches on center.

TABLE 21.25-I

Sheathed Length	Height of Braced Wall Panel				
	8 ft.	9 ft.	10 ft.	11 ft.	12 ft.
	2'-4"	2'-8"	2'-8"	3'-2"	3'-6"
Sub. (9) (b) 2. Tie-down Force (lbs)	1800	1800	1800	2000	2200
Sub. (9) (b) 3. Tie-down Force (lbs)	3000	3000	3000	3300	3600

4. 'Alternate bracing method with Extended Header over Opening and Tie Downs, supporting a roof only.' a. Each panel shall have a length of not less than 16 inches and a height of not more than 10 feet.

b. Each panel shall be sheathed on one face with a single layer of  $\frac{3}{8}$ -inch-minimum-thickness wood structural panel sheathing nailed with 8d common or galvanized box nails in accordance with Figure 21.25-E.

c. The wood structural panel sheathing shall extend up over the header and shall be nailed in accordance with Figure 21.25-E.

d. Glue laminated beams, LVL's or a built-up header consisting of at least two 2 x 12s fastened in accordance with the fastener table in the appendix may be used.

e. A spacer, if used, shall be placed on the side of the built-up beam opposite the wood structural panel sheathing.

f. The header shall extend between the inside faces of the first full-length outer studs of each panel.

g. The clear span of the header between the inner studs of each panel shall be not less than 6 feet and not more than 18 feet in length.

h. A strap with an uplift capacity of not less than 1,000 pounds shall fasten the header to the side of the inner studs opposite the sheathing.

i. One anchor bolt not less than  $\frac{5}{8}$ -inch-diameter, installed in accordance with s. Comm 21.18 (1) (c) 3. shall be provided in the center of each sill plate.

j. The studs at each end of the panel shall have a tie-down device fastened to the foundation with an uplift capacity of not less than 4,200 pounds.

k. Where a panel is located on one side of the opening, the header shall extend between the inside face of the first full-length stud of the panel and the bearing studs at the other end of the opening.

L. The bearing studs shall also have a tie-down device fastened to the foundation with an uplift capacity of not less than 1,000 pounds.

m. The tie-down devices shall be an embedded-strap type, installed in accordance with the manufacturer's recommendations.

n. The panels shall be supported directly on a foundation, which is continuous across the entire length of the braced wall line.

o. The foundation shall be reinforced with not less than one number 4 bar top and bottom.

p. Where the continuous foundation is required to have a depth greater than 12 inches, a minimum 12-inch-by-12-inch continuous footing or turned down slab edge is permitted at door openings in the braced wall line.

q. This continuous footing or turned down slab edge shall be reinforced with not less than one number 4 bar top and bottom.

r. This reinforcement shall be lapped not less than 15 inches with the reinforcement required in the continuous foundation located directly under the braced wall line.

5. 'Alternate bracing method with Extended Header Over Opening and Tie Downs, in a wall supporting a floor and roof only.' Each wall panel shall be braced in accordance with subd. 4., except that each panel shall have a length of at least 24 inches.

**Figure 21.25-E**  
ALTERNATE BRACING METHOD WITH EXTENDED HEADER AND TIE DOWNS

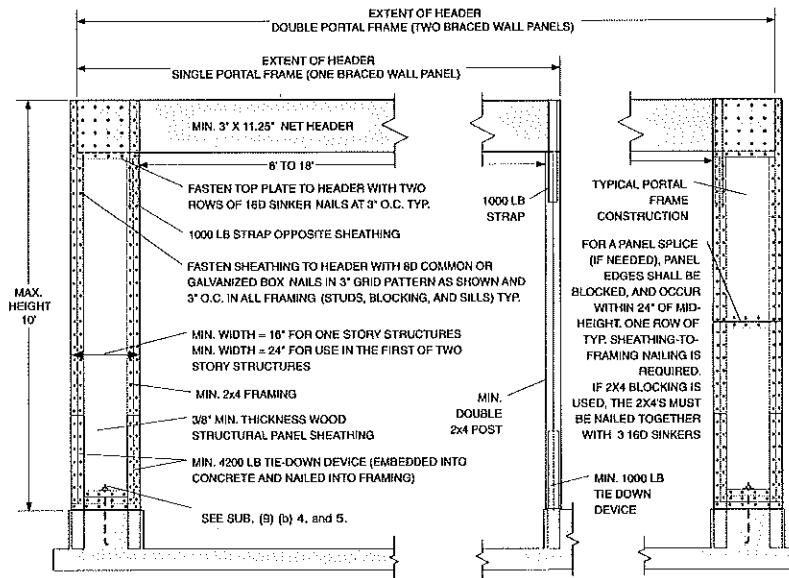

- (c) *Continuously sheathed braced wall line using wood structural panels.* 1. 'General.' a. Continuously sheathed braced wall lines using wood structural panels shall comply with this section.
- b. Different bracing methods are not permitted within a continuously sheathed braced wall line.
- c. Other bracing methods prescribed by this code are permitted on other braced wall lines on the same story level or on different story levels of the building.
- 2. 'Continuously-sheathed braced wall line requirements.' Continuously-sheathed braced wall lines shall be constructed in accordance with Figure 21.25-F and shall comply with all of the following requirements:

- a. Structural sheathing shall be applied to all exterior sheathable surfaces of a braced wall line including areas above and below openings.
- b. Only full-height braced wall panels shall be used for calculating the braced wall percentage in accordance with Table 21.25-H.
- c. Exterior corner framing shall be constructed and fastened in accordance with details in Figure 21.25-G.
- d. Figures 21.25-H, 21.25-I and 21.25-J provide alternative construction options to Figure 21.25-F, when 2 foot wide wood structural panels are not available at the corners of continuous sheathed wall lines and the return wall lines.

**FIGURE 21.25-F**  
CONTINUOUSLY-SHEATHED BRACED WALL LINE

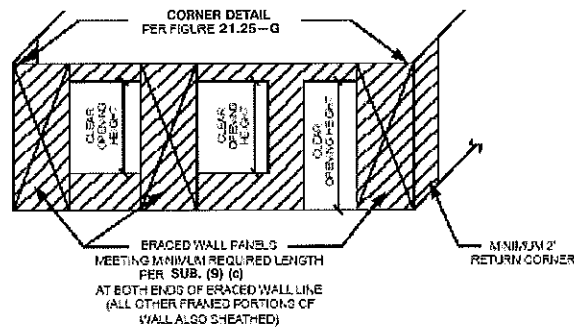

3. 'Braced wall panel length.' In a continuously-sheathed wood structural panel braced wall line, the minimum braced wall

panel length shall be permitted to be in accordance with Table 21.25-J.

**TABLE 21.25-J**  
LENGTH REQUIREMENTS FOR BRACED WALL PANELS IN A CONTINUOUSLY SHEATHED WALL<sup>1</sup>

Minimum Length of Braced Wall Panel (Inches)			Maximum Opening Clear Height Next to the Braced Wall Panel (% of wall height)	Braced Wall Panel Height to Width Ratio
8-foot wall	9-foot wall	10-foot wall		
48	54	60	100%	2:1
32	36	40	85%	3:1
24	27	30	67%	4:1 <sup>2</sup>

<sup>1</sup>Interpolation is permitted.

<sup>2</sup>For a garage supporting a roof only, a 4:1 aspect ratio is permitted for full-height sheathed wall segments on either side of the garage openings.

**FIGURE 21.25-G**  
**TYPICAL EXTERIOR CORNER FRAMING FOR CONTINUOUS STRUCTURAL PANEL SHEATHING**  
**SHOWING REQUIRED STUD-TO-STUD NAILING**

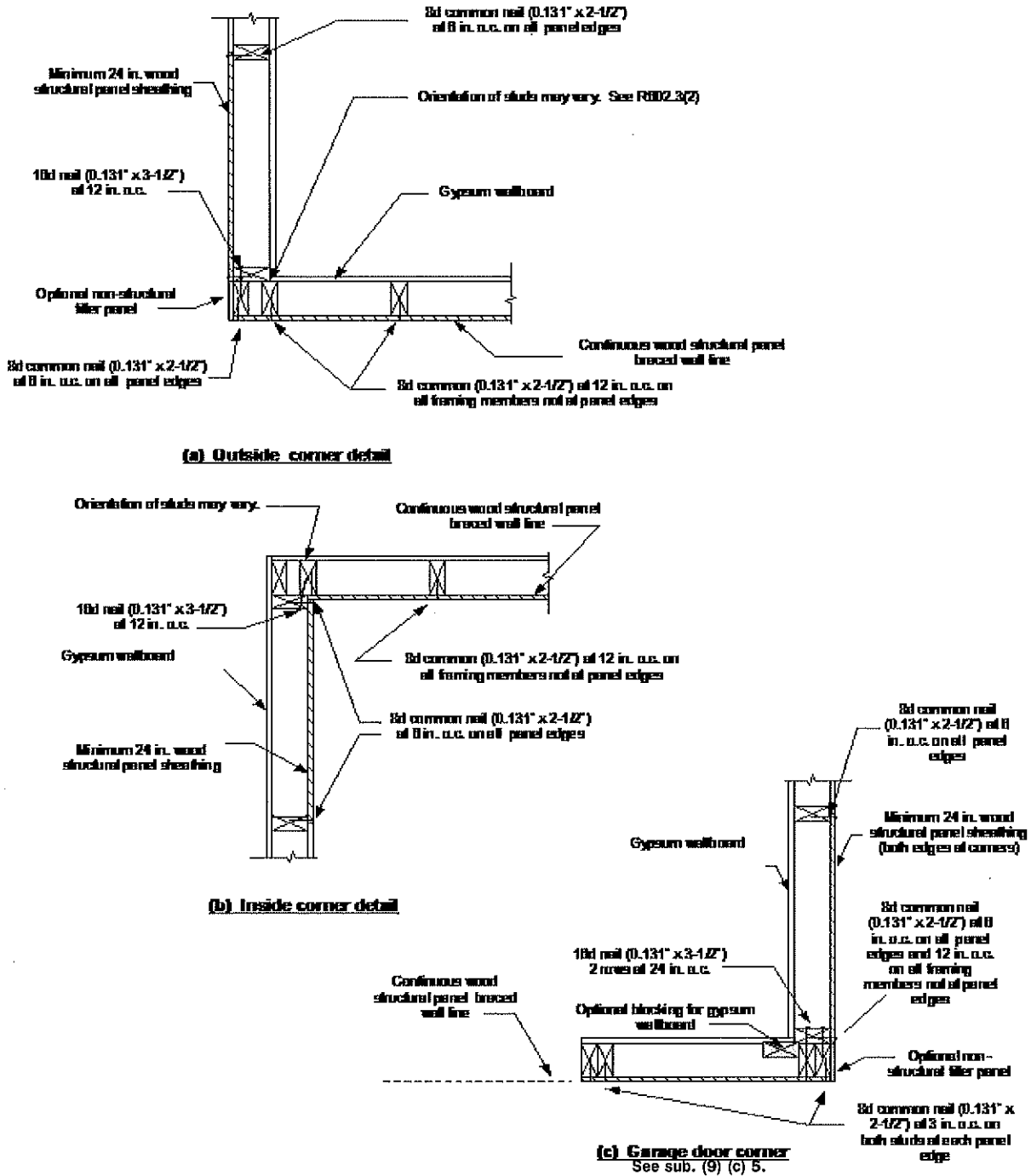

**Figure 21.25-H**  
CONTINUOUSLY-SHEATHED BRACED WALL LINE WITHOUT CORNER RETURN

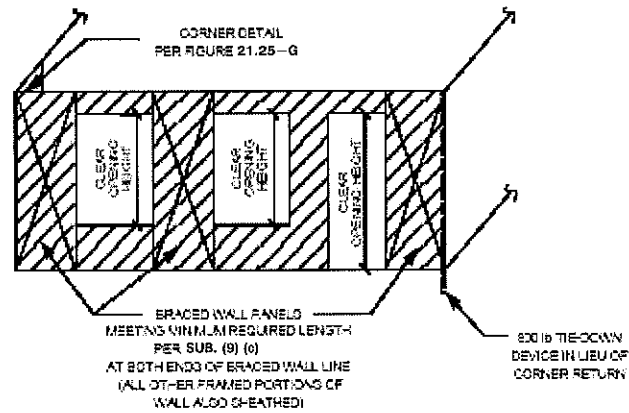

**FIGURE 21.25-I**  
CONTINUOUSLY SHEATHED BRACED WALL LINE — FIRST BRACED WALL PANEL AWAY FROM END OF WALL LINE WITHOUT TIE DOWN

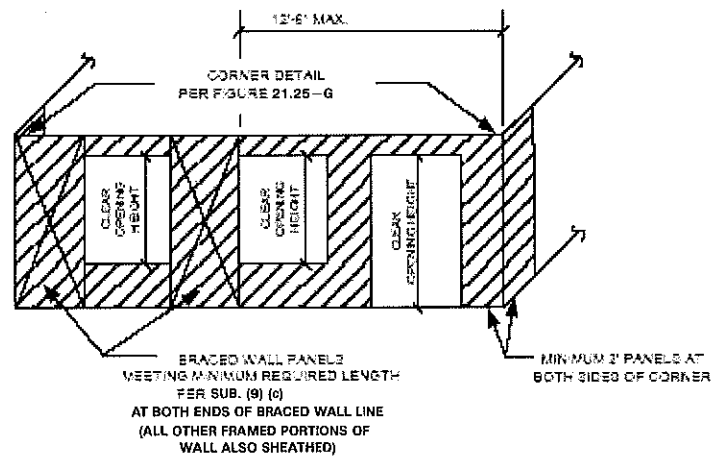

**FIGURE 21.25-J**  
CONTINUOUSLY SHEATHED BRACED WALL LINE — FIRST BRACED WALL PANEL AWAY FROM END OF WALL LINE WITH TIE DOWN

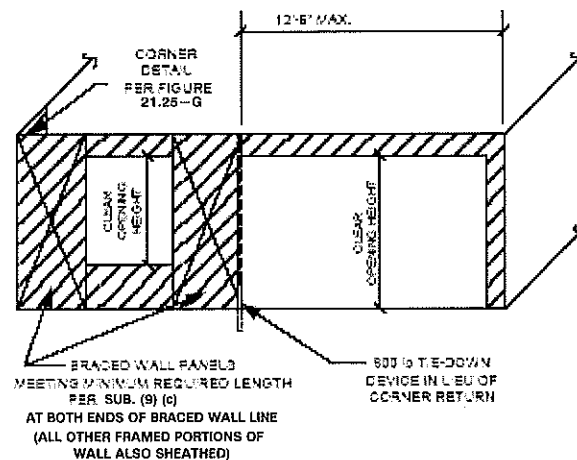

4. 'Braced wall percentage.' In addition to bracing percentage adjustments specified elsewhere in this code, the braced wall percentages for methods under sub. (8) (b) 4. from Table 21.25-H

shall be permitted to be multiplied by a factor in accordance with Table 21.25-K.

**TABLE 21.25-K**  
**ADJUSTMENT FACTORS TO THE PERCENTAGE OF REQUIRED BRACING PER WALL LINE — CONTINUOUSLY SHEATHED**

Adjustment Based on Maximum Wall Clear Opening Height:		Multiply Percentage of Bracing Per Wall Line By:
Continuous wood structural panel sheathing when maximum opening height in wall line does not exceed*	85% of wall height	0.9
	67% of wall height	0.8

\*Percentage of bracing for continuous wood structural panel sheathing shall be based on sub. (8) (b) 4. requirements.

5. '6:1 aspect ratio continuous structural panel sheathing with extended header.' a. Wall segments having a maximum 6:1 height to width ratio are permitted only when built in accordance with Figure 21.25-K.

b. The maximum 6:1 height-to-width ratio is based on height being measured from the top of the header to the bottom of the wall segment bottom-plate.

c. For purposes of calculating the percentage of panel bracing required by Table 21.25-H, the length of the braced wall panel shall be the measured length of the full height sheathing segment adjacent to the opening.

d. Corners at the ends of walls using this option shall be constructed in accordance with Figure 21.25-G. Where 6:1 ratio segments are used at the ends of braced wall lines, a 2 foot minimum width wood structural panel must be installed on the corner return as shown in Figure 21.25-F. An 800 lb tie down may be installed in lieu of a 2 foot corner return, as shown in Figure 21.25-H.

e. The reduction factors for continuously braced walls from subd. 4. shall be applied when calculating applicable percentages of wall bracing.

f. The number of wall segments having a maximum 6:1 height to width ratio in a wall line may not exceed 4.

g. For purposes of resisting wind pressures acting perpendicular to the wall, the minimum requirements of Figure 21.25-K are sufficient for wind speeds less than 110 mph in exposure category B.

h. For exposure categories C and D, the header to jack stud strap requirements and the number of additional jack studs shall be in accordance with Table 21.25-L.

Note: See Table 21.25-L footnotes for definitions of the exposure categories.

i. 6:1 aspect ratio segments with extended header are permitted over raised wood floors or second story applications, when constructed in accordance with rim board/band joist connection in Figure 21.25-K (b) or (c).

FIGURE 21.25-K  
6:1 ASPECT RATIO BRACED WALL PANELS USING CONTINUOUS WOOD STRUCTURAL PANEL SHEATHING AND EXTENDED HEADERS

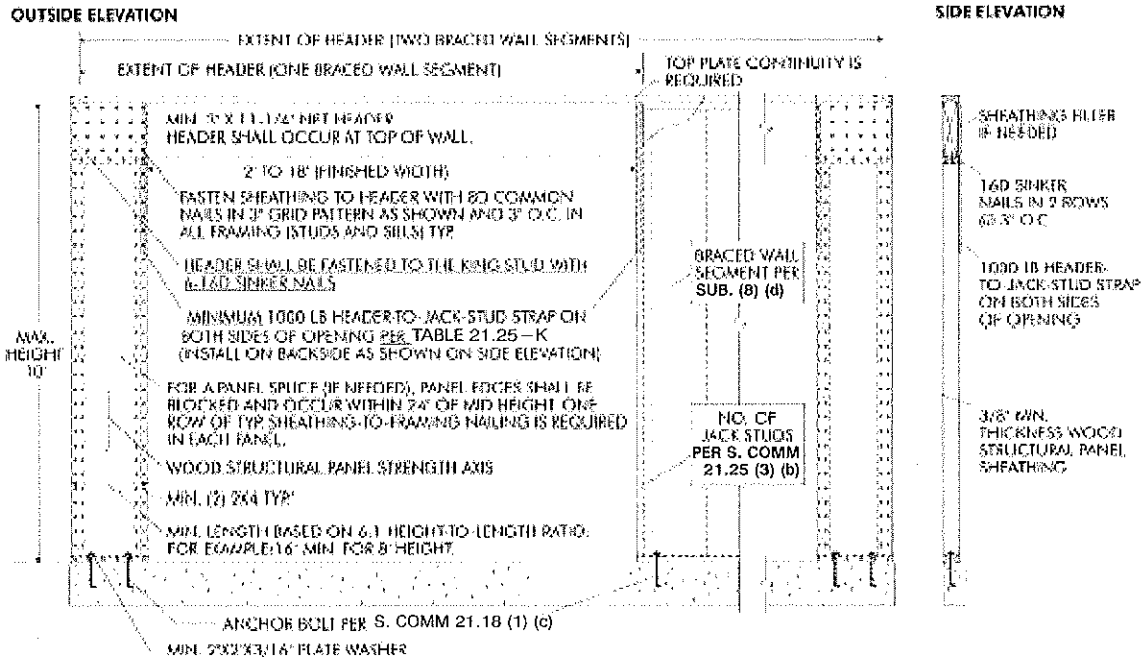

FOR WIND EXPOSURE CATEGORIES C AND D, ADDITIONAL JACK STUDS MAY BE REQUIRED PER TABLE 21.25-L

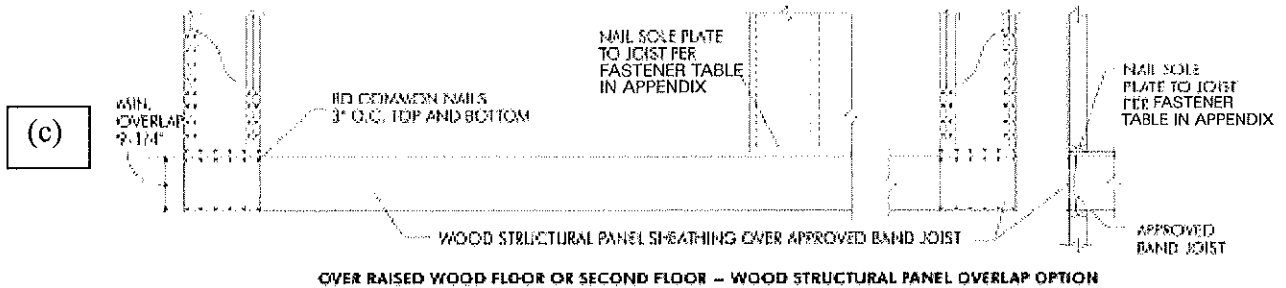
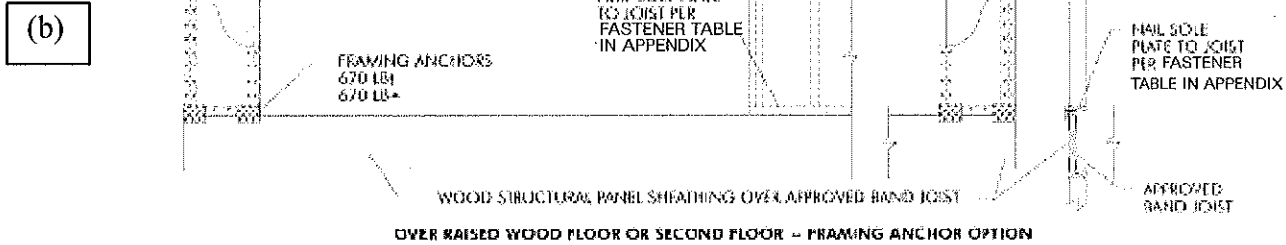

NOT TO SCALE



TABLE 21.25-L

HEADER TO JACK STUD STRAP AND THE NUMBER OF ADDITIONAL JACK STUDS REQUIRED FOR RESISTING WIND PRESSURES PERPENDICULAR TO 6:1 ASPECT RATIO WALLS LOCATED IN WIND EXPOSURE CATEGORIES C AND D<sup>c</sup>

Required Strap Capacity (lb) <sup>a</sup>	Wall Height (ft)	Wind Exposure Category C			Wind Exposure Category D		
		85 mph	90 mph	less than 110 mph	85 mph	90 mph	less than 110 mph
	10 and less	1000	1200	2275	1375	1750	3050
Number of additional 2x4 Jack Studs <sup>b</sup>	8	—	—	—	—	—	1
	9	—	—	1	—	1	2
	10	—	1	2	1	2	3

<sup>a</sup> If 2x6 framing is used, then the required strap capacity may be multiplied by 0.65, but in no case shall the required strap capacity be less than 1,000 lb.

<sup>b</sup> If 2x6 framing is used, then no additional framing shall be required.

<sup>c</sup> Exposure category B is comprised of urban and suburban areas, wooded areas, or other terrain with numerous closely-spaced obstructions having the size of single-family dwellings or larger. Exposure B shall be assumed unless the site meets the definition of another type exposure.

Exposure category C is comprised of flat open country and grasslands with scattered obstructions, including surface undulations or other irregularities, having heights generally less than 30 feet extending more than 1,500 feet from the building site in any quadrant. This exposure also applies to any building located within Exposure B type terrain where the building is directly adjacent to open areas of Exposure C type terrain in any quadrant for a distance of more than 600 feet.

Exposure category D is comprised of flat, unobstructed areas exposed to wind flowing over open water for a distance of at least 1 mile. This exposure applies only to those buildings and other structures exposed to the wind coming from over the water. Exposure D extends inland from the shoreline a distance of 1,500 feet or 10 times the height of the building or structure, whichever is greater.

**History:** Cr Register, November, 1979, No. 287, eff. 6-1-80; cr. (1) (d) and am. (3) (b), Register, February, 1985, No. 350, eff. 3-1-85; r. and recr. (3) (b), am. Table 21.25 B and E, Register, January, 1989, No. 397, eff. 2-1-89; am. (3) (a) and (6), Register, March, 1992, No. 435, eff. 4-1-92; r. and recr. (1) (c), am. Table 21.25-D, cr. Table 21.25-F, Register, November, 1995, No. 479, eff. 12-1-95; am. Table 21.25-A, Register, January, 1999, No. 517, eff. 2-1-99; r. (1) (b) and (c), renum. (1) (d) to be (b), r. and recr. (2), (6) and Tables 21.25-E and F, and am. (3) (b) 3., Register, March, 2001, No. 543, eff. 4-1-01; CR 02-077: r. (3) (c) Register May 2003 No. 569, eff. 8-1-03; CR 08-043: am. (1) (title), r. (1) (b), renum. (1) (a) and (6) (a) 4. to be (1) and (6) (a) 5., r. and recr. Table 21.25-A, cr. (6) (a) 4., (7), (8) and (9) Register March 2009 No. 639, eff. 4-1-09; correction in Figure 21.25-E made under s. 13.92 (4) (b) 7., Stats., Register March 2009 No. 639; CR 09-104: am. 21.25 (8) (e) 2., Table 21.25-H, (9) (b) 3., Table 21.25-J, Figure 21.25-G (c), (9) (c) 4. Register December 2010 No. 660, eff. 1-1-11.

**Comm 21.26 Masonry walls.** Masonry walls shall be constructed in accordance with the requirements of this section.

(1) **COLD WEATHER WORK.** When ambient air temperature is below 40°F, the cold weather construction procedures under ACI 530.1 shall be followed.

**Note:** The requirements for cold weather work are in sections 1.8 and 1.8C of the 2005 edition of the ACI standard.

(2) **MASONRY UNITS.** (a) *Unused concrete units.* Previously unused concrete masonry units shall conform to the ASTM C 90 standard.

(b) *Unused clay or shale units.* Previously unused clay or shale masonry units shall conform to the appropriate ASTM standard: C 62; C 216; or C 652. Units which will be exposed to weathering or frost action shall be Grade SW as specified in these standards.

(c) *Used masonry units.* All previously used masonry units shall be free from physical defects which interfere with the installation or impair the structural properties of the unit.

(3) **TYPES OF MORTAR.** (a) *Mortar specifications.* The type of mortar shall be determined from Table 21.26-A. The mortar shall conform to the requirements of ASTM C-270.

(b) *Surface bond mortars.* Surface bond mortars for masonry walls shall be mixed in accordance with the proportions specified on the bag.

(4) **MORTAR COMPONENTS.** Mortar components shall comply with the following requirements:

(a) *Water.* Water shall be clean and free of deleterious amounts of acids, alkalis, or organic materials.

(b) *Admixtures or mortar colors.* Admixtures or mortar colors shall not be added to the mortar unless the resulting mortar conforms to the mortar specifications. Only mineral oxide may be used as mortar color and shall not exceed 10% by weight of the cement.

(c) *Mixing.* Mortar shall be mixed for at least 3 minutes after all ingredients have been added with the maximum amount of water to produce a workable consistency. Mortars that have stiffened due to water evaporation shall be retempered by adding water as frequently as needed to restore the required consistency.

Mortars shall be used and placed in final position within 2½ hours after mixing.

**Note:** To ensure proper mortar mixing, machine mixing is recommended.

TABLE 21.26-A

TYPES OF MORTAR FOR VARIOUS KINDS OF MASONRY

Kind of Masonry	Types of Mortar
Foundations:	
Footings .....	M, S
Walls of solid units .....	M, S, N
Walls of hollow units .....	M, S
Hollow walls .....	M, S
Masonry other than foundation masonry:	
Piers of solid masonry .....	M, S, N
Piers of hollow units .....	M, S
Walls of solid masonry .....	M, S, N, O
Walls of solid masonry not less than 12 in. thick or more than 35 ft. in height, supported laterally at intervals not exceeding 12 times the wall thickness .....	M, S, N, O
Walls of hollow units; load-bearing or exterior, and hollow walls 12 in. or more in thickness .....	M, S, N
Hollow walls, less than 12 in. thick .....	M, S, N
Linings of existing masonry, either above or below grade ..	M, S
Masonry other than above .....	M, S, N

(d) *Cementitious material.* Cementitious material shall conform to the standards approved by the department.

**Note:** The department will accept cementitious material conforming to the following standards: ASTM C91, Masonry Cement; ASTM C150, Portland Cement; ASTM C595, Portland Blast-Furnace Slag Cement; ASTM C207, Hydrated Lime for Masonry Purposes; and ASTM C5, Quick Lime for Structural Purposes.

(e) *Aggregates.* Aggregates for use in masonry mortar shall consist of natural sand or manufactured sand and shall be graded.

**Note:** The department will accept aggregates in accordance with ASTM C144.

(5) **CAVITY WALL.** (a) *Corbels.* Corbels shall be constructed in accordance with ACI 530.

(b) *Projections.* The projection of a wall beyond the edge of a supporting member other than masonry, such as a shelf angle or edge of a beam, shall not exceed 1¼ inches, unless at least 2/3 the mass of the wythe of masonry involved is located directly over the load-carrying member.

(6) **OPENINGS AND LINTELS.** (a) *Openings.* The masonry above openings shall be supported. The bearing length of structural elements which support the masonry above the opening shall be not less than 4 inches.

(b) *Lintels.* Unless designed through structural analysis, lintels shall be provided using either steel angles or reinforcing bars in accordance with Table 21.26-C.

**TABLE 21.26-C**  
**ALLOWABLE SPANS FOR LINTELS SUPPORTING**  
**MASONRY VENEER**

Size of Steel Angle <sup>1,3</sup>	No Story Above	One Story Above	Two Stories Above	No. of 1/2" or Equivalent Reinforcing Bars <sup>2</sup>
L 3 x 3 x 1/4	6'-0"	3'-6"	3'-0"	1
L 4 x 3 x 1/4	8'-0"	5'-0"	3'-0"	1
L 6 x 3 1/2 x 1/4	14'-0"	8'-0"	3'-6"	2
2-L 6 x 3 1/4 x 1/4	20'-0"	11'-0"	5'-0"	4

<sup>1</sup>Long leg of the angle shall be placed in a vertical position.

<sup>2</sup>Depth of reinforced lintels shall be not less than 8 inches and all cells of hollow masonry lintels shall be grouted solid. Reinforcing bars shall extend not less than 8 inches into the support.

<sup>3</sup>Steel members indicated are adequate typical examples; other steel members meeting structural design requirements may be used.

**(7) MASONRY VENEERS.** (a) *Veneer over frame construction.*  
1. Masonry veneers may be corbeled over the foundation wall, but the corbeling shall not exceed one inch.

2. A minimum one-inch air space shall be provided between the veneer and the sheathing unless a manufactured offset material is used.

3. Where no brick ledge is formed in the foundation wall, corrosion resistant metal or other water-resistant flashing shall extend over the top of the foundation wall from the outside face of the wall and shall extend at least 6 inches up on the sheathing. The flashing shall be installed to drain any water outward.

4. Weep holes shall be provided at the bottom masonry course at maximum intervals of 2 feet.

5. Ventilation openings shall be provided at the top of the wall.

Note: The ventilation opening could be other than a weep hole.

6. Studs and sheathing behind masonry veneer shall be covered with material used to construct the water-resistive barrier as required under s. Comm 21.24 (4).

Note: Acceptable water-resistive barrier materials include polymeric-based house wraps and #15 or greater asphalt-saturated felts that comply with ASTM D 226 for type I felt.

7. Masonry or brick veneer shall be above final exterior grade unless there is through-wall flashing at grade or within 2 courses above grade.

(b) *Veneer over masonry back-up.* Corrosion-resistant metal or other water-resistant base flashing shall be provided at the bottom of the veneer and shall extend over the top of the foundation and up at least 6 inches and be embedded in the back-up course. The flashing shall be installed to drain any water outward. Weep holes shall be provided at maximum intervals of 3 feet.

(c) *Veneer attachment.* Veneers shall be anchored or adhered in accordance with ACI 530 and ACI 530.1.

**(8) FLASHING.** (a) *General.* 1. Flashing shall be installed in accordance with this section to drain any water outward away from structural members, sheathing and insulation.

2. Open joints or weep holes shall be provided in the facing immediately above the flashing at a horizontal spacing not exceeding 2 feet.

3. Flashing that will be exposed to ultraviolet light shall consist of materials which are durable and permanently UV-resistant, such as sheet metal or heavy-gauge PVC.

Note: Materials including house wrap, asphalt-impregnated building paper, plastic sheeting, peel-and-stick rubberized sheet material, and light-gauge PVC are not acceptable as meeting this requirement.

(b) *Location.* 1. 'Lintels and chimneys.' In exterior hollow masonry walls, flashing shall be installed at the backsides of chimneys and at the bottom of the cavity formed by openings such as lintels over doors and windows.

2. 'Veneer.' Flashing shall be installed at the bottom of veneer and shall extend over the top of the foundation and up at least 8 inches and be embedded in the backing course.

(c) *Weep holes.* 1. Weep holes may not be placed below final grade.

2. Rope or similar material used to form a weep hole shall be removed as soon as the mortar sets.

3. Weep holes shall be 3/8-inch minimum diameter.

**(9) BEARING.** (a) *Concentrated loads.* Beams, girders, trusses, joists and other members producing concentrated loads shall bear a minimum of 3 inches on one of the following:

1. 'Concrete beam.' The equivalent of a nominally reinforced 2,500 psi concrete beam 8 inches in height.

2. 'Solid masonry.' At least 8 inches in height of masonry composed of solid masonry units with all voids and joints completely filled with mortar.

3. 'Metal plate.' A metal plate of sufficient thickness and size to distribute the load to masonry units. For piers and columns, the bearing plate shall not exceed 60% of the cross-sectional area of the pier or column and the resultant reaction of all vertical and horizontal loads shall fall within the middle third of the member.

4. 'Bond beam.' The bond beam shall be the equivalent of not less than an 8-inch lintel (bond beam) block with 2 No. 4 bars embedded in high strength mortar fill or equivalent. The loads shall bear on the fill.

(b) *Continuous loads.* Joists, trusses and beams other than wood, spaced 4 feet or less on center and 40 feet or less in length, slabs or other members causing continuous loads shall be transmitted to masonry with a minimum bearing of 3 inches upon solid masonry at least 2 1/2 inches in height, or as indicated for concentrated loads.

(c) *Stack bond walls.* Concentrated loads shall be distributed into masonry laid in stack bond by a concrete beam or bond beam [as defined in par. (a)]. For masonry of solid units, 2 additional rows of a continuous tie assembly may be used instead of a concrete beam or bond beam.

(d) *Support of wood floor members.* Where a wood structural member is buried in masonry for support, it shall be firecut or a self-releasing device shall be used. Where the end of a wood structural member is built into an exterior wall, a 1/2-inch air space shall be provided at the sides, top and end of such member.

**(10) BONDING.** Unless designed through structural analysis, all masonry walls shall be bonded as follows:

(a) *Single-wythe walls.* Masonry units in single-wythe walls shall be lapped at least 2 inches or one-third the height of the masonry unit, whichever is greater, or through the use of continuous tie assemblies spaced at 16-inch vertical intervals.

(b) *Multi-wythe walls.* Adjacent wythes shall be bonded with continuous tie assemblies spaced at vertical intervals not exceeding 16 inches; or individual ties of at least 3/16-inch diameter for each 4 1/2 square feet of wall area, spaced at a maximum vertical distance of 18 inches and a maximum horizontal distance of 36 inches; or bonded with a full course of masonry headers every seventh course. The clear distance between bond courses shall not exceed 16 inches for solid masonry units and 24 inches for hollow masonry units. Hollow walls shall not be bonded with headers.

(11) **BOLTS AND ANCHORS.** The allowable shear on steel bolts and anchors shall not exceed the values given in Table 21.26.

**TABLE 21.26**  
ALLOWABLE SHEAR ON BOLTS AND ANCHORS

Bolt or Anchor Diameter (inches)	Embedment <sup>1</sup> (inches)	Allowable Shear (pounds)
1/4	4	270
3/8	4	410
1/2	4	550
5/8	4	750
3/4	5	1100
7/8	6	1500
1	7	1850
1 1/8	8	2250

<sup>1</sup>Bolts and anchors shall be solidly embedded in mortar or grout.

(12) **JOINTS.** Joints in masonry construction shall be constructed in accordance with ACI 530.1.

(13) **CLEANING.** Chemical cleaning agents shall be prevented from harming the metal reinforcement of structural components and shall not be of a strength which will adversely affect the mortar.

**History:** Cr. Register, November, 1979, No. 287, eff. 6-1-80; am. (3) and cr. Table 21.26-B1 Register, February, 1985, No. 350, eff. 3-1-85; am. (9) (b), Register, January, 1989, No. 397, eff. 2-1-89; am. (6) (b), Register, March, 1992, No. 435, eff. 4-1-92; r. and recr. (2), am. (5) (c), (7) (a) 3., 4., (b), r. (14), Register, November, 1995, No. 479, eff. 12-1-95; CR 02-077; am. (7) (a) 4. Register May 2003 No. 569, eff. 8-1-03; CR 08-043: r. and recr. (1), (5) (a), (8) and (12), renum. (3) (intro.) and (a) to be (3) (a) and (b) and am. (3) (a), am. (4) (b) and (7) (a) 2., r. (5) (c), Tables 21.26-B and B1, cr. (7) (a) 5. to 7. and (c) Register March 2009 No. 639, eff. 4-1-09; CR 09-104: am. (8) (a) 3. Register December 2010 No. 660, eff. 1-1-11.

## Subchapter VIII — Roof and Ceilings

**Comm 21.27 Roof design and framing.** (1) **STRUCTURAL DESIGN.** (a) *General.* Roof and roof-ceiling assemblies shall support all dead loads plus the minimum live loads under par. (c) and s. Comm 21.02.

(b) *Applicability of tables.* The joist and rafter tables in the appendix are valid for roofs with a minimum slope of 3 in 12. Lesser slopes require engineering analysis or shall be provided with a ridge beam.

(c) *Sloped roof snow loads.* Snow loads specified in s. Comm 21.02 (1) (b) 2. may be reduced for roof slopes greater than 30° by multiplying the snow load by Cs. The value of Cs shall be determined by the following:

$$C_s = 1 - \frac{(a - 30)}{40}$$

where a is the slope of the roof expressed in degrees.

**Note:** A roof pitch of 7 in 12 is equal to 30°.

(2) **LATERAL RESTRAINT OF WALLS.** Provisions shall be taken to absorb the horizontal thrust produced by a sloping roof through the use of wall ties, ceiling joists, beams at the ridge or at the wall or a system designed through structural analysis.

(3) **UPLIFT AND SUCTION FORCES.** (a) *General.* 1. Roofs shall withstand a pressure of at least 20 pounds per square foot acting upward normal to the roof surface.

2. Roof overhangs, eaves, canopies and cornices shall withstand an upward wind pressure of at least 20 pounds per square foot applied to the entire exposed area.

(b) *Anchorage.* 1. Roof framing members spanning more than 6 feet measured from the outermost edge of the roof shall be permanently fastened to the top plate of load bearing walls using engineered clips, straps or hangers.

2. Roof framing members spanning 6 feet or less measured from the outermost edge of the roof shall be permanently fastened to the top plate of load bearing walls using toe-nailing or engineered clips, straps or hangers.

**Note:** For information on toe nailing, see the fastener schedule table in the Appendix.

(4) **ROOF RAFTERS.** (a) *General.* 1. Rafters shall be notched to fit the exterior wall plate and fastened to the wall.

2. Collar ties shall be installed on the upper third of every third pair of abutting roof rafters or every 48 inches, whichever is less.

**Note:** Collar ties are intended to provide stability to the roof at the ridge. Lateral restraint for the walls must be provided in accordance with sub. (2).

(b) *Ridge boards.* 1. Where rafters meet to form a ridge, the rafters shall be attached to a ridge board.

2. The ridge board shall have a depth at least equal to the length of the cut end of the rafter abutting it.

3. Where all rafters are placed directly opposite each other or are offset at the ridge board by less than the thickness of the rafter, the ridge board shall have a nominal thickness of at least 1 inch.

4. Where one or more rafters are offset at the ridge board by more than the thickness of the rafter, the ridge board shall have a nominal thickness of at least 2 inches.

(c) *Ridge beams.* Rafters shall be attached to ridge beams using engineered clips, straps or hangers or the connection shall be designed through structural analysis.

(d) *Bearing.* The required bearing for wood rafters shall be in accordance with the NDS adopted in Table 20.24-2, except in no case shall the bearing be less than 1 1/2 inches on wood or metal or less than 3 inches on masonry or concrete.

(e) *Ladders.* 1. Overhangs at gable end walls of more than 12 inches shall be provided with ladders which extend into the structure a distance no less than the length of the overhang.

2. The ladders shall be fastened to the wall.

3. The interior end of each ladder shall be attached to a rafter or truss with a hanger.

**Note:** For the purposes of this section, a ladder is defined as a perpendicular projection extending beyond the face of the wall below.

(5) **CEILING JOISTS.** (a) Ceiling joists shall be nailed to exterior walls and to the ends of rafters.

(b) Ends of ceiling joists shall be lapped at least 3 inches and be fastened either with 3-16d nails or in accordance with the floor joist requirements under s. Comm 21.22 (4) (a) 1. d.

**Note:** See the fastener table in the Appendix for a nailing schedule for ceiling joists.

(c) Where ceiling joists are placed at right angles to the rafters, the lookout joist or ties shall be fastened to the parallel ceiling joists or rafters using engineered clips, straps or hangers or the connection shall be designed through structural analysis.

(6) **VALLEY AND HIP RAFTERS.** (a) *Valley rafters.* 1. Where no bearing is provided under valley rafters at the intersection of 2 roof areas, the valley rafters shall be doubled in thickness and shall be at least 2 inches deeper than the required common rafter to permit full bearing at the beveled end.

2. Where ridges are provided at different elevations, vertical support shall be provided for the interior end of the lower ridge board or ridge beam.

(b) *Hip rafters.* Where no bearing is provided under hip rafters, the hip rafters shall be of the same thickness as common rafters and shall be at least 2 inches deeper than required to permit full contact with the jack rafter.

(7) **ROOF TRUSSES.** (a) Metal plate connected wood roof trusses shall be designed in accordance with TPI 1 and the NDS adopted under s. Comm 20.24.

(b) Truss members shall not be cut, bored or notched, except as allowed under sub. (8) (d).

(c) If connection is provided to stabilize a non-load bearing wall, a slotted expansion joint or clip shall be used.

(8) **NOTCHING AND BORING.** (a) *General.* 1. Notching and boring of beams or girders is prohibited unless determined through structural analysis.

2. Notching and boring of ceiling joists and rafters shall comply with pars. (b) and (c).

(b) *Notching*. 1. Notches located in the top or bottom of ceiling joists and rafters are prohibited from all of the following:

- a. Having a depth exceeding  $\frac{1}{6}$  the depth of the member.
- b. Having a length exceeding  $\frac{1}{3}$  the depth of the member.
- c. Being located in the middle  $\frac{1}{3}$  of the span of the member.

2. Where ceiling joists or rafters are notched at the ends, the notch may not exceed  $\frac{1}{4}$  the depth of the member.

3. Bird mouth cuts may not exceed  $\frac{1}{3}$  the depth of the rafter unless the seat cut bears fully on the wall plate.

(c) *Boring*. 1. Holes bored within 2 inches of the top or bottom of ceiling joists or rafters may not be located in the middle  $\frac{1}{3}$  of the span of the member.

2. The diameter of a hole may not exceed  $\frac{1}{3}$  the depth of the member.

3. A hole may not be bored within 2 inches of a notch or another hole.

4. The distance between adjacent holes may not be less than the diameter of the larger hole.

(d) *Engineered wood products*. Notching or boring of engineered wood products shall be done in accordance with the manufacturer's instructions provided those instructions were developed through structural analysis or product testing.

(9) **ROOF SHEATHING, BOARDS AND PLANKING.** (a) *Structural sheathing*. The allowable loads and spans for structural sheathing shall be in accordance with the grade stamp on the panel.

(b) *Roof boards*. 1. Where the rafter spacing is 24 inches on center or less, roof boards may be used that have a minimum thickness of  $\frac{5}{8}$ -inch for solid sheathing and  $\frac{3}{4}$ -inch for spaced sheathing.

2. Where the rafter spacing is greater than 24 inches on center, roof boards shall be tongue and groove, at least 1.5 inches thick.

(c) *Roof planks*. 1. Roof planks shall be tongue and groove or splined and at least 2 inches, nominal, in thickness.

2. Planks shall terminate over beams unless the joints are end matched.

3. The planks shall be laid so that no continuous line of joints will occur except at points of support.

4. Planks shall be nailed or fastened to each beam.

**History:** Cr. Register, November, 1979, No. 287, eff. 6-1-80; am (3) (a), Register, January, 1989, No. 397, eff. 2-1-89; r. and recr. (1), am. (3) (a), Register, March, 1992, No. 435, eff. 4-1-92; r. and recr. (3) (a), Register, November, 1995, No. 479, eff. 12-1-95; r. and recr. (3) (a) 1. and 2. c., Register, January, 1999, No. 517, eff. 2-1-99; am. (3) (a) 1. a., Register, March, 2001, No. 543, eff. 4-1-01; CR 02-077: r. and recr. (3) (b) Register May 2003 No. 569, eff. 8-1-03; CR 08-043: r. and recr. Register March 2009 No. 639, eff. 4-1-09.

**Comm 21.28 Weather protection for roofs. (1) GENERAL.** (a) All roofs shall be designed and constructed to assure drainage of water.

(b) All fasteners shall be corrosion resistant.

(2) **UNDERLAYMENT FOR SHINGLES.** Underlayment consisting of number 15 asphalt-impregnated felt paper or equivalent or other type I material that shows no water transmission when tested in accordance with ASTM D 226 or ASTM D 4869 shall be provided under shingles.

**Note:** Underlayment materials meeting the requirements of ASTM D 1970 meet the performance requirements of this section.

(3) **ASPHALT SHINGLES.** (a) *General*. 1. Shingles that have a self-sealing adhesive strip shall include a sealant which has an average bond strength of at least 1.5 pounds per 3.75 inches of shingle width, at 32°F.

**Note:** The department will accept results of testing conducted in accordance with an approved test method for verifying compliance with the sealant uplift resistance required in this paragraph. Information on the applicable test method may be obtained from the department.

2. Each shingle package shall be labeled by the manufacturer to indicate conformance to the applicable ASTM standard for each type of shingle or the exception in par. (c).

3. Shingles shall be installed in accordance with the manufacturer's recommendations.

4. Shingles shall have at least 4 fasteners per strip shingle or 2 fasteners per interlocking shingle, unless the manufacturer has other specifications.

5. Shingle head lap shall be at least 2 inches, unless the manufacturer has other specifications.

**Note:** See s. Comm 20.07 (62) for definitions of shingle terms.

**Note:** The Residential Asphalt Roofing Manual can be purchased from the Asphalt Roofing Manufacturers Association at 6000 Executive Boulevard, Suite 201, Rockville, Maryland 20852-3803. This manual contains extensive information on shingles from manufacture through installation, inspection and maintenance. It includes a recommendation that properly driven and applied nails are the preferred fastening system for asphalt shingles.

**Note:** Section Comm 20.04 (2) requires compliance with all parts of this code, including these roofing provisions, for an alteration to any dwelling that is regulated under this code.

(b) *Organic shingles*. Organic asphalt shingles shall conform to ASTM D 225 and the Class C requirements of ASTM E 108, and shall pass the wind resistance test of ASTM D 3161.

(c) *Fiberglass shingles*. Fiberglass asphalt shingles shall conform to ASTM D 3462 except that laminated shingles shall have a tear strength of at least 1450 grams in each ply.

(4) **ICE DAM PROTECTION.** (a) Shingled or shake roofs that extend over a heated area of a dwelling or attached garage and that have a slope of 4:12 or less shall be provided with ice dam protection in the form of sheet metal or a product labeled as meeting the requirements of ASTM D 1970.

(b) The ice dam protection shall extend at least 30 inches up the roof slope from the roof edge and at least 12 inches up the roof slope beyond the inner face of the exterior wall.

(5) **OTHER ROOF COVERINGS.** All roof coverings not otherwise addressed in this section shall be installed in accordance with the manufacturer's instructions or a national standard recognized by the department.

(6) **REROOFING.** New roof coverings may not be installed over existing roof coverings where any of the following conditions exist:

(a) The existing roof or roof covering is water-soaked or has deteriorated such that it is inadequate as a base for additional roofing.

(b) The existing roof is wood shake, slate, clay, cement or asbestos-cement tile.

(c) The existing roof has 2 or more applications of any type of permanent roof covering.

(7) **FLASHING.** (a) *General*. Flashing shall be installed at the junction of chimneys and roofs, in all valleys, and around all roof openings.

(b) *Flashing of open valleys*. 1. Open valleys shall be flashed with at least No. 28 gauge corrosion-resistant sheet metal, 16 inches wide, or a layer of at least 50-pound roll roofing, 16 inches wide, placed over a layer of number 15 roofing underlayment.

2. Flashing sections shall be overlapped by at least 4 inches.

(c) *Flashing of closed valleys*. Where shingles are laced or woven over the valley, the valley shall be flashed with at least one layer of 50-pound roofing, at least 20 inches wide, over a layer of number 15 roofing underlayment.

(d) *Chimney flashing*. 1. Chimneys shall be flashed and counter-flashed to a height of at least 6 inches.

2. Chimney crickets or saddles shall be installed where the upper side of a chimney is more than 30 inches wide on a sloping roof.

3. The intersection of the cricket and the chimney shall be flashed and counter-flashed to a height of at least 6 inches.

**History:** Cr. Register, November, 1979, No. 287, eff. 6-1-80; am. (7) (a), r. and recr. Table 21.28-A, Register, January, 1989, No. 397, eff. 2-1-89; am. (1), (5) and

(6), cr. (2m) and (6) (a) 3., r. and recr. (4) (c), Register, March, 1992, No. 435, eff. 4-1-92; cr. (6) (c), Register, November, 1995, No. 479, eff. 12-1-95; CR 02-077: r. and recr. (1) (a), renum. (6) (intro) to (c) to be (6) (a) to (d) and am. (6) (a) to (c) Register May 2003 No. 569, eff. 8-1-03; CR 08-043: r. and recr. Register March 2009 No. 639, eff. 4-1-09.

### Subchapter IX — Fireplace Requirements

**Comm 21.29 Masonry fireplaces.** Masonry fireplaces shall be constructed of masonry, stone or concrete. Masonry fireplaces shall be supported on foundations of concrete or masonry. Structural walls shall be at least 8 inches thick. Masonry fireplaces shall conform to the following requirements:

(1) **FLUE SIZE.** The fireplace flue size shall be based on the type of flue and the fireplace opening indicated in Table 21.29.

TABLE 21.29

MINIMUM FLUE SIZE FOR MASONRY FIREPLACES

Type of Flue	Minimum Cross-Sectional Area
Round	$\frac{1}{12}$ of fireplace opening but not less than 75 square inches.
Square or rectangular	$\frac{1}{10}$ of fireplace opening but not less than 75 square inches.

(2) **TERMINATION OF CHIMNEY.** Masonry fireplace chimneys shall extend at least 3 feet above the highest point where the chimney passes through the roof and at least 2 feet higher than any portion of the dwelling within 10 feet of the chimney.

(3) **FIREBOX MATERIALS.** The firebox shall be of the preformed metal type, at least  $\frac{1}{4}$ -inch thick, or listed by a nationally recognized laboratory; or shall be lined with firebrick, at least 2 inches thick and laid in thin joints of refractory cement. The back and sidewalls of the firebox, including the lining, shall be at least 8 inches nominally thick masonry, at least 4 inches of which shall be solid.

(4) **LINTEL.** Masonry over the fireplace opening shall be supported by a lintel of steel or masonry.

(5) **DUCTS.** Warm-air circulating ducts shall be constructed of masonry or metal.

(5m) **RETURN AIR GRILLES.** Return air grilles shall not be located in bathrooms, kitchens, garages, utility spaces or in a confined space defined under s. Comm 23.06 in which a draft diverter or draft regulator is located.

(6) **HEARTH EXTENSION.** (a) Masonry fireplaces shall have a hearth extension made of noncombustible material.

(b) The structural support for the hearth and hearth extension shall be a minimum of 4 inches of reinforced concrete.

(c) There shall be no structural framing material within 1 inch of the hearth or hearth extension in any direction. Any wooden forms or supports used during construction shall be removed.

(d) The minimum dimensions of the hearth extension shall be in accordance with Table 21.29-1.

TABLE 21.29-1

HEARTH EXTENSION DIMENSIONS

Fireplace Opening (Sq. Ft.)	Extension from Fireplace Opening (inches)	
	Side	Front
Less than 6	8	16
6 or Greater	12	20

(7) **DAMPERS.** Dampers shall be made of cast iron or at least No. 12 gauge sheet metal. The area of the damper opening shall be at least 90% of the required flue area when in the open position.

(8) **HOODS.** Metal hoods, used in lieu of a masonry smoke chamber, shall be constructed of at least No. 19 gauge corrosion-resistant metal with all seams and connections of smokeproof construction. The hood shall be sloped at an angle of 45° or less from the vertical and shall extend horizontally at least 6 inches beyond the firebox limits. Metal hoods shall be kept a minimum of 18 inches from the combustible materials unless approved for reduced clearances.

Note: The department will accept dampers and hoods listed by nationally recognized laboratories.

(9) **FLUE LINERS.** (a) Flue liners shall be installed in accordance with s. Comm 21.30 (7) and this section.

(b) Flue liners shall start at the top of the fireplace throat and extend to a point at least 4 inches above the top of the chimney cap.

(c) Firebrick may be used in the throat of the fireplace as an inlet to the flue liner.

(10) **CLEANOUT OPENINGS.** Fireplaces with ash dumps shall be provided with cleanout openings at the base. Doors and frames of the opening shall be made of ferrous materials.

(11) **MANTEL SHELVES AND COMBUSTIBLE TRIM.** Woodwork or other combustible materials shall not be placed within 6 inches of the fireplace opening. Combustible materials located within 12 inches of the fireplace opening shall not project perpendicularly more than  $\frac{1}{8}$ -inch for each inch distance from the opening.

(12) **FRAMING AROUND FIREPLACES.** Combustible materials located near fireplaces shall be installed in accordance with s. Comm 21.30 (9).

(13) **CORBELING.** Unless designed through structural analysis, masonry chimneys shall not be corbeled from a wall more than 6 inches nor shall a masonry chimney be corbeled from a wall less than 12 inches in nominal thickness unless it projects equally on each side of the wall. The corbeling shall not exceed one-inch projection for each brick course.

History: Cr. Register, November, 1979, No. 287, eff. 6-1-80; am. Register, February, 1985, No. 350, eff. 3-1-85; am. (6) and Table 21.29-1, Register, January, 1989, No. 397, eff. 2-1-89; am. (intro.) and (12), cr. (5m), r. and recr. (6), Register, March, 1992, No. 435, eff. 4-1-92; r. (12) and renum. (13) and (14) to be (12) and (13), Register, January, 1999, No. 517, eff. 2-1-99; r. and recr. (6) and (9), Register, March, 2001, No. 543, eff. 4-1-01.

**Comm 21.30 Masonry chimneys.** Masonry chimneys shall conform to the following provisions:

(1) **MATERIALS.** No masonry chimney shall rest upon wood. The foundation shall be designed and built in conformity with the requirements for foundations. Masonry chimney walls shall be at least 4 inches in nominal thickness. Hollow cored masonry units may be used to meet the 4 inch nominal thickness requirement.

(2) **FLUE SIZE.** Chimney flues for appliances shall be at least equal in area to that of the area of the connector from the appliance.

(3) **MULTIPLE FLUE SEPARATION.** When more than one flue is contained in the same chimney, a masonry separation of at least 4 inches nominal in thickness shall be provided between the individual flues. The joints of adjacent flue linings shall be staggered by at least 7 inches.

(4) **CORBELING.** Unless designed through structural analysis, masonry chimneys shall not be corbeled from a wall more than 6 inches nor shall a masonry chimney be corbeled from a wall less than 12 inches in nominal thickness unless it projects equally on each side of the wall. The corbeling shall not exceed one-inch projection for each brick course.

(5) **INLETS.** Inlets to masonry chimneys shall enter the side and be provided with thimbles. Thimbles shall be at least No. 24 manufacturer's standard gauge (0.024 inch) or  $\frac{5}{8}$ -inch thick, refractory material. Each chimney shall have an inlet installed at the time of construction.

(6) **CLEAN-OUT OPENING.** Every masonry chimney shall be provided with a clean-out opening at the base. Such openings shall be equipped with metal doors and frames arranged to remain closed when not in use. Clean-out openings shall be located below the lowest inlet to the flue.

(7) **FLUE LINERS.** (a) Masonry chimneys shall be lined with a material that will resist corrosion, softening and cracking at temperatures up to 1800°F, such as vitrified clay sewer pipe or minimum  $\frac{5}{8}$ -inch thick fireclay lining material.

(b) All flue liners shall be laid in a full bed of refractory mortar or refractory cement.

(c) Variations in inside and outside dimensions shall not exceed ¼ inch for clay flue liners.

(d) There shall be a minimum clearance of ½-inch and a maximum clearance of 1-inch between the flue liner and the chimney walls.

(e) Unless serving a masonry fireplace under s. Comm 21.29, flue liners shall commence at the chimney footing.

**(8) CHIMNEY CAPS.** Chimneys shall be provided with precast or cast-in-place concrete chimney caps. Chimney caps shall have a minimum thickness of 2 inches, shall slope outwards away from the flue, and shall provide a one-inch overhang and drip edge on all sides. A slip joint shall be installed between the flue and the cap. The slip joint shall be filled with ¼-inch felt or similar material and shall be caulked with high-temperature caulk or similar material to prevent water infiltration.

**(9) CLEARANCE TO COMBUSTIBLES.** (a) The minimum clearance between combustibles and masonry chimneys which have any portion located within the exterior wall of the dwelling shall be 2 inches. The minimum clearance between combustibles and masonry chimneys which have all parts completely outside the dwelling, exclusive of soffit or cornice areas, shall be one inch.

(b) Except as required under pars. (c) and (d), the clearance spaces shall remain completely open.

(c) The clearance spaces between chimneys and wood joists, beams, headers or other structural members shall be fireblocked at each floor level from chimney footing all the way to the roof flashing with galvanized steel, at least 26 gage thick or with non-combustible sheet material.

(d) Noncombustible material shall be used to prevent entry of debris into the clearance spaces.

**History:** Cr. Register, February, 1985, No. 350, eff. 3-1-85; am. (8), Register, March, 1992, No. 435, eff. 4-1-92; r. and rec. (8) and (9); Register, November, 1995, No. 479, eff. 12-1-95; r. and rec. (7) (a), cr. (7) (d) and (e), and am. (9) (c), Register, March, 2001, No. 543, eff. 4-1-01; CR 02-077: am. (7) (b) and (d) Register May 2003 No. 569, eff. 8-1-03.

**Comm 21.32 Factory-built fireplaces.** Factory-built fireplaces consisting of a fire chamber assembly, one or more chimney sections, a roof assembly and other parts shall be tested and listed by a nationally recognized testing laboratory.

**(1) FIREPLACE ASSEMBLY AND MAINTENANCE.** The fireplace assembly shall be erected and maintained in accordance with the conditions of the listing.

(a) All joints between the wall or decorative facing material and the fireplace unit shall be completely sealed, firestopped or draft-stopped with a noncombustible caulk or equivalent.

(b) Doors installed on factory built fireplaces shall conform with the terms of the listing and the manufacturers installation instructions for the fireplace unit.

**(2) DISTANCE FROM COMBUSTIBLES.** Portions of the manufactured chimney extending through combustible floors or roof/ceiling assemblies shall be installed in accordance with the distances listed on the chimney in order to prevent contact with combustible materials.

**(3) HEARTH EXTENSIONS.** Hearth extensions shall be provided in accordance with the manufacturer's listing. Where no hearth extension is specified in the listing, a hearth extension shall be provided in accordance with s. Comm 21.29 (6).

**History:** Cr. Register, November, 1979, No. 287, eff. 6-1-80; renum. from Ind 21.30 and r. and rec. (3), Register, February, 1985, No. 350, eff. 3-1-85; cr. (1) (a) and (b), am. (3) and Table 21.32-1, Register, January, 1989, No. 397, eff. 2-1-89; r. and rec. Register, March, 1992, No. 435, eff. 4-1-92.

## Subchapter X — Construction in Floodplains

**Comm 21.33 Construction in floodplains. (1) GENERAL.** Where dwelling construction is allowed by local zoning ordinances to take place in floodfringe areas of floodplains, the dwelling shall meet the requirements of this subchapter.

**Note:** The department of natural resources (DNR) and the federal emergency management agency (FEMA) also have regulations that apply to construction in floodfringe areas.

**(2) ELEVATION.** (a) *General.* Except as provided in pars. (b) and (c), all dwellings constructed within a floodfringe area shall be elevated so the lowest floor and all basement floor surfaces are located at or above the base flood elevation.

(b) *Certified floodproof basements.* Floodproof basements may have the top of the basement floor no more than 5 feet below the base flood elevation provided the basement is designed by a registered architect or engineer to be watertight and impermeable. No limitation is placed on the use or occupancy of a certified floodproof basement by the provisions of this subchapter.

(c) *Other enclosed spaces.* 1. Enclosed spaces not meeting the requirements of par. (b) are allowed at any depth below the base flood elevation provided the spaces are used only for one or more of the following purposes:

- Means of egress.
- Entrance foyers.
- Stairways.
- Incidental storage of portable or mobile items.

2. Fully enclosed spaces used only for those purposes listed in subd. 1. shall be designed to automatically equalize the hydrostatic pressure on exterior walls by allowing the entry and exit of floodwaters. Designs for meeting this requirement shall be certified by a registered architect or engineer or shall meet all of the following requirements:

a. There shall be at least 2 pressure relieving openings and the openings shall have a total net area of not less than one square inch for every square foot of enclosed area subject to flooding.

b. The bottom of all openings shall be no more than 12 inches above grade.

c. Openings may not be equipped with screens, louvers, valves or other coverings or devices unless such devices permit the automatic entry and discharge of floodwaters.

**(3) CERTIFICATION OF ELEVATION.** A registered land surveyor, architect or engineer shall certify the actual elevation in relation to mean sea level of the lowest structural member required to be elevated by the provisions of this subchapter.

**(4) ANCHORAGE.** The structural systems of all dwellings shall be designed, connected and anchored to resist flotation, collapse or permanent lateral movement due to structural loads and stresses at the base flood elevation.

**(5) PROTECTION OF ELECTRICAL AND MECHANICAL SYSTEMS.** Electrical and mechanical equipment shall be placed above the base flood elevation or shall be designed to prevent water contact with the equipment in case of a flood up to the base flood elevation.

**(6) CONSTRUCTION MATERIALS AND METHODS.** All dwellings constructed in floodplains shall be constructed using materials and methods designed to minimize flood and water damage.

**History:** Emerg. cr. eff. 5-8-96; cr. Register, February, 1997, No. 494, eff. 3-1-97.

## Comm 21.34 Construction in coastal floodplains.

**(1) GENERAL.** All dwellings constructed in coastal floodplains shall be designed by a registered architect or engineer and shall meet the requirements of this section and s. Comm 21.33.

**(2) ELEVATION.** All dwellings constructed in a coastal floodplain shall be elevated so the lowest portion of all structural members supporting the lowest floor, with the exception of mat or raft foundations, pilings, piling caps, columns, grade beams and bracing, is located at or above the base flood elevation.

**(3) ENCLOSURES BELOW BASE FLOOD ELEVATION.** Enclosures below the base flood elevation in a coastal floodplain may not be used for human occupancy and shall be free of all obstructions, except for non-loadbearing walls and partitions. Non-loadbearing walls and partitions below base flood elevation shall be con-

structed to break away without causing any structural damage to the elevated portion of the dwelling or foundation system due to the effect of wind loads and water loads acting simultaneously.

(4) **FOUNDATIONS.** All dwellings located in a coastal floodplain shall be supported and anchored on pilings or columns. The piling or column shall have adequate soil penetration to resist combined water and wind loads at the base flood elevation. Piling or column design shall consider the effect of scour of soil strata. Mat or raft foundations to support columns may not be used where soil under the mat or raft is subject to scour or other erosion from wave flow conditions.

**History:** Emerg. cr. eff. 5-8-96; cr. Register, February, 1997, No. 494, eff. 3-1-97.

### Subchapter XI — Installation of Manufactured Homes

**Comm 21.40 Installation standards.** (1) (a) The installation of a manufactured home produced on or after April 1, 2007 shall comply with procedures acceptable to the department.

(b) Acceptable installation procedures shall address all of the following:

1. Soil mechanics.
2. Site preparation.
3. Structural support, stabilization and anchorage.
4. Setting.
5. Ventilation of crawl spaces.
6. Connections, plumbing, electrical, HVAC.
7. Joining of home sections.

**Note:** Acceptable installation practices can be found through the Safety and Buildings Division's website at [www.commerce.state.wi.us/SB](http://www.commerce.state.wi.us/SB) or by contacting the Safety and Buildings Division at (608) 264-9596.

**Note:** The design and construction of basements and perimeter foundations to support manufactured homes is addressed under subchapter V.

(2) (a) Except as provided in par. (b), the installation of a manufactured home produced before April 1, 2007 shall be installed in conformance with the requirements in effect at the time the manufactured home was produced.

(b) The installation of a manufactured home produced before April 1, 2007 to be installed on piers shall conform to at least all of the following requirements:

1. No footing may be placed upon unprepared fill material, topsoil, alluvial soil or mud. All organic matter shall be removed from the area that will be beneath any footing.
2. The soil bearing capacity shall be determined through test by a pocket penetrometer or other means of analysis. If the soil bearing capacity under each intended pier location is less than 2000 pounds per square foot, piers shall be located in accordance with the manufacturer's instructions.
3. The home site shall be graded to permit water to drain from under the home and away from the home for a minimum of 5 feet from the home.
4. Every pier shall be supported by a footing. Each footing shall be no less than a nominal 16 inches by 16 inches.
5. Each footing shall consist of one of the following:
  - a. One nominal 4-inch by 16-inch by 16-inch solid concrete block or 2 nominal 4-inch by 8-inch by 16-inch solid concrete blocks. If a single block pier and 2 footing blocks are used, the 2 footing blocks shall be positioned with the joint parallel to the main frame. If a double block pier and 2 footing blocks are used, the 2 footing blocks shall be positioned with the joint either parallel or perpendicular to the main frame.

b. A 16-inch by 16-inch pad constructed of acrylonitrile-butadiene-styrene (ABS) having a rated load bearing capacity of not less than 6000 pounds.

c. An 18-inch diameter hole bored to below the frost line or to unfractured bedrock and filled with poured concrete.

d. Any other materials and systems approved in advance by the department.

6. Piers shall be constructed of concrete blocks, manufactured steel stands or manufactured concrete stands. Manufactured stands shall be labeled for use as piers for manufactured homes.

7. Piers constructed of single stacked concrete blocks shall be limited to a height of 36 inches. Piers constructed of concrete blocks and exceeding 36 inches but less than 80 inches shall be constructed using double stacked blocks with each layer opposing the direction of the layer underneath it. Piers constructed of concrete blocks and exceeding 80 inches shall be constructed using double blocks laid in concrete mortar with each layer opposing the direction of the layer underneath it and with each core filled with concrete and a ½-inch steel reinforcing rod.

8. All concrete blocks shall be 2-core design, construction grade blocks having nominal dimensions of at least 8 inches by 8 inches by 16 inches. All concrete blocks shall be placed with the cores open vertically. The concrete block nearest the main frame of the manufactured home shall be perpendicular to the linear direction of the frame. No concrete block may contact the main frame of the home.

9. Alternative materials may be used for pier installations provided they are approved in advance by the department.

10. Piers shall be placed under the main frame of the chassis at intervals of not more than 7 feet on-center and no more than 3 feet from the exterior side of each end wall. The 7-foot spacing requirement may be varied as permitted by footing, spacing and soil capacity tables provided by the home manufacturer.

11. Piers shall be placed under the bearing points of clear-span openings of 4 feet or more in center mating walls.

12. Piers shall be plumb and centered under the contact area at the point of support.

13. a. Each pier shall be capped with a solid concrete block at least 4 inches thick or a solid wood block having a nominal thickness of at least 2 inches.

b. The cap shall be the same width and length as the top of the pier.

c. The cap shall consist of no more than 2 pieces.

d. Two-piece caps shall be positioned with the joint perpendicular to the main frame.

14. Where shims are utilized, wood shims shall be installed between the pier cap and the frame. Shims shall be driven from opposing sides and shall be no less than 4 inches by 8 inches.

15. Wood caps and shims shall be at least equal to No. 2 spruce pine fir having a minimum fiber bending stress rating of 1200 psi. All wood caps shall be the same species of wood, and all shims shall be the same species of wood.

16. The combination of a nominal 2-inch solid concrete block or a nominal 2-inch wood cap plus shims shall not exceed 3 ½ inches.

17. A minimum clearance of 12 inches shall be maintained beneath the lowest point of the main frame in the area of any utility connection. A minimum clearance of 12 inches shall also be maintained under the home for at least 75% of the home. The remainder of the home may be less than 12 inches above the ground but may not touch the ground.

**History:** CR 05-113; cr. Register December 2006 No. 612, eff. 4-1-07; CR 08-043; am. (2) (b) 13. Register March 2009 No. 639, eff. 4-1-09.

